

CYPRESS RUN TRACT 13
 A PORTION OF TRACT "K" OF CYPRESS RUN - UNIT II
 AS RECORDED IN PLAT BOOK 87, PAGE 65 OF
 THE PUBLIC RECORDS OF PINELLAS COUNTY, FLORIDA
 LOCATED IN SECTION 9 TOWNSHIP 27 SOUTH, RANGE 16 EAST
 PINELLAS, FLORIDA

- LEGEND**
- PROPERTY LINE
 - - - EASEMENT LINE
 - FEMA FLOOD ZONE
 - 100 YEAR FLOODWAY LINE

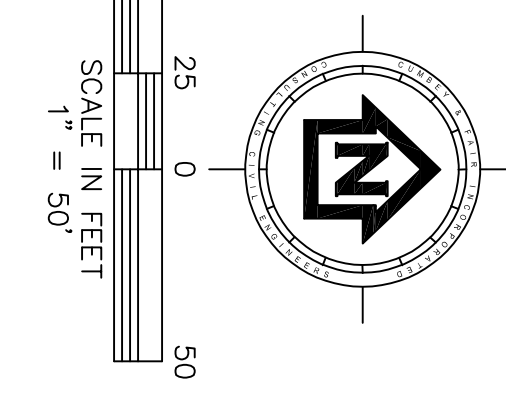

RPD Site Size	Existing	Proposed
RPD Site- 328.35 ac	RPD Site- 328.35 ac	Existing RPD Site- 328.35 ac + Railroad Parcel- 5.461 ac - Warren Parcel- 0.047 ac Revised RPD Site- 333.764 ac
Parcel Sizes	Tract 13- 4.208 ac Railroad Parcel- 5.461 ac Warren Parcel- 0.047 ac	Tract 13- 4.151 ac Railroad Parcel- 5.461 ac Warren Parcel- 0.047 ac
FUO Plan Category (No Change Requested)	Tract 13- RR Railroad Parcel- RR Warren Parcel- RR	Railroad Parcel- RR Warren Parcel- RR
Zoning District	Tract 13- RPD Railroad Parcel- RA Warren Parcel- RPD	Tract 13- RPD (no change) Railroad Parcel- RPD Warren Parcel- RA
Land Uses	Tract 13- Maintenance Facility for Golf Course Railroad Parcel- abandoned RR Warren Parcel- part of Maintenance Facility	Tract 13- 3 Single Family Detached or Attached Homes Maintenance Facility Indoor Recreational Facilities Self Storage Railroad Parcel- Maintenance Facility Indoor Recreational Facilities Self Storage Warren Parcel- 1 Single Family Detached Home 167 units
Maximum RPD Development Potential	164 units	167 units
RPD Density	0.49 u/ac	0.5 u/ac
Flood Zone	Tract 13- X, AE Railroad Parcel- X, AE & A Warren Parcel- X	Tract 13- X, AE Railroad Parcel- X, AE & A Warren Parcel- X
Lot Size	N.A.	N.A.
Lot Dimensions	N.A.	N.A.
Subsides- Principal Structure	NA	NA
Subsides- Accessory Structures	NA	NA
Height	NA	35' for all Buildings
Other Notes		Attached Homes: Front: 10' (From Private Street) Side: 15' between Buildings Rear: 15' Maintenance, Indoor Recreational Facilities & Self Storage Buildings: 10' from all Property Lines

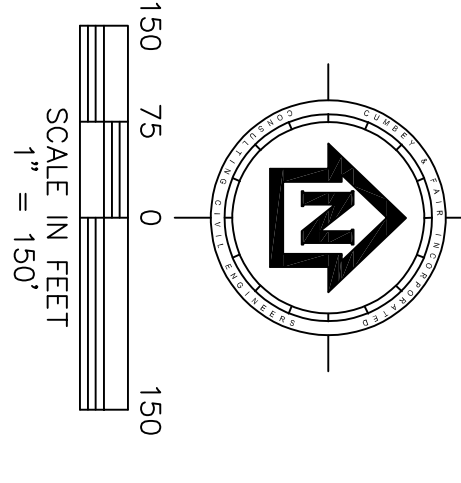
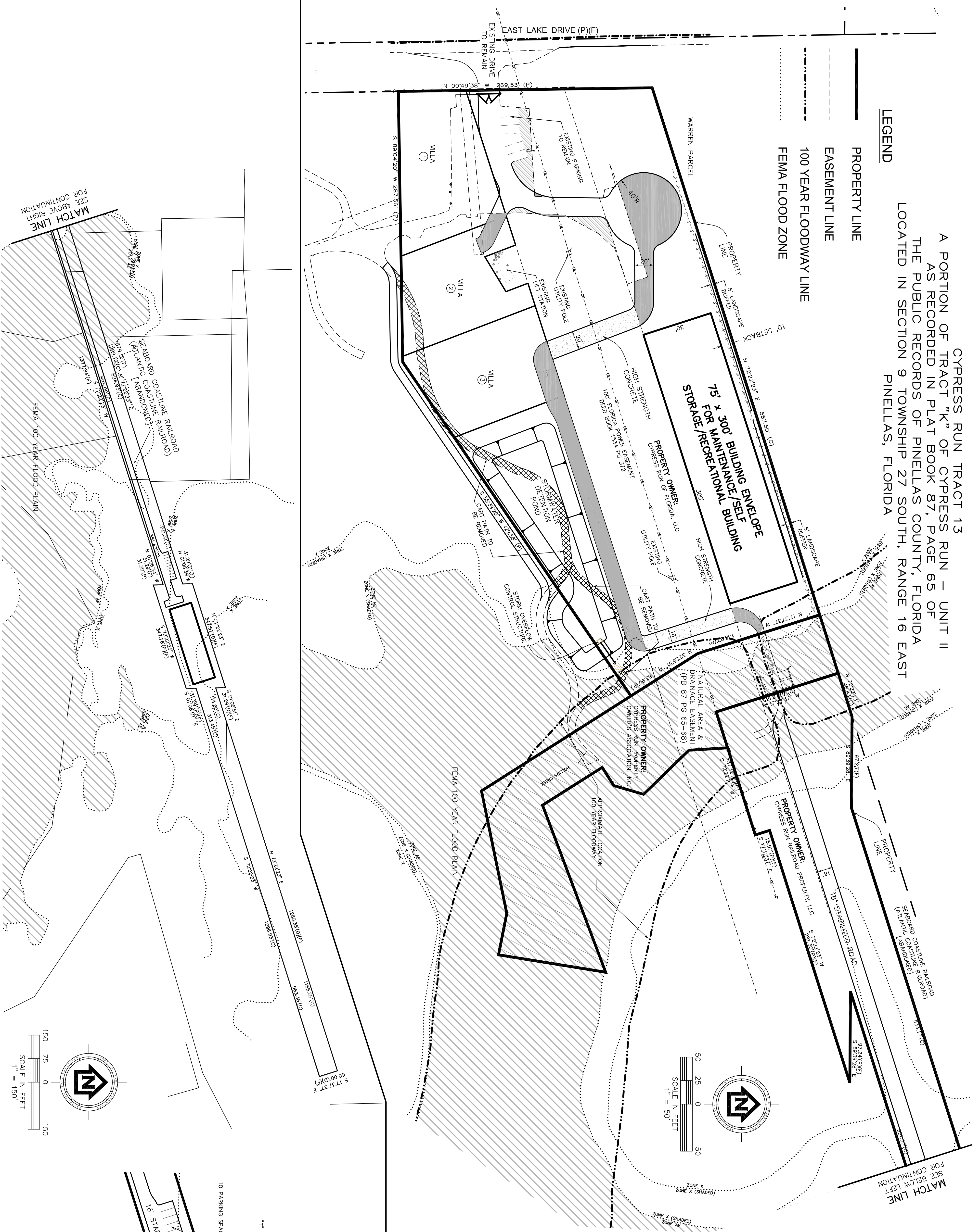
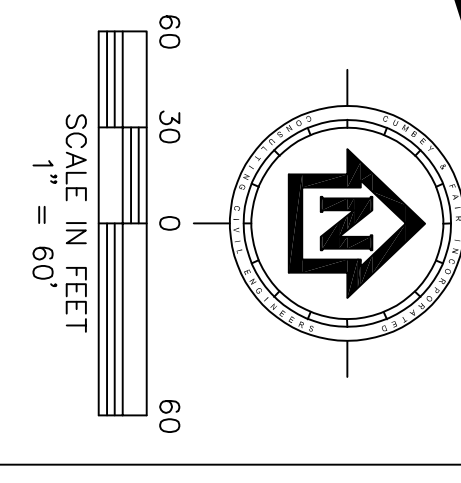
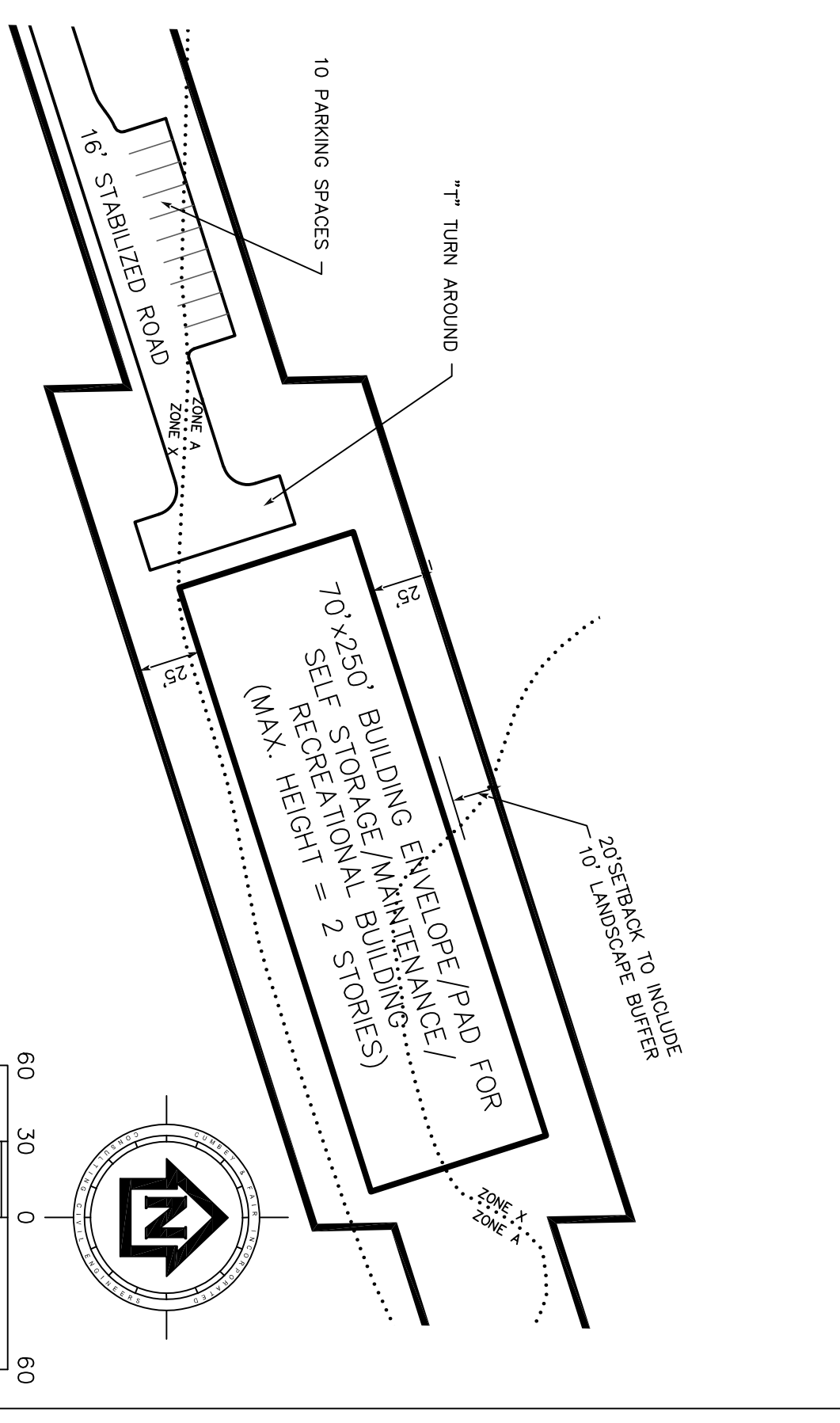

DETAIL

REVISIONS

BY	DATE	DESCRIPTION
RRD	7/18/23	REVISED LAYOUT
RRD	9/17/23	ADDED FEMA 100 YEAR FLOOD PLAIN

CUMBEY & FAIR, INC.
 CONSULTING CIVIL ENGINEERS
 CERTIFICATE OF AUTHORIZATION #00002168
 ENGINEERING PLANNING LAND SURVEYS
 2463 ENTERPRISE ROAD
 CLEARWATER, FLORIDA 33763-1790
 TAMPA (772) 791-4892
 TAMPA (813) 223-4333

FOR:
CYPRESS RUN OF FLORIDA, LLC
 2669 ST. ANDREWS BLVD.
 TARPON SPRINGS, FLORIDA 34688

DRWN BY:	RRD	DATE:	09/23
DSGN BY:	PJS	DATE:	09/23
CHKD BY:	PJS	DATE:	09/23

PROJECT CYPRESS RUN
 TRACT 13 & RAILROAD PARCEL

SHEET 1 OF 5
FRAMEWORK PLAN
 MASTER PLAN
 JOB NO. 20002.07

CYPRESS RUN TRACT 13
 A PORTION OF TRACT "K" OF CYPRESS RUN - UNIT II
 AS RECORDED IN PLAT BOOK 87, PAGE 65 OF
 THE PUBLIC RECORDS OF PINELLAS COUNTY, FLORIDA
 LOCATED IN SECTION 9 TOWNSHIP 27 SOUTH, RANGE 16 EAST
 PINELLAS, FLORIDA

- LEGEND**
- +—+—+— MINOR ARTERIAL
 - ⇄ EXISTING VEHICULAR ACCESS (TO REMAIN)
 - PROPERTY LINE
 - - - EASEMENT LINE
 - · - · - 100 YEAR FLOODWAY LINE
 - FEMA FLOOD ZONE

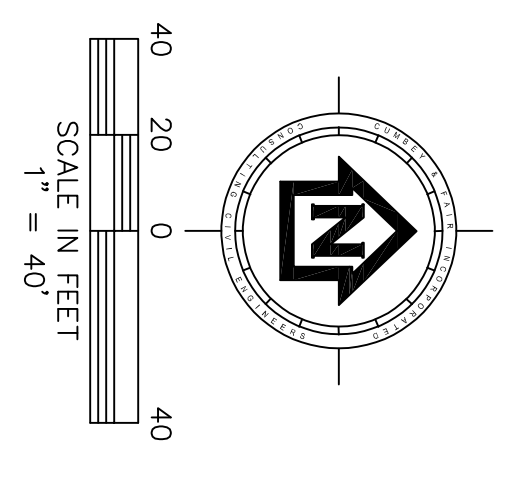
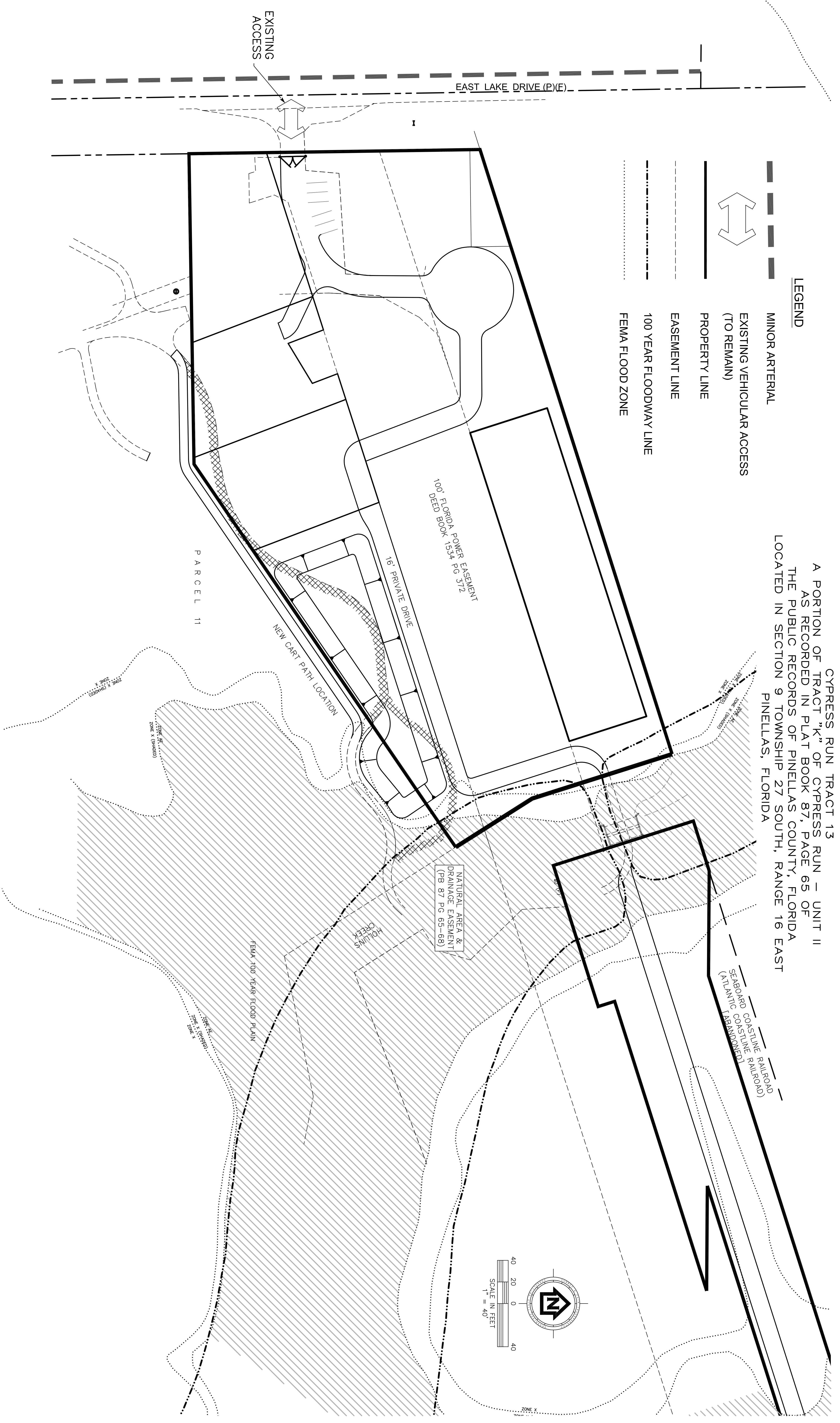

REVISIONS

BY	DATE	DESCRIPTION
RRD	7/18/23	REVISED LAYOUT
RRD	9/17/23	ADDED FEMA 100 YEAR FLOOD PLAIN

CUMBEY & FAIR, INC.
 CONSULTING CIVIL ENGINEERS
 CERTIFICATE OF AUTHORIZATION #00002168
 ENGINEERING PLANNING
 2463 ENTERPRISE ROAD
 CLEARWATER, FLORIDA 33763-1790

LAND SURVEYS
 CLEARWATER (772) 797-8982
 TAMPA (813) 223-4333

FOR:
CYPRESS RUN OF FLORIDA, LLC
 2669 ST. ANDREWS BLVD.
 TARPON SPRINGS, FLORIDA 34688

DRWN BY:	RRD	DATE	09/23
DSGN BY:	PJS	DATE	09/23
CHKD BY:	PJS	DATE	09/23

PROJECT	CYPRESS RUN TRACT 13 & RAILROAD PARCEL	SHEET	2 OF 5
FRAMEWORK PLAN	TRANSPORTATION PLAN	JOB NO.	20002.07

CURRENT FUTURE LAND USE MAP

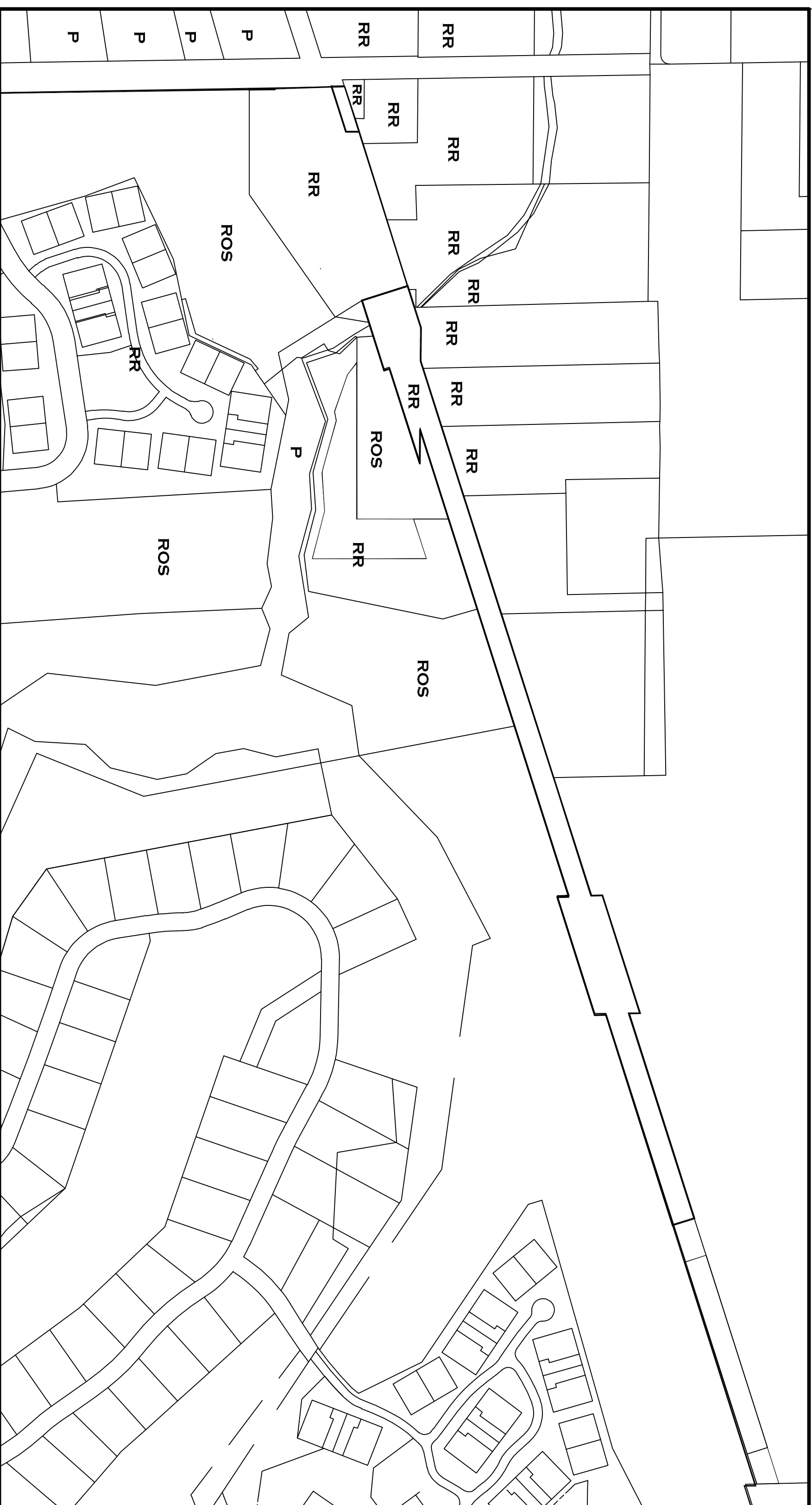

EXISTING ZONING MAP



PROPOSED FUTURE LAND USE MAP - NO CHANGE PROPOSED

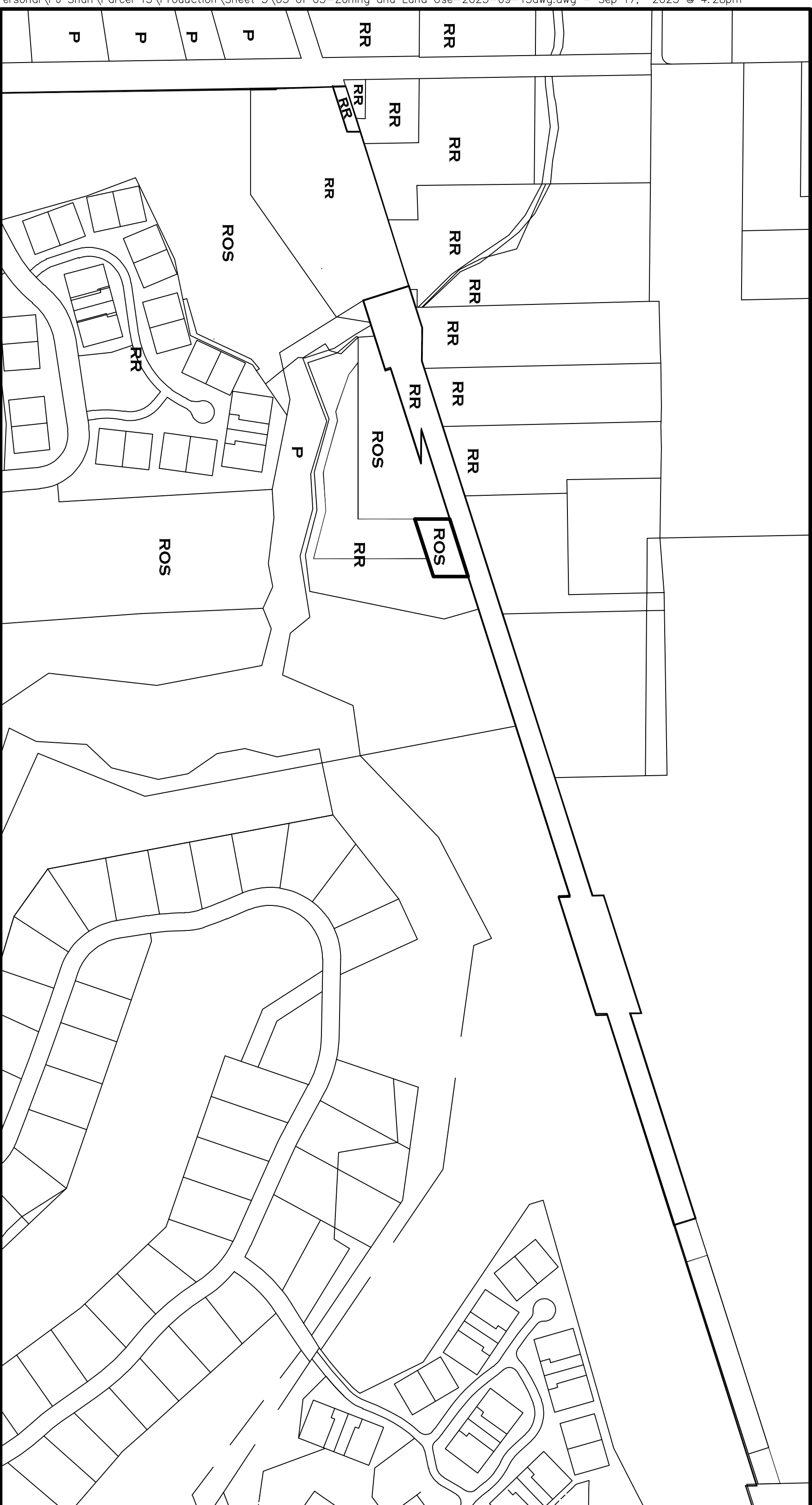

PROPOSED ZONING MAP

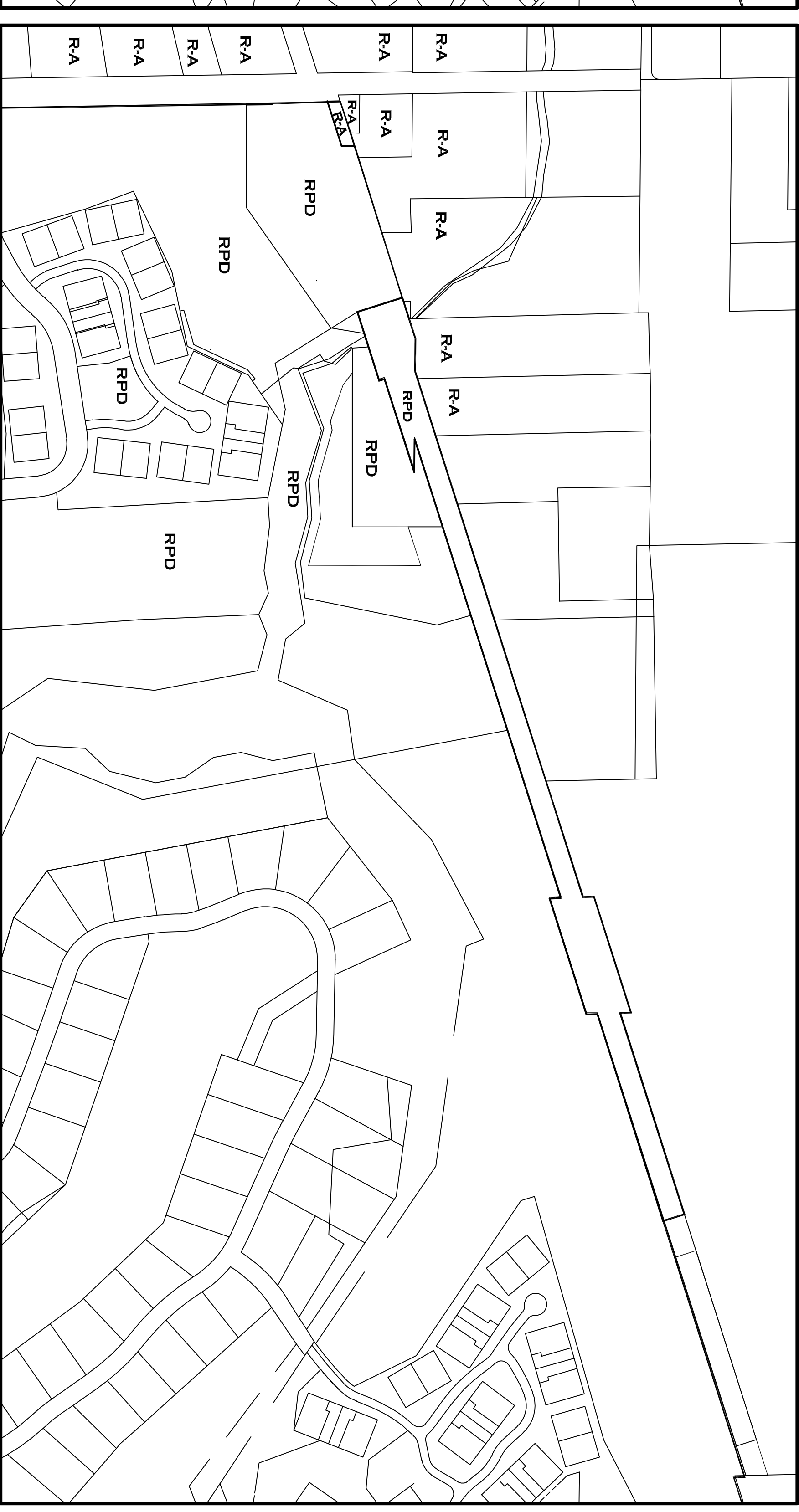

REVISIONS

BY	DATE	DESCRIPTION	BY	DATE	DESCRIPTION
RRD	7/18/23	REVISED LAYOUT			

CUMBEY & FAIR, INC.
CONSULTING CIVIL ENGINEERS
 CERTIFICATE OF AUTHORIZATION #00002168
 ENGINEERING PLANNING
 2463 ENTERPRISE ROAD
 CLEARWATER, FLORIDA 33763-1790

LAND SURVEYS
 CLEARWATER
 TAMPA
 (772) 791-8982
 (813) 223-4333

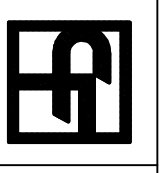

FOR:
CYPRESS RUN OF FLORIDA, LLC
 2669 ST. ANDREWS BLVD.
 TARPON SPRINGS, FLORIDA 34688

DRWN BY: RRD DATE 09/23
 DSGN BY: PJS DATE 09/23
 CHKD BY: PJS DATE 09/23

PROJECT **CYPRESS RUN TRACT 13 & RAILROAD PARCEL**

FRAMEWORK PLAN
 LAND USE & ZONING

SHEET **3 OF 5**
 JOB NO. **20002.07**

CYPRESS RUN TRACT 13
 A PORTION OF TRACT "K" OF CYPRESS RUN - UNIT II
 AS RECORDED IN PLAT BOOK 87, PAGE 65 OF
 THE PUBLIC RECORDS OF PINELLAS COUNTY, FLORIDA
 LOCATED IN SECTION 9 TOWNSHIP 27 SOUTH, RANGE 16 EAST
 PINELLAS, FLORIDA

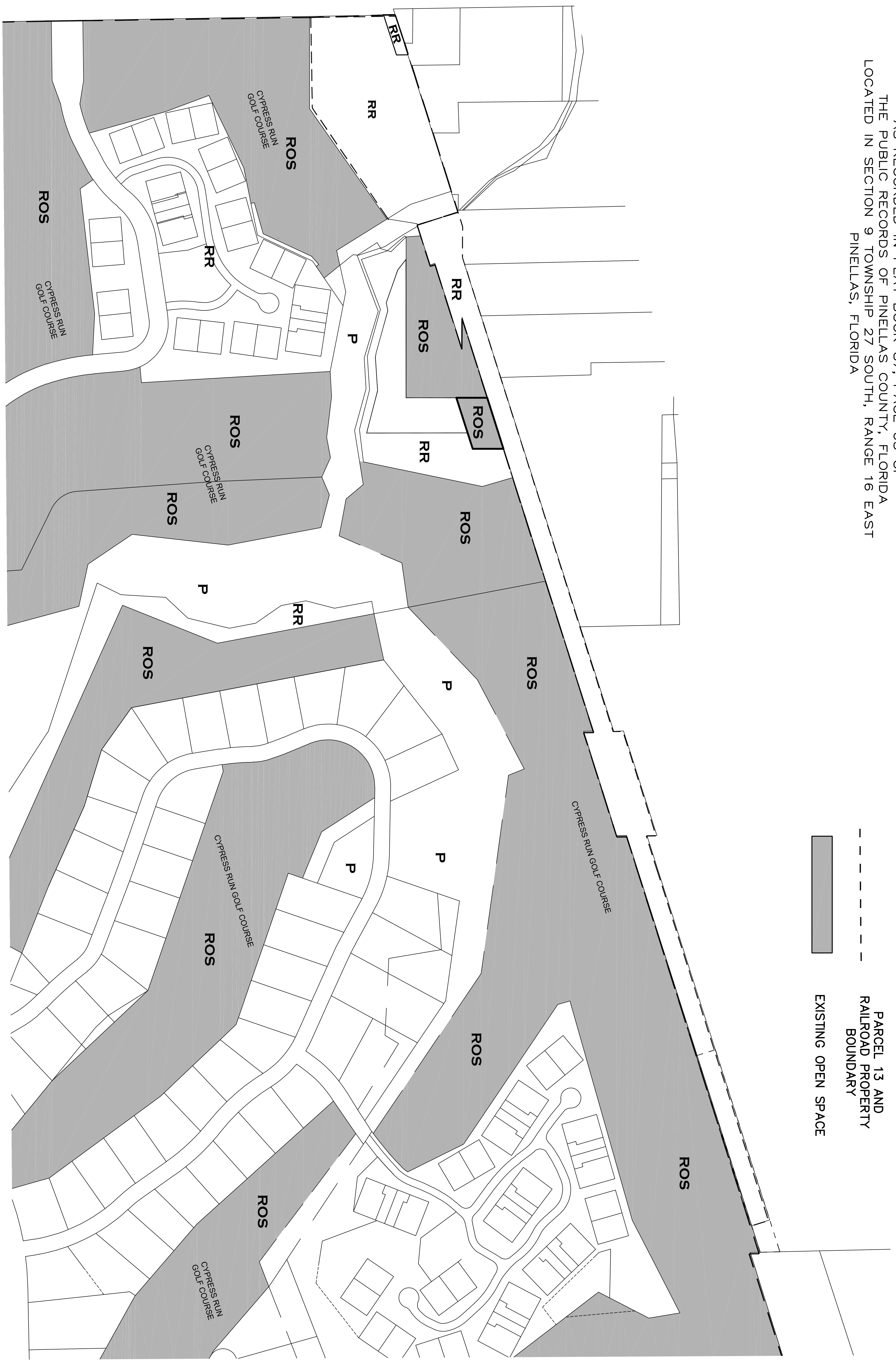

LEGEND

- RPD BOUNDARY
- PARCEL 13 AND RAILROAD PROPERTY BOUNDARY
- --- EXISTING OPEN SPACE

REVISIONS

BY	DATE	DESCRIPTION
RRD	7/18/23	REVISED LAYOUT

CUMBEY & FAIR, INC.
 CONSULTING CIVIL ENGINEERS
 CERTIFICATE OF AUTHORIZATION #00002168
 ENGINEERING PLANNING
 2463 ENTERPRISE ROAD
 CLEARWATER, FLORIDA 33763-1790

LAND SURVEYS
 CLEARWATER TAMPA
 (772) 797-8982
 (813) 223-4333

FOR:
CYPRESS RUN OF FLORIDA, LLC
 2669 ST. ANDREWS BLVD.
 TARPON SPRINGS, FLORIDA 34688

DRWN BY: RRD	DATE: 09/23
DSGN BY: PJS	DATE: 09/23
CHKD BY: PJS	DATE: 09/23

PROJECT
 CYPRESS RUN
 TRACT 13 & RAILROAD PARCEL

FRAMEWORK PLAN
 OPEN SPACE

SHEET
 4 OF 5
 JOB NO. 20002.07

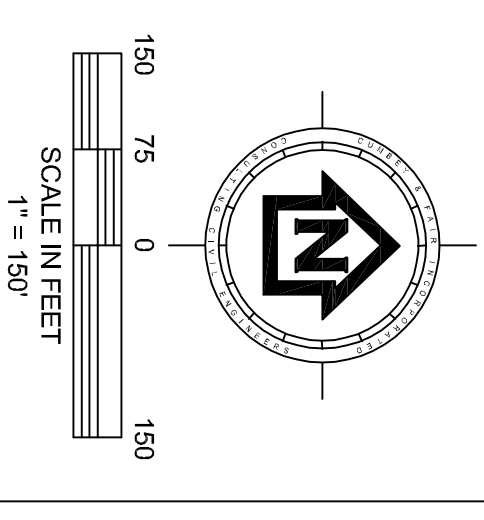

CYPRESS RUN TRACT 13
 A PORTION OF TRACT "K" OF CYPRESS RUN - UNIT II
 AS RECORDED IN PLAT BOOK 87, PAGE 65 OF
 THE PUBLIC RECORDS OF PINELLAS COUNTY, FLORIDA
 LOCATED IN SECTION 9 TOWNSHIP 27 SOUTH, RANGE 16 EAST
 PINELLAS, FLORIDA

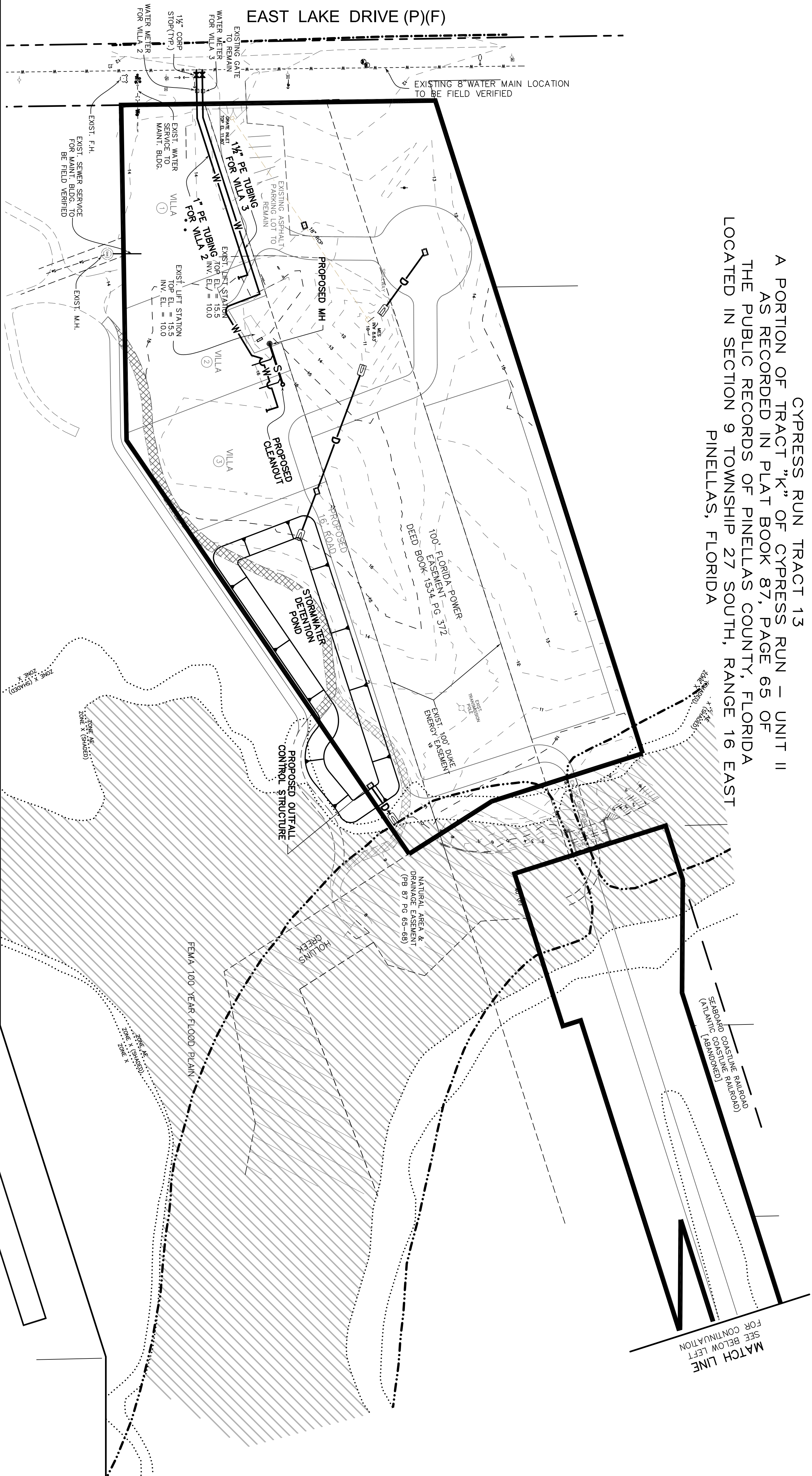

NOTE:
 SANITARY SEWER SERVICE SHALL BE BY SEPTIC TANK.
 WATER SERVICE SHALL BE BY WELL.

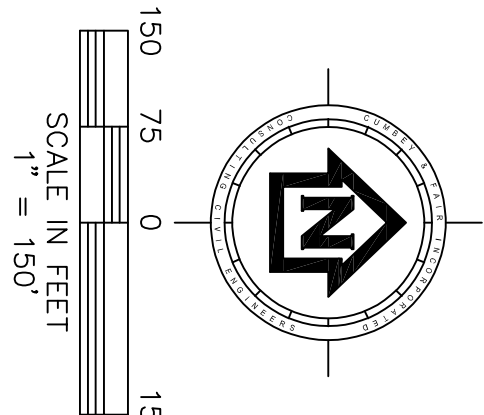
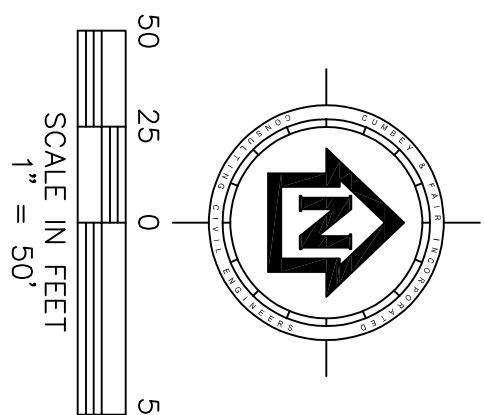
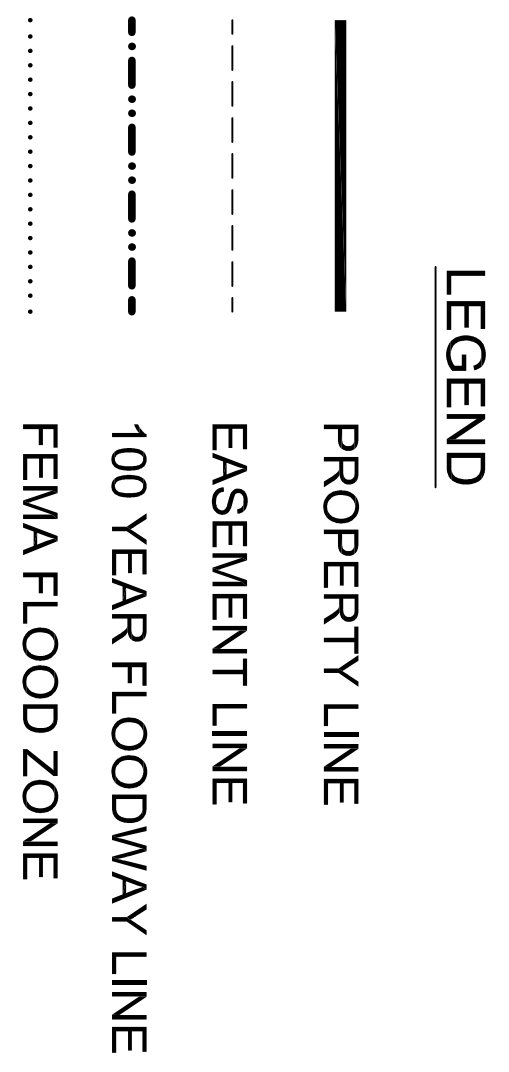

REVISIONS			
BY	DATE	DESCRIPTION	BY
RRD	7/18/23	REVISED LAYOUT	
RRD	9/15/23	ADDED FEMA 100 YEAR FLOOD PLAN	

CUMBEY & FAIR, INC.
 CONSULTING CIVIL ENGINEERS
 CERTIFICATE OF AUTHORIZATION #00002168
 ENGINEERING PLANNING LAND SURVEYS
 2463 ENTERPRISE ROAD
 CLEARWATER, FLORIDA 33763-1790
 TAMPA (772) 797-8982
 TAMPA (813) 223-4333

FOR:
CYPRESS RUN OF FLORIDA, LLC
 2669 ST. ANDREWS BLVD.
 TARPON SPRINGS, FLORIDA 34688

DRWN BY:	RRD	DATE	09/23
DSGN BY:	PJS	DATE	09/23
CHKD BY:	PJS	DATE	09/23

PROJECT
 CYPRESS RUN
 TRACT 13 & RAILROAD PARCEL

SHEET
 5 OF 5
 JOB NO.
 20002.07

**FRAMEWORK PLAN
 UTILITY AND DRAINAGE
 PLAN**