

# WILDS

BEING A PORTION OF THE NORTHEAST 1/4 OF SECTION 35, TOWNSHIP 27 SOUTH, RANGE 16 EAST, PINELLAS COUNTY, FLORIDA

## LEGAL DESCRIPTION

A TRACT OF LAND LYING IN THE NORTHEAST 1/4 OF SECTION 35, TOWNSHIP 27 SOUTH, RANGE 16 EAST, PINELLAS COUNTY, FLORIDA, BEING MORE PARTICULARLY DESCRIBED AS FOLLOWS:

COMMENCE AT THE SOUTHWEST CORNER OF THE NORTHEAST 1/4 OF SAID SECTION 35; THENCE S88°50'06"E, ALONG THE SOUTH BOUNDARY OF SAID NORTHEAST 1/4 OF SECTION 35, A DISTANCE OF 70.06 FEET; THENCE N01°14'07"W, ALONG A LINE LYING 70.00 FEET EAST OF AND PARALLEL TO THE WEST BOUNDARY OF SAID NORTHEAST 1/4 OF SECTION 35, A DISTANCE OF 100.09 FEET TO THE POINT OF BEGINNING; THENCE CONTINUE N01°14'07"W, ALONG SAID LINE, A DISTANCE OF 1,152.80 FEET; THENCE N89°49'53"E, ALONG THE NORTH BOUNDARY OF THE SOUTHWEST 1/4 OF THE NORTHEAST 1/4 OF SAID SECTION 35, A DISTANCE OF 779.99 FEET; THENCE S01°14'07"E, ALONG A LINE LYING 849.85 FEET EAST OF AND PARALLEL TO SAID WEST BOUNDARY OF THE NORTHEAST 1/4 OF SECTION 35, A DISTANCE OF 1,170.97 FEET; THENCE N88°50'06"W, ALONG A LINE LYING 100.00 FEET NORTH OF AND PARALLEL TO THE SOUTH BOUNDARY OF THE NORTHEAST 1/4 OF SAID SECTION 35, A DISTANCE OF 780.54 FEET TO THE POINT OF BEGINNING.

CONTAINING 906,101 SQUARE FEET OR 20.80 ACRES, MORE OR LESS.

## DEDICATION

WILDS LAND COMPANY, LLC, A FLORIDA LIMITED LIABILITY COMPANY, SOUTHWOOD PINELLAS, LLC, A FLORIDA LIMITED LIABILITY COMPANY, ROBERT VAN WORP, ROBERT E. VAN WORP, JUDSON VAN WORP, RONALD FRANK HARTMAN, JULIAN P. COSTAS, JR., VANITA COSTAS, SANJIV AMIN, AND SEEMA AMIN (COLLECTIVELY, THE "OWNERS") HEREBY STATE THAT THEY ARE THE LAWFUL OWNERS OF THE LAND REFERRED TO HEREON AS "WILDS" (THE "SUBDIVISION") AND THAT BESIDES THEIR INTERESTS THEREIN, THERE ARE NO OUTSTANDING INTERESTS IN SAID PROPERTY EXCEPT FOR THAT MORTGAGEE INTEREST HELD BY HI INVESTMENTS-FUNDING-FUND 2, LLC, MAINSTREET COMMUNITY BANK OF FLORIDA, STEPHEN A. SUSSMAN, AS THE PERSONAL REPRESENTATIVE OF THE ESTATE OF HARVEY P. SUSSMAN, AND U.S. BANK NATIONAL ASSOCIATION AND THAT THE OWNER(S) DO HEREBY MAKE THE FOLLOWING DEDICATIONS:

FEE INTEREST IN TRACT A, TRACT B, TRACT C, TRACT D, TRACT E AND TRACT F, AS SHOWN HEREON, IS HEREBY RESERVED BY THE OWNERS FOR CONVEYANCE BY SEPARATE INSTRUMENT TO THE WILDS PRESERVATION ASSOCIATION, INC., A FLORIDA CORPORATION NOT FOR PROFIT (THE "ASSOCIATION"), SUBSEQUENT TO THE RECORDING OF THIS PLAT, FOR THE BENEFIT OF THE LOT OWNERS WITHIN THE SUBDIVISION AND SHALL BE MAINTAINED BY THE ASSOCIATION.

THE PRIVATE EASEMENTS, AS SHOWN HEREON, ARE NOT DEDICATED TO THE PUBLIC AND ARE HEREBY DEDICATED BY THE OWNERS TO THE ASSOCIATION, WHO WILL HOLD RESPONSIBILITY FOR MAINTAINING THEM, FOR THE BENEFIT OF THE LOT OWNERS WITHIN THE SUBDIVISION. SAID RIGHTS WILL EXTEND TO LOT OWNERS, BOTH EXISTING AND FUTURE, OF THIS DEVELOPMENT.

THE PRIVATE ROADWAYS, LYING WITHIN TRACT E, ARE NOT DEDICATED TO THE PUBLIC AND ARE HEREBY DEDICATED BY THE OWNERS TO THE ASSOCIATION, FOR THE BENEFIT OF THE LOT OWNERS WITHIN THE SUBDIVISION AND SHALL BE MAINTAINED BY THE ASSOCIATION FOR INGRESS, EGRESS, DRAINAGE, STORMWATER, SEWER, POTABLE WATER, RECLAIMED WATER, UTILITY, PEDESTRIAN, AND LANDSCAPING PURPOSES. A NON-EXCLUSIVE ACCESS EASEMENT OVER TRACT E IS HEREBY GRANTED TO PINELLAS COUNTY AND ALL PROVIDERS OF LAW ENFORCEMENT, FIRE EMERGENCY, EMERGENCY MEDICAL, MAIL AND PACKAGE DELIVERY, SOLID WASTE SANITATION AND SIMILAR GOVERNMENTAL AND QUASI-GOVERNMENTAL SERVICE PROVIDERS FOR INGRESS AND EGRESS FOR THE PERFORMANCE OF OFFICIAL PUBLIC OR QUASI-PUBLIC DUTIES. SAID EASEMENT SHALL BE LIMITED TO ACCESS FOR THE AFOREMENTIONED PURPOSES AND SHALL NOT BE CONSTRUED AS CREATING A DEDICATED PUBLIC ROAD OR IMPOSING ANY MAINTENANCE OR OTHER RESPONSIBILITIES ON ANY OF THE AFOREMENTIONED PUBLIC OR QUASI-PUBLIC ENTITIES. A UTILITY EASEMENT OVER TRACT E IS HEREBY DEDICATED TO ANY PUBLIC OR PRIVATE UTILITY PROVIDER OR OTHER SIMILAR ENTITY PROVIDING UTILITY SERVICES TO THE LOTS AND TRACTS WITHIN THE SUBDIVISION, FOR THE CONSTRUCTION, MAINTENANCE, OPERATION AND REPAIR OF UTILITIES AND RELATED EQUIPMENT SERVING THE LOTS AND TRACTS. WILDS LAND COMPANY LLC (THE DEVELOPER) SHALL ALSO RETAIN NON-EXCLUSIVE PERPETUAL RIGHTS ACROSS, OVER AND UPON TRACT E FOR THE PURPOSES, INCLUDING INSTALLATION, MAINTENANCE AND REPLACEMENT OF ROADWAYS AND RELATED INFRASTRUCTURE, MORE PARTICULARLY DESCRIBED IN THE DECLARATION OF COVENANTS, CONDITIONS AND RESTRICTIONS FOR THE SUBDIVISION AND THE EXHIBITS ATTACHED THERETO, ALL AS DULY AMENDED FROM TIME TO TIME. SAID RIGHTS WILL EXTEND TO LOT OWNERS, BOTH EXISTING AND FUTURE, OF THIS DEVELOPMENT.

THE PUBLIC UTILITY EASEMENTS, AS SHOWN HEREON, ARE HEREBY DEDICATED BY THE OWNERS TO THE PUBLIC FOR ACCESS TO, CONSTRUCTION, INSTALLATION, RECONSTRUCTION, MAINTENANCE, IMPROVEMENT OR ALTERATION OF THE AREAS AS INDICATED FOR ALL UTILITIES, INCLUDING CABLEVISION AND COMMUNICATION PROVIDERS, AS MAY BE PROVIDED FOR, NOW OR IN THE FUTURE.

THE CONSERVATION EASEMENTS, AS SHOWN HEREON, ARE HEREBY DEDICATED TO PINELLAS COUNTY (AS PROVIDED IN SECTION 704.06, F.S.).

ALL IMPROVEMENTS WITHIN THE COMMON AREAS OF THE SUBDIVISION (INCLUDING, WITHOUT LIMITATION, ROADWAYS AND STORMWATER, IRRIGATION AND RETENTION FACILITIES, AND OPEN SPACES) ARE PRIVATE AND SHALL BE MAINTAINED BY THE ASSOCIATION.

SEE SHEET 2 OF 8 FOR CONTINUATION OF DEDICATION ACKNOWLEDGEMENTS AND SIGNATURES

## CONSERVATION EASEMENT NOTE

THE INTENT OF THE EASEMENT IS TO RETAIN THE EASEMENT AREA IN AN ESSENTIALLY NATURAL CONDITION. THE FOLLOWING ACTS OR ACTIVITIES ARE EXPRESSLY PROHIBITED WITHIN THE EASEMENT IN THE ABSENCE OF A SPECIFIC PERMIT FROM THE GRANTEE:

- (A) CONSTRUCTION OR THE PLACING OF ANY STRUCTURE OR MATERIALS ON OR ABOVE THE GROUND.  
(B) CONSTRUCTION OR PLACING OF UTILITIES, DRAINAGE FACILITIES, MITIGATION AREAS, OR THE PLANTING OF VEGETATION.  
(C) THE PLACEMENT OF ANY MATERIAL SUCH AS TRASH OR WASTE WHICH IS INCONSISTENT WITH THE INTENT OF THE CONSERVATION EASEMENT.  
(D) PLACEMENT, REMOVAL OR DESTRUCTION OF TREES, SHRUBS OR OTHER VEGETATION, INCLUDING MOWING, PESTICIDE AND HERBICIDE USES.  
(E) EXCAVATION OR OTHER REMOVAL OF MATERIAL.  
(F) USES EXCEPT FOR THE PURPOSES THAT PERMIT THE AREA DEFINED BY THE EASEMENT TO REMAIN IN AN ESSENTIALLY NATURAL CONDITION.  
(G) ANY ACTIVITY DETRIMENTAL TO DRAINAGE, FLOOD CONTROL, WATER CONSERVATION, EROSION CONTROL, SOIL CONSERVATION, OR FISH AND WILDLIFE HABITAT PRESERVATION.
- THE FOLLOWING RIGHTS ARE CONVEYED TO GRANTEE BY THIS EASEMENT:  
(A) TO ENTER UPON THE PROPERTY AT REASONABLE TIMES TO ENFORCE THE RIGHTS HEREIN GRANTED UPON PRIOR NOTICE TO GRANTOR, ITS HEIRS SUCCESSORS OR ASSIGNS AT THE TIME OF SUCH ENTRY.

\* PERMIT APPLICATIONS WILL BE REVIEWED ON A CASE-BY-CASE BASIS AND ARE NOT GUARANTEED TO BE GRANTED, BUT SUCH PERMITS SHALL NOT BE UNREASONABLY WITHHELD. THE REASONABLENESS OF A REQUEST IS INTERPRETED AND DETERMINED BY THE COUNTY AND PERMITS WILL NOT BE GRANTED SOLELY BECAUSE A PERMIT IS REQUESTED.



## CONFIRMATION OF ACCEPTANCE

THE WILDS PRESERVATION ASSOCIATION, LLC JOINS IN THE DEDICATION FOR THE PURPOSE OF ACCEPTING THE MAINTENANCE OF THE TRACTS A, B, C, D, E, & F AND PRIVATE EASEMENTS SITUATED IN THIS PLAT.

WILDS PRESERVATION ASSOCIATION, LLC

BY:   
MARC RUTENBERG  
MANAGING MEMBER

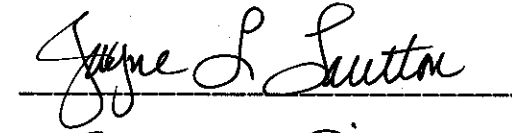
WITNESSES:

## ACKNOWLEDGMENT

STATE OF FLORIDA } S.S.  
COUNTY OF PINELLAS }

BEFORE ME, THE UNDERSIGNED AUTHORITY, BY MEANS OF  PHYSICAL PRESENCE OR  ONLINE NOTARIZATION, PERSONALLY APPEARED MARC RUTENBERG, AS MANAGING MEMBER OF THE WILDS PRESERVATION ASSOCIATION, LLC, AND HAS PRODUCED driver's license AS IDENTIFICATION AND IS KNOWN TO ME TO BE THE PERSON EXECUTING THE FOREGOING DEDICATION, AND HE ACKNOWLEDGED TO ME THAT HE EXECUTED THE SAME FOR THE PURPOSES SET OUT THEREIN AND DID (DO NOT) TAKE AN OATH.

WITNESS MY HAND AND OFFICIAL SEAL THIS 19th DAY OF July, 2023

  
NOTARY SIGNATURE

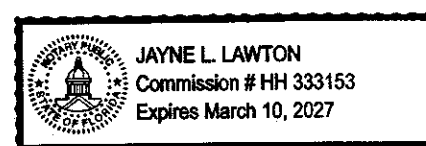

JAYNE L. LAWTON

NOTARY STAMP OR SEAL

PRINTED NAME OF NOTARY

## CERTIFICATE OF APPROVAL OF COUNTY COMMISSION

STATE OF FLORIDA } S.S.  
COUNTY OF PINELLAS }

IT IS HEREBY CERTIFIED THAT THIS PLAT HAS BEEN OFFICIALLY APPROVED FOR RECORD BY THE BOARD OF COUNTY COMMISSIONERS OF THE COUNTY OF PINELLAS, FLORIDA, THIS \_\_\_\_\_ DAY OF \_\_\_\_\_, 20\_\_\_\_.

APPROVED:

\_\_\_\_\_  
CHAIRMAN, BOARD OF  
COUNTY COMMISSIONERS

ATTEST: KEN BURKE, CLERK  
PINELLAS COUNTY, FLORIDA

BY: \_\_\_\_\_  
DEPUTY CLERK

## CERTIFICATE OF APPROVAL OF COUNTY CLERK

STATE OF FLORIDA } S.S.  
COUNTY OF PINELLAS }

I, KEN BURKE, CLERK OF THE CIRCUIT COURT OF PINELLAS COUNTY, FLORIDA, HEREBY CERTIFY THAT THIS PLAT HAS BEEN EXAMINED AND THAT IT COMPLIES IN FORM WITH ALL THE REQUIREMENTS OF THE STATUTES OF THE STATE OF FLORIDA PERTAINING TO MAPS AND PLATS, AND THAT THIS PLAT HAS BEEN FILED FOR RECORD IN PLAT BOOK \_\_\_\_\_, PAGES \_\_\_\_\_ THROUGH \_\_\_\_\_, PUBLIC RECORDS OF PINELLAS COUNTY, FLORIDA, THIS \_\_\_\_\_ DAY OF \_\_\_\_\_, 20\_\_\_\_.

KEN BURKE, CLERK  
PINELLAS COUNTY, FLORIDA

BY: \_\_\_\_\_  
DEPUTY CLERK

## CERTIFICATE OF CONFORMITY

I HEREBY CERTIFY THAT PURSUANT TO CHAPTER 177.081(1), FLORIDA STATUTES, I HAVE REVIEWED THIS PLAT AND FIND THAT IT CONFORMS TO CHAPTER 177, PART 1, OF THE FLORIDA STATUTES.

  
GREGORY DUQUE, PSM  
FLORIDA PROFESSIONAL SURVEYOR AND MAPPER  
LICENSE NUMBER: LS6647  
PINELLAS COUNTY SURVEY AND MAPPING DIVISION  
DEPARTMENT OF PUBLIC WORKS  
22211 U.S. HIGHWAY 19 NORTH  
CLEARWATER, FL 33765

7/27/2023  
DATE

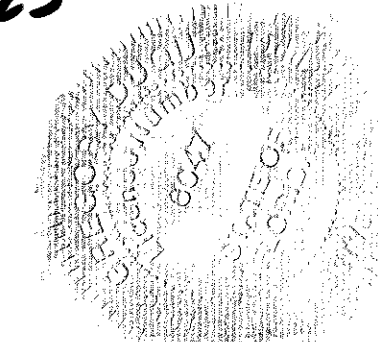

## SURVEYOR'S CERTIFICATE

I, GEORGE A. SHIMP II, THE UNDERSIGNED REGISTERED LAND SURVEYOR, HEREBY CERTIFY THAT ON July 18, 2023, THIS PROPERTY WAS SURVEYED UNDER MY SUPERVISION, THAT THIS PLAT WAS PREPARED UNDER MY DIRECTION AND SUPERVISION AND COMPLIES WITH ALL OF THE SURVEY REQUIREMENTS OF CHAPTER 177, PART 1, FLORIDA STATUTES, THAT THIS PLAT IS A TRUE REPRESENTATION OF THE LANDS DESCRIBED AND SHOWN, AND THAT PERMANENT REFERENCE MONUMENTS (P.R.M.'S), PERMANENT CONTROL POINTS (P.C.P.'S), LOT CORNERS AND TRACT CORNERS HAVE BEEN PLACED AS INDICATED HEREON IN ACCORDANCE WITH THE STATUTES OF THE STATE OF FLORIDA THERE-UNTO APPERTAINING. I ALSO HEREBY CERTIFY THAT THE MATERIALS AND COMPOSITION OF THIS PLAT CONFORMS TO THE REQUIREMENTS OF CHAPTER 177 PART 1, FLORIDA STATUTES.

  
GEORGE A. SHIMP II  
FLORIDA REGISTERED LAND SURVEYOR NO. 2512  
GEORGE A. SHIMP II & ASSOCIATES, INC. LB NO. 1834  
3301 DeSOTO BOULEVARD, SUITE D  
PALM HARBOR, FLORIDA 34683  
PHONE: 727-784-5496

7-18-23  
DATE

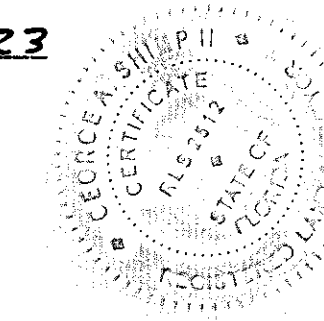

## SURVEYOR'S NOTES

- THE BEARINGS ARE BASED ON THE EAST RIGHT-OF-WAY OF HAWKS LANDING BOULEVARD, WHICH BEARS N01°14'07"W, ASSUMED.
- NOTICE: THIS PLAT, AS RECORDED IN ITS GRAPHIC FORM, IS THE OFFICIAL DEPICTION OF THE SUBDIVIDED LANDS DESCRIBED HEREIN AND WILL IN NO CIRCUMSTANCES BE SUPPLANTED IN AUTHORITY BY ANY OTHER GRAPHIC OR DIGITAL FORM OF THE PLAT. THERE MAY BE ADDITIONAL RESTRICTIONS THAT ARE NOT RECORDED ON THIS PLAT THAT MAY BE FOUND IN THE PUBLIC RECORDS OF THIS COUNTY.
- ALL PLATTED UTILITY EASEMENTS SHALL PROVIDE THAT SUCH EASEMENTS SHALL ALSO BE EASEMENTS FOR THE CONSTRUCTION, INSTALLATION, MAINTENANCE, AND OPERATION OF CABLE TELEVISION SERVICES; PROVIDED, HOWEVER, NO SUCH CONSTRUCTION, INSTALLATION, MAINTENANCE, AND OPERATION OF CABLE TELEVISION SERVICES SHALL INTERFERE WITH THE FACILITIES AND SERVICES OF AN ELECTRIC, TELEPHONE, GAS, OR OTHER PUBLIC UTILITY. IN THE EVENT A CABLE TELEVISION COMPANY DAMAGES THE FACILITIES OF A PUBLIC UTILITY, IT SHALL BE SOLELY RESPONSIBLE FOR THE DAMAGES. THIS SECTION SHALL NOT APPLY TO THOSE PRIVATE EASEMENTS GRANTED TO OR OBTAINED BY A PARTICULAR ELECTRIC, TELEPHONE, GAS, OR OTHER PUBLIC UTILITY. SUCH CONSTRUCTION, INSTALLATION, MAINTENANCE, AND OPERATION SHALL COMPLY WITH THE NATIONAL ELECTRICAL SAFETY CODE AS ADOPTED BY THE FLORIDA PUBLIC SERVICE COMMISSION.

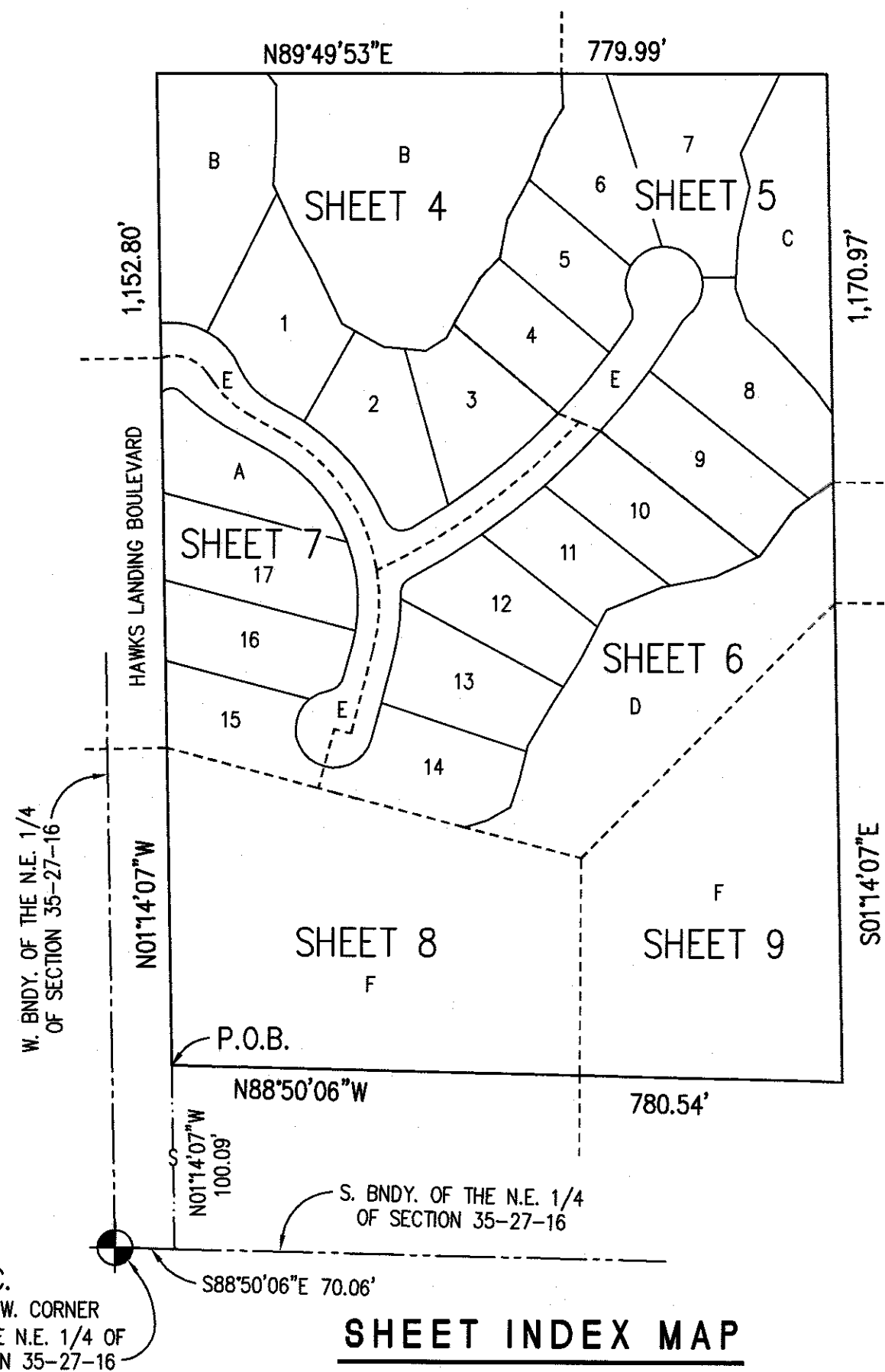

SHEET INDEX MAP  
(NOT TO SCALE)

 **GEORGE A SHIMP II**  
**and ASSOCIATES, INC.**  
LAND SURVEYING and PLANNING  
3301 DeSOTO BOULEVARD, SUITE D  
PALM HARBOR, FLORIDA 34683  
PHONE (727) 784-5496 FAX (727) 786-1256  
R.L.S. No. 2512 L.B. No. 1834

# WILDS

BEING A PORTION OF THE NORTHEAST 1/4 OF SECTION 35, TOWNSHIP 27 SOUTH, RANGE 16 EAST, PINELLAS COUNTY, FLORIDA

### OWNER AS TO LOTS 3, 5-9, 11-17 AND TRACTS A-E

MARC RUTENBERG, AUTHORIZED MEMBER, WILDS LAND COMPANY, LLC, A FLORIDA LIMITED LIABILITY COMPANY

*Jayne L. Lawton* WITNESS *Judith A. Romano* WITNESS

### ACKNOWLEDGMENT

STATE OF FLORIDA } S.S.  
COUNTY OF PINELLAS

BEFORE ME, THE UNDERSIGNED AUTHORITY, BY MEANS OF  PHYSICAL PRESENCE OR  ONLINE NOTARIZATION, PERSONALLY APPEARED MARC RUTENBERG, AS AUTHORIZED MEMBER OF WILDS LAND COMPANY, LLC, A FLORIDA LIMITED LIABILITY COMPANY, AND HAS PRODUCED driver's license AS IDENTIFICATION AND IS KNOWN TO ME TO BE THE PERSON EXECUTING THE FOREGOING DEDICATION, AND HE ACKNOWLEDGED TO ME THAT HE EXECUTED THE SAME FOR THE PURPOSES SET OUT THEREIN AND DID (DID NOT) TAKE AN OATH.

WITNESS MY HAND AND OFFICIAL SEAL THIS 19th DAY OF July, 2023

*Jayne L. Lawton*  
NOTARY SIGNATURE

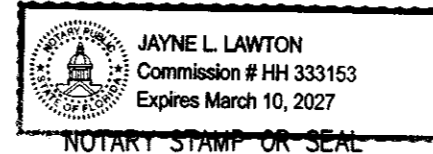

JAYNE L. LAWTON  
PRINTED NAME OF NOTARY

### MORTGAGEE'S CONSENT TO PLAT

H/I INVESTMENTS AND FUNDING - FUND 2, LLC, A FLORIDA LIMITED LIABILITY COMPANY, AS MORTGAGEE UNDER CERTAIN MORTGAGE DATED SEPTEMBER 25, 2019, RECORDED IN O.R. BOOK 20711, PAGE 1207, PUBLIC RECORDS OF PINELLAS COUNTY, FLORIDA, AS ASSIGNED TO MAINSTREET COMMUNITY BANK OF FLORIDA, AS MORTGAGEE UNDER CERTAIN COLLATERAL ASSIGNMENT OF NOTE AND MORTGAGE RECORDED ON JULY 1, 2020 IN O.R. BOOK 21060, PAGE 1275, PUBLIC RECORDS OF PINELLAS COUNTY, FLORIDA, BY THE CONSENT TO PLATTING AS RECORDED IN O.R. BOOK 21669, PAGE 1459 DOES JOIN IN AND CONSENT TO THE DEDICATION OF THE LANDS DESCRIBED HEREON, AND AGREES THAT IN THE EVENT OF THE FORECLOSURE OF THIS MORTGAGE ALL DEDICATED AREAS SHALL SURVIVE AND BE ENFORCEABLE.

STEPHEN A. SUSSMAN, AS THE PERSONAL REPRESENTATIVE OF THE ESTATE OF HARVEY P. SUSSMAN, AS MORTGAGEE UNDER CERTAIN MORTGAGE DATED MAY 8, 2023, RECORDED IN O.R. BOOK 22438, PAGE 1354, PUBLIC RECORDS OF PINELLAS COUNTY, FLORIDA, BY THE CONSENT TO PLATTING AS RECORDED IN O.R. BOOK 22441, PAGE 1450, DOES JOIN IN AND CONSENT TO THE DEDICATION OF WILDS DESCRIBED HEREON, AND AGREES THAT IN THE EVENT OF THE FORECLOSURE OF THIS MORTGAGE ALL DEDICATED AREAS SHALL SURVIVE AND BE ENFORCEABLE.

### OWNER AS TO TRACT F

MARC RUTENBERG, AUTHORIZED MEMBER, SOUTHWOOD PINELLAS, LLC, A FLORIDA LIMITED LIABILITY COMPANY

*Jayne L. Lawton* WITNESS *Judith A. Romano* WITNESS

### ACKNOWLEDGMENT

STATE OF FLORIDA } S.S.  
COUNTY OF PINELLAS

BEFORE ME, THE UNDERSIGNED AUTHORITY, BY MEANS OF  PHYSICAL PRESENCE OR  ONLINE NOTARIZATION, PERSONALLY APPEARED MARC RUTENBERG, AS AUTHORIZED MEMBER OF SOUTHWOOD PINELLAS, LLC, A FLORIDA LIMITED LIABILITY COMPANY, AND HAS PRODUCED driver's license AS IDENTIFICATION AND IS KNOWN TO ME TO BE THE PERSON EXECUTING THE FOREGOING DEDICATION, AND HE ACKNOWLEDGED TO ME THAT HE EXECUTED THE SAME FOR THE PURPOSES SET OUT THEREIN AND DID (DID NOT) TAKE AN OATH.

WITNESS MY HAND AND OFFICIAL SEAL THIS 19th DAY OF July, 2023

*Jayne L. Lawton*  
NOTARY SIGNATURE

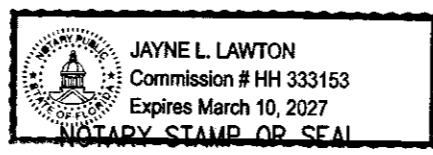

JAYNE L. LAWTON  
PRINTED NAME OF NOTARY

### MORTGAGEE'S CONSENT TO PLAT

H/I INVESTMENTS AND FUNDING - FUND 2, LLC, A FLORIDA LIMITED LIABILITY COMPANY, AS MORTGAGEE UNDER CERTAIN MORTGAGE DATED SEPTEMBER 25, 2019, RECORDED IN O.R. BOOK 20711, PAGE 1207, PUBLIC RECORDS OF PINELLAS COUNTY, FLORIDA, AS ASSIGNED TO MAINSTREET COMMUNITY BANK OF FLORIDA, AS MORTGAGEE UNDER CERTAIN COLLATERAL ASSIGNMENT OF NOTE AND MORTGAGE RECORDED ON JULY 1, 2020 IN O.R. BOOK 21060, PAGE 1275, PUBLIC RECORDS OF PINELLAS COUNTY, FLORIDA, BY THE CONSENT TO PLATTING AS RECORDED IN O.R. BOOK 21669, PAGE 1459 DOES JOIN IN AND CONSENT TO THE DEDICATION OF THE LANDS DESCRIBED HEREON, AND AGREES THAT IN THE EVENT OF THE FORECLOSURE OF THIS MORTGAGE ALL DEDICATED AREAS SHALL SURVIVE AND BE ENFORCEABLE.

### OWNER AS TO LOT 1

*Julian P. Costas Jr & Vanita Costas*  
by *William J. Kimpton* in fact  
JULIAN P. COSTAS, JR. & VANITA COSTAS  
BY THEIR ATTORNEY-IN-FACT, WILLIAM J. KIMPTON

*Jayne L. Lawton* WITNESS *Judith A. Romano* WITNESS

### ACKNOWLEDGMENT

STATE OF FLORIDA } S.S.  
COUNTY OF PINELLAS

BEFORE ME, THE UNDERSIGNED AUTHORITY, BY MEANS OF  PHYSICAL PRESENCE OR  ONLINE NOTARIZATION, PERSONALLY APPEARED WILLIAM J. KIMPTON, AS ATTORNEY-IN-FACT FOR RONALD FRANK HARTMAN, AND HAS PRODUCED driver's license AS IDENTIFICATION AND IS KNOWN TO ME TO BE THE PERSON EXECUTING THE FOREGOING DEDICATION, AND HE ACKNOWLEDGED TO ME THAT HE EXECUTED THE SAME FOR THE PURPOSES SET OUT THEREIN AND DID (DID NOT) TAKE AN OATH.

WITNESS MY HAND AND OFFICIAL SEAL THIS 19th DAY OF July, 2023

*Jayne L. Lawton*  
NOTARY SIGNATURE

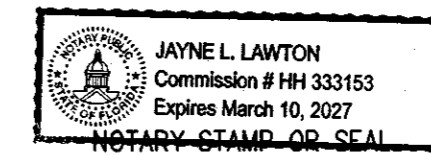

JAYNE L. LAWTON  
PRINTED NAME OF NOTARY

### OWNER AS TO LOT 2

*Sanjiv Amin & Seema Amin*  
by *William J. Kimpton* in fact  
SANJIV AMIN & SEEMA AMIN  
BY THEIR ATTORNEY-IN-FACT, WILLIAM J. KIMPTON

*Jayne L. Lawton* WITNESS *Judith A. Romano* WITNESS

### ACKNOWLEDGMENT

STATE OF FLORIDA } S.S.  
COUNTY OF PINELLAS

BEFORE ME, THE UNDERSIGNED AUTHORITY, BY MEANS OF  PHYSICAL PRESENCE OR  ONLINE NOTARIZATION, PERSONALLY APPEARED WILLIAM J. KIMPTON, AS ATTORNEY-IN-FACT FOR ROBERT VAN WORP, ROBERT E. VAN WORP, JUDSON VAN WORP, AND HAS PRODUCED driver's license AS IDENTIFICATION AND IS KNOWN TO ME TO BE THE PERSON EXECUTING THE FOREGOING DEDICATION, AND HE ACKNOWLEDGED TO ME THAT HE EXECUTED THE SAME FOR THE PURPOSES SET OUT THEREIN AND DID (DID NOT) TAKE AN OATH.

WITNESS MY HAND AND OFFICIAL SEAL THIS 19th DAY OF July, 2023

*Jayne L. Lawton*  
NOTARY SIGNATURE

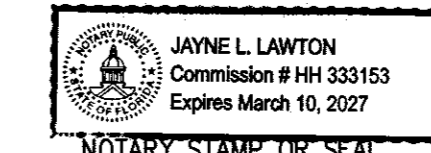

JAYNE L. LAWTON  
PRINTED NAME OF NOTARY

### MORTGAGEE'S CONSENT TO PLAT

U.S. BANK NATIONAL ASSOCIATION, AS MORTGAGEE UNDER CERTAIN MORTGAGE DATED AUGUST 24, 2022, RECORDED IN O.R. BOOK 22184, PAGE 2240, PUBLIC RECORDS OF PINELLAS COUNTY, FLORIDA, BY THE CONSENT TO PLATTING AS RECORDED IN O.R. BOOK 22296, PAGE 415 DOES JOIN IN AND CONSENT TO THE DEDICATION OF THE LANDS DESCRIBED HEREON, AND AGREES THAT IN THE EVENT OF THE FORECLOSURE OF THIS MORTGAGE ALL DEDICATED AREAS SHALL SURVIVE AND BE ENFORCEABLE.

SEE SHEET 3 OF 9 FOR A CONTINUATION OF THE OWNER ACKNOWLEDGMENTS.

 **GEORGE A SHIMP II**  
**and ASSOCIATES, INC.**  
LAND SURVEYING and PLANNING  
3301 DeSOTO BOULEVARD, SUITE D  
PALM HARBOR, FLORIDA 34683  
PHONE (727) 784-5496 FAX (727) 786-1256  
R.L.S. No. 2512 L.B. No. 1834

# WILDS

BEING A PORTION OF THE NORTHEAST 1/4 OF SECTION 35, TOWNSHIP 27 SOUTH, RANGE 16 EAST, PINELLAS COUNTY, FLORIDA

CONTINUATION OF THE OWNER ACKNOWLEDGMENTS.

OWNER AS TO LOT 4  
*Ronald Frank Hartman*  
*by his attorney in fact*  
RONALD FRANK HARTMAN, BY HIS ATTORNEY-IN-FACT, WILLIAM J. KIMPTON

*Jayne L. Lawton*  
WITNESS

*Judith A. Demico*  
WITNESS

### ACKNOWLEDGMENT

STATE OF FLORIDA } S.S.  
COUNTY OF PINELLAS }

BEFORE ME, THE UNDERSIGNED AUTHORITY, BY MEANS OF  PHYSICAL PRESENCE OR  ONLINE NOTARIZATION, PERSONALLY APPEARED WILLIAM J. KIMPTON, AS ATTORNEY-IN-FACT FOR RONALD FRANK HARTMAN, AND HAS PRODUCED *driver's license* AS IDENTIFICATION AND IS KNOWN TO ME TO BE THE PERSON EXECUTING THE FOREGOING DEDICATION, AND HE ACKNOWLEDGED TO ME THAT HE EXECUTED THE SAME FOR THE PURPOSES SET OUT THEREIN AND DID (DID NOT) TAKE AN OATH.

WITNESS MY HAND AND OFFICIAL SEAL THIS 19<sup>th</sup> DAY OF July, 2023

*Jayne L. Lawton*  
NOTARY SIGNATURE

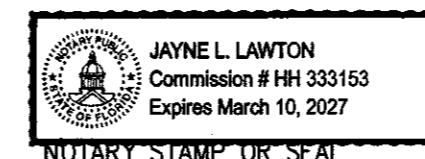

JAYNE L. LAWTON  
PRINTED NAME OF NOTARY

OWNER AS TO LOT 10  
*Robert Van Worp, Robert E. Van Worp, Judson Van Worp*  
*by their attorney in fact*  
ROBERT VAN WORP, ROBERT E. VAN WORP AND JUDSON VAN WORP  
BY THEIR ATTORNEY-IN-FACT, WILLIAM J. KIMPTON

*Jayne L. Lawton*  
WITNESS

*Judith A. Demico*  
WITNESS

### ACKNOWLEDGMENT

STATE OF FLORIDA } S.S.  
COUNTY OF PINELLAS }

BEFORE ME, THE UNDERSIGNED AUTHORITY, BY MEANS OF  PHYSICAL PRESENCE OR  ONLINE NOTARIZATION, PERSONALLY APPEARED WILLIAM J. KIMPTON, AS ATTORNEY-IN-FACT FOR ROBERT VAN WORP, ROBERT E. VAN WORP, JUDSON VAN WORP, AND HAS PRODUCED *driver's license* AS IDENTIFICATION AND IS KNOWN TO ME TO BE THE PERSON EXECUTING THE FOREGOING DEDICATION, AND HE ACKNOWLEDGED TO ME THAT HE EXECUTED THE SAME FOR THE PURPOSES SET OUT THEREIN AND DID (DID NOT) TAKE AN OATH.

WITNESS MY HAND AND OFFICIAL SEAL THIS 19<sup>th</sup> DAY OF July, 2023

*Jayne L. Lawton*  
NOTARY SIGNATURE

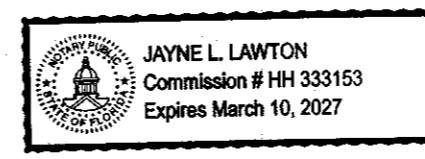

JAYNE L. LAWTON  
PRINTED NAME OF NOTARY

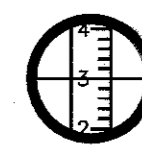
 **GEORGE A SHIMP II**  
**and ASSOCIATES, INC.**  
LAND SURVEYING and PLANNING  
3301 DeSOTO BOULEVARD, SUITE D  
PALM HARBOR, FLORIDA 34683  
PHONE (727) 784-5496 FAX (727) 786-1256  
R.L.S. No. 2512 L.B. No. 1834



# WILDS

BEING A PORTION OF THE NORTHEAST 1/4 OF SECTION 35, TOWNSHIP 27 SOUTH, RANGE 16 EAST, PINELLAS COUNTY, FLORIDA

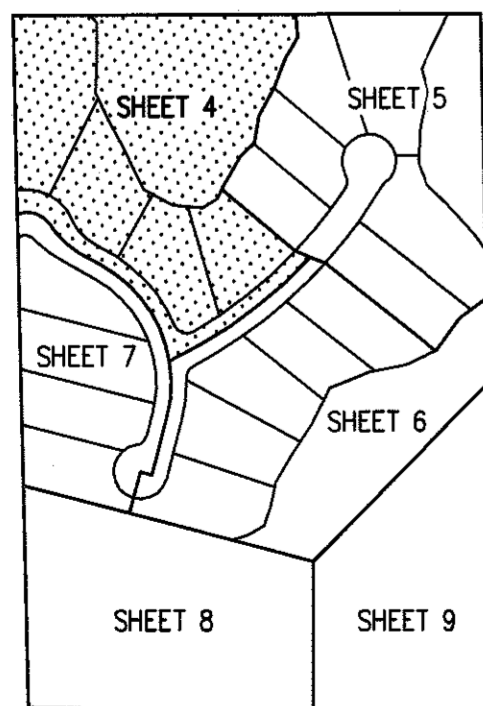
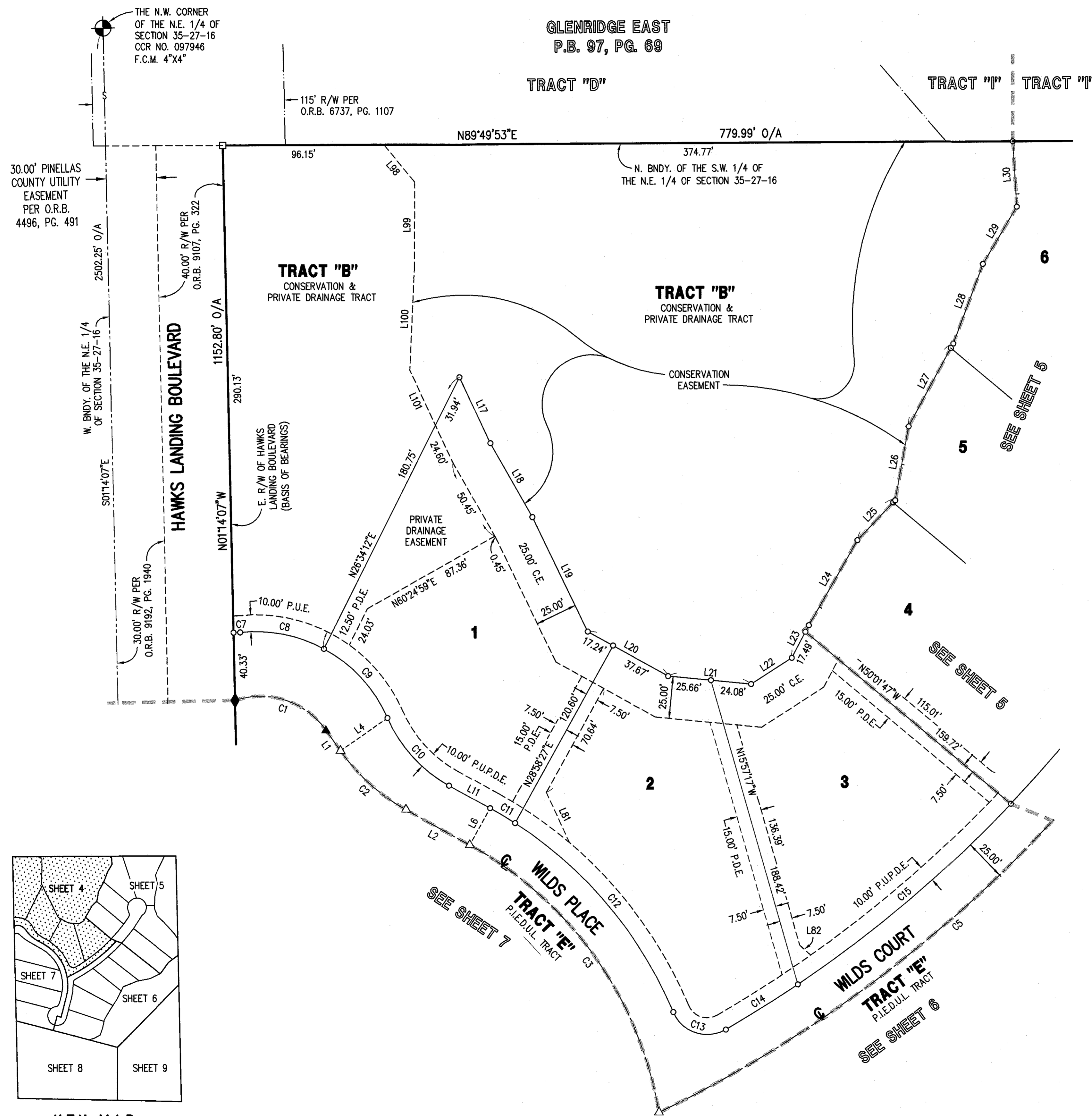

**KEY MAP**  
(NOT TO SCALE)

GLENRIDGE EAST  
P.B. 97, PG. 69

TRACT "D"

TRACT "I" TRACT "I"

TRACT "B"  
CONSERVATION &  
PRIVATE DRAINAGE TRACT

TRACT "B"  
CONSERVATION &  
PRIVATE DRAINAGE TRACT

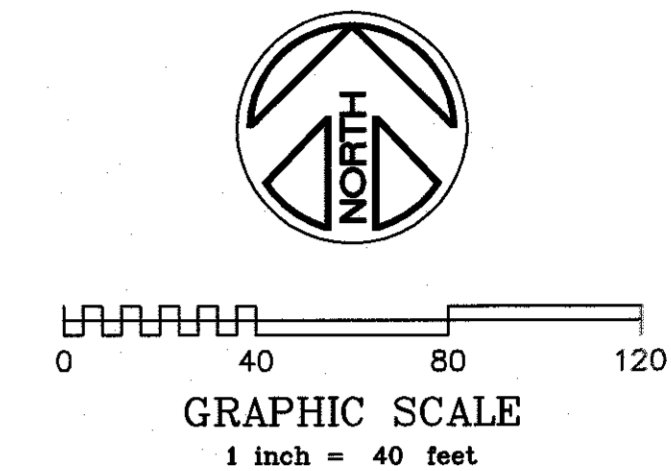

SEE SHEET 6 FOR LEGEND

LINE DATA		
LINE	BEARING	DISTANCE
L1	N35°03'27"W	15.09'
L2	N61°01'33"W	43.42'
L4	N55°06'01"E	34.18'
L6	N28°58'27"E	25.00'
L11	S61°01'33"E	27.85'
L14	NOT USED	NOT USED
L15	NOT USED	NOT USED
L16	NOT USED	NOT USED
L17	S24°56'50"E	43.46'
L18	S29°35'01"E	50.71'
L19	S25°47'45"E	75.75'
L20	S61°01'33"E	54.91'
L21	S84°22'52"E	49.74'
L22	N57°21'14"E	28.82'
L23	N27°36'02"E	21.89'
L24	N29°51'40"E	58.28'
L25	N43°39'06"E	32.68'
L26	N10°22'22"E	44.67'
L27	N28°15'21"E	56.01'
L28	N20°24'28"E	50.54'
L29	N30°48'09"E	39.54'
L30	N03°29'36"W	39.01'
L81	N24°40'44"W	32.85'
L82	N47°32'32"W	8.86'
L98	S39°25'58"E	28.68'
L99	S00°09'45"W	51.34'
L100	S02°35'00"W	60.74'
L101	S24°56'50"E	36.16'

CURVE TABLE					
CURVE	RADIUS	ARC	CHORD	CHORD BEARING	DELTA
C1	47.66'	61.20'	57.08'	N71°50'47"W	73°34'40"
C2	116.72'	52.90'	52.45'	N48°02'30"W	25°58'06"
C3	225.00'	202.31'	195.56'	N35°18'01"W	51°31'05"
C5	783.72'	482.01'	474.45'	N46°38'04"E	35°14'19"
C7	30.00'	3.95'	3.94'	N87°42'37"E	7°32'14"
C8	86.00'	51.71'	50.94'	S78°49'57"E	34°27'05"
C9	86.00'	57.01'	55.97'	S42°37'01"E	37°58'47"
C10	85.00'	55.48'	54.50'	S42°19'36"E	37°23'55"
C11	250.00'	17.36'	17.36'	S59°02'10"E	3°58'46"
C12	250.00'	149.28'	147.07'	S39°56'26"E	34°12'41"
C13	22.00'	37.34'	33.02'	S71°27'20"E	97°14'29"
C14	758.72'	50.69'	50.68'	N58°00'35"E	3°49'41"
C15	758.72'	166.51'	166.18'	N49°48'31"E	12°34'27"

**GEORGE A SHIMP II**  
*and ASSOCIATES, INC.*  
LAND SURVEYING and PLANNING  
3301 DeSOTO BOULEVARD, SUITE D  
PALM HARBOR, FLORIDA 34683  
PHONE (727) 784-5496 FAX (727) 786-1256  
R.L.S. No. 2512 L.B. No. 1834

# WILDS

BEING A PORTION OF THE NORTHEAST 1/4 OF SECTION 35, TOWNSHIP 27 SOUTH, RANGE 16 EAST, PINELLAS COUNTY, FLORIDA

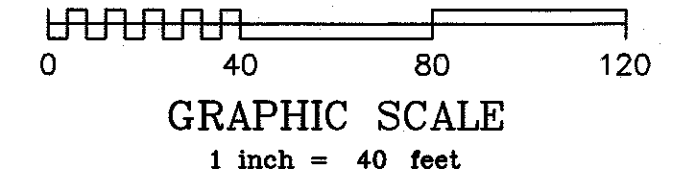
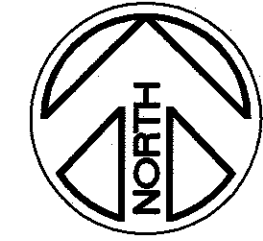

SEE SHEET 6 FOR LEGEND

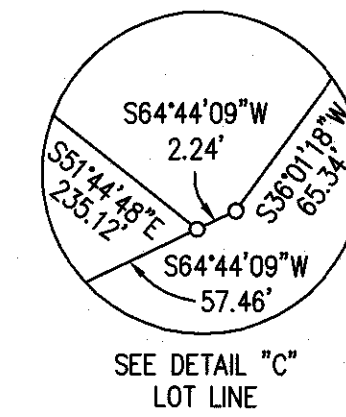
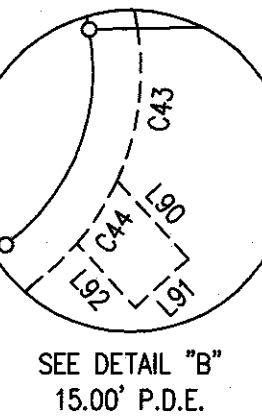
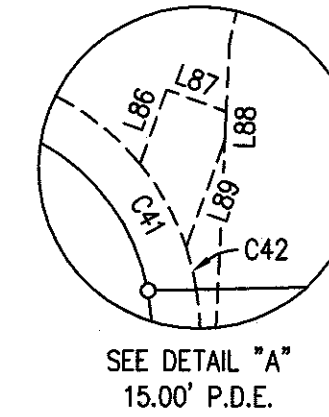
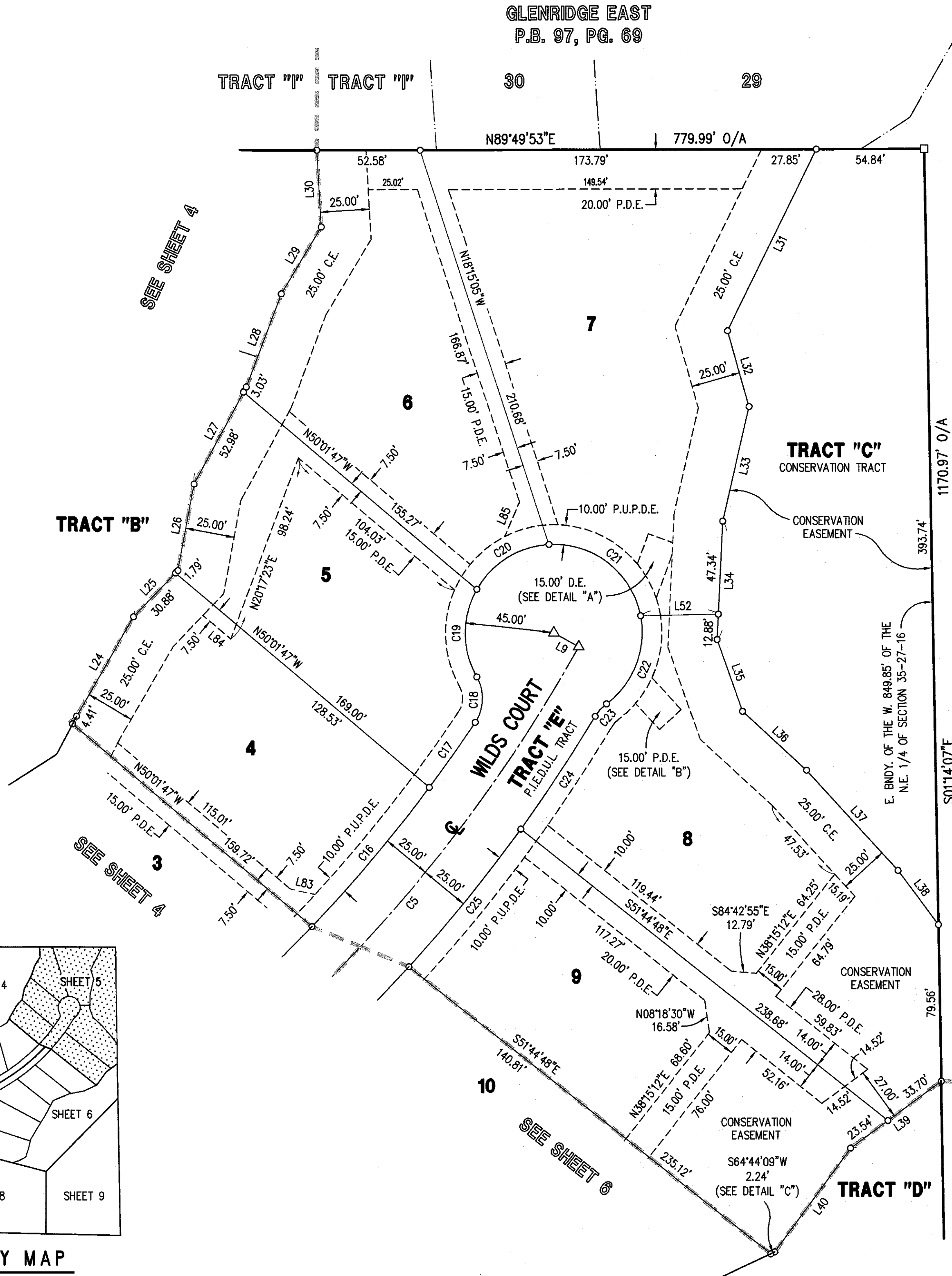

LINE DATA		
LINE	BEARING	DISTANCE
L9	S60°59'05"E	14.53'
L23	N27°36'02"E	21.89'
L24	N29°51'40"E	58.28'
L25	N43°39'06"E	32.68'
L26	N10°22'22"E	44.67'
L27	N28°15'21"E	56.01'
L28	N20°24'28"E	50.54'
L29	N30°48'09"E	39.54'
L30	N03°29'36"W	39.01'
L31	S25°59'49"W	102.52'
L32	S16°06'24"E	40.07'
L33	S12°52'30"W	59.63'
L34	S02°30'30"W	60.22'
L35	S19°43'23"E	38.74'
L36	S47°33'13"E	44.26'
L37	S42°35'01"E	68.98'
L38	S36°59'47"E	34.34'
L39	S53°34'22"W	57.25'
L40	S36°01'18"W	65.34'
L52	N88°45'53"E	39.67'
L83	N77°32'24"W	12.93'
L84	N50°01'47"W	18.59'
L85	N22°50'07"E	19.07'
L86	N19°57'26"E	16.28'
L87	S70°02'34"E	13.21'
L88	S02°30'30"W	5.96'
L89	S19°57'26"W	23.58'
L90	S42°38'40"E	22.00'
L91	S47°21'20"W	15.00'
L92	N42°38'40"W	18.04'

CURVE TABLE					
CURVE	RADIUS	ARC	CHORD	CHORD BEARING	DELTA
C5	783.72'	482.01'	474.45'	N46°38'04"E	3574'19"
C16	758.72'	92.56'	92.50'	N40°01'37"E	6°59'22"
C17	758.72'	40.46'	40.45'	N35°00'16"E	3°03'19"
C18	22.00'	24.29'	23.08'	N01°50'42"E	63°15'49"
C19	45.00'	48.57'	44.52'	N00°08'30"W	59°17'25"
C20	45.00'	44.84'	43.01'	N58°03'04"E	57°05'43"
C21	45.00'	64.63'	59.22'	S52°15'27"E	82°17'17"
C22	45.00'	50.59'	47.97'	N21°05'43"E	64°25'02"
C23	22.00'	8.60'	8.54'	N42°06'36"E	22°23'15"
C24	808.72'	68.55'	68.53'	N33°20'41"E	4°51'25"
C25	808.72'	90.05'	90.01'	N38°57'48"E	6°22'48"
C41	55.00'	19.95'	19.84'	N29°10'02"W	20°46'46"
C42	55.00'	9.09'	9.08'	N14°02'26"W	9°28'24"
C43	55.00'	32.40'	31.94'	N07°34'29"E	33°45'27"
C44	55.00'	15.57'	15.51'	N32°33'41"E	16°12'57"

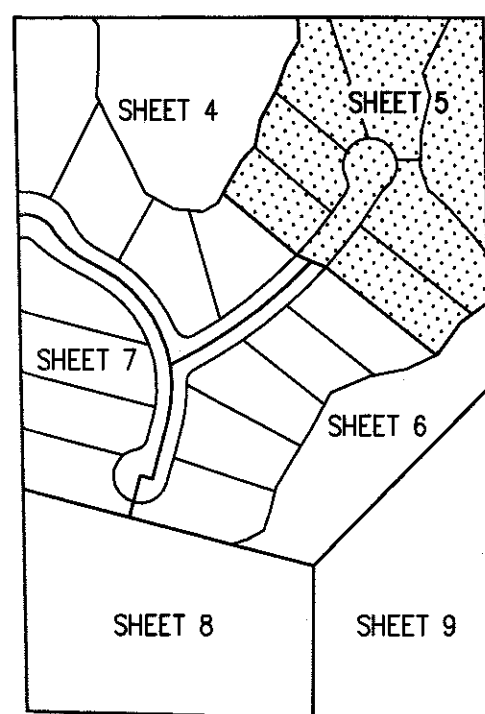

KEY MAP  
(NOT TO SCALE)

**GEORGE A SHIMP II**  
and ASSOCIATES, INC.  
LAND SURVEYING and PLANNING  
3301 DeSOTO BOULEVARD, SUITE D  
PALM HARBOR, FLORIDA 34683  
PHONE (727) 784-5496 FAX (727) 786-1256  
R.L.S. No. 2512 LB. No. 1834

# WILDS

BEING A PORTION OF THE NORTHEAST 1/4 OF SECTION 35, TOWNSHIP 27 SOUTH, RANGE 16 EAST, PINELLAS COUNTY, FLORIDA

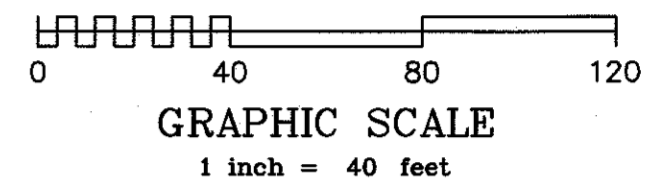
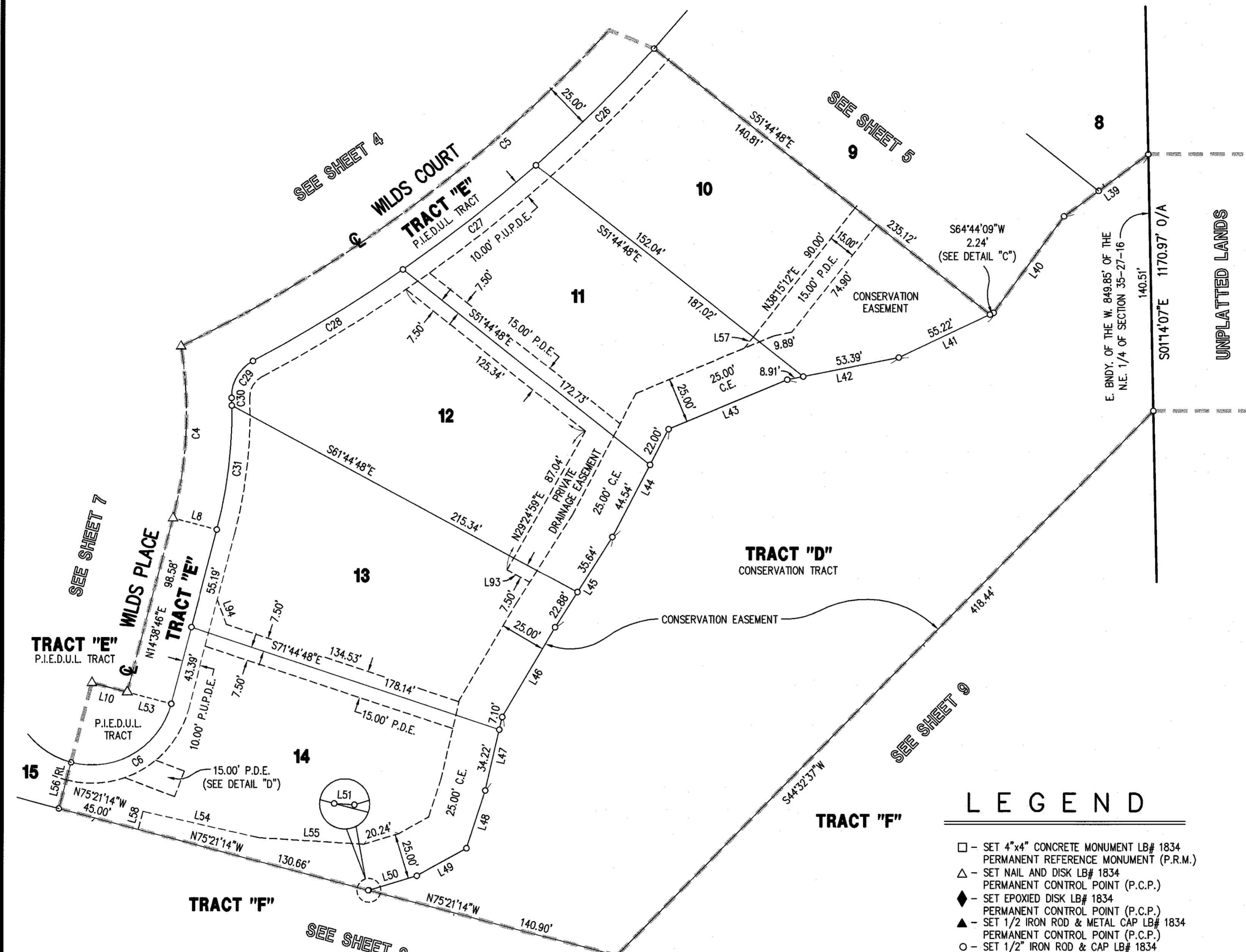

LINE DATA		
LINE	BEARING	DISTANCE
L8	S75°21'14"E	25.00'
L10	S75°21'14"E	20.00'
L39	S53°34'22"W	57.25'
L40	S36°01'18"W	65.34'
L41	S64°44'09"W	57.46'
L42	S78°47'52"W	62.30'
L43	S67°24'44"W	70.56'
L44	S27°32'03"W	66.54'
L45	S32°19'29"W	58.52'
L46	S30°21'57"W	56.81'
L47	S12°55'00"W	41.32'
L48	S17°57'15"W	33.26'
L49	S60°51'03"W	31.14'
L50	S73°04'29"W	27.41'
L51	N86°31'44"W	0.41'
L53	S75°21'14"E	25.00'
L54	S77°25'25"E	65.43'
L55	S86°31'44"E	57.51'
L56	N14°38'46"E	26.20'
L57	N38°15'12"E	7.77'
L58	N14°38'46"E	10.23'
L93	S61°44'48"E	14.14'
L94	S20°11'03"E	14.42'
L95	S69°15'33"E	16.76'
L96	S20°44'27"W	15.00'
L97	N69°15'33"W	29.26'

## LEGEND

- - SET 4"x4" CONCRETE MONUMENT LB# 1834 PERMANENT REFERENCE MONUMENT (P.R.M.)
- △ - SET NAIL AND DISK LB# 1834 PERMANENT CONTROL POINT (P.C.P.)
- ◆ - SET EPOXIED DISK LB# 1834 PERMANENT CONTROL POINT (P.C.P.)
- ▲ - SET 1/2" IRON ROD & METAL CAP LB# 1834 PERMANENT CONTROL POINT (P.C.P.)
- - SET 1/2" IRON ROD & CAP LB# 1834 LOT CORNER
- - WETLAND POINT
- BNDY. - BOUNDARY
- ⊕ - CENTERLINE
- C.C.R. - CERTIFIED CORNER RECORD
- C.E. - CONSERVATION EASEMENT
- P.D.E. - PRIVATE DRAINAGE EASEMENT
- ESM'T - EASEMENT
- F.C.M. - FOUND CONCRETE MONUMENT
- INC. - INCORPORATED
- L.B. - LAND SURVEYING BUSINESS
- NO. - NUMBER
- O.R.B. - OFFICIAL RECORDS BOOK
- P.B. - PLAT BOOK
- PG(S) - PAGE(S)
- P.I.E.D.U.L. - PRIVATE INGRESS, EGRESS, DRAINAGE, UTILITY AND LANDSCAPE
- P.O.B. - POINT OF BEGINNING
- P.O.C. - POINT OF COMMENCEMENT
- P.U.P.D.E. - PUBLIC UTILITY & PRIVATE DRAINAGE EASEMENT
- P.U.E. - PUBLIC UTILITY EASEMENT
- R.L.S. - REGISTERED LAND SURVEYOR
- R/W - RIGHT-OF-WAY
- RL - RADIAL LINE

CURVE TABLE					
CURVE	RADIUS	ARC	CHORD	CHORD BEARING	DELTA
C4	225.00'	94.85'	94.15'	N02°34'09"E	24°09'14"
C5	783.72'	482.01'	474.45'	N46°38'04"E	35°14'19"
C6	45.00'	70.69'	63.64'	N59°38'46"E	90°00'00"
C26	808.72'	90.75'	90.70'	N45°22'04"E	6°25'45"
C27	808.72'	92.65'	92.60'	N51°51'52"E	6°33'51"
C28	808.72'	96.35'	96.29'	N58°33'34"E	6°49'34"
C29	22.00'	24.59'	23.33'	N29°57'18"E	64°02'06"
C30	250.00'	4.19'	4.19'	N01°34'57"W	0°57'36"
C31	250.00'	68.72'	68.50'	N06°46'19"E	15°44'55"
C45	55.00'	19.63'	19.52'	N60°32'10"E	20°26'45"
C46	55.00'	32.53'	32.06'	N87°42'09"E	33°53'13"

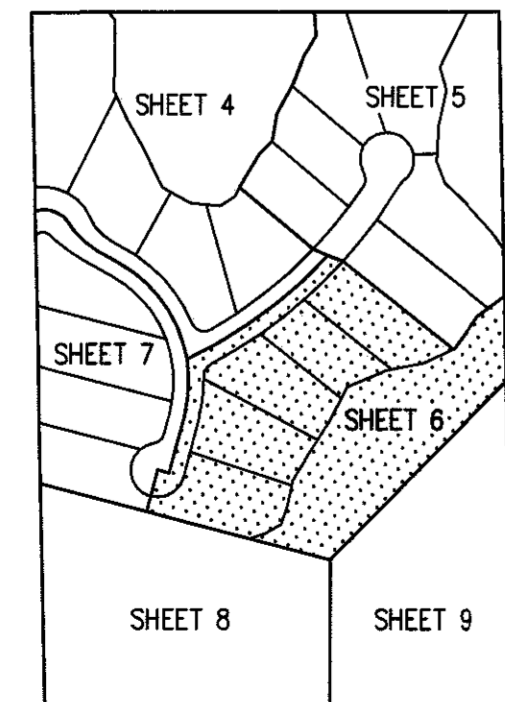

KEY MAP  
(NOT TO SCALE)

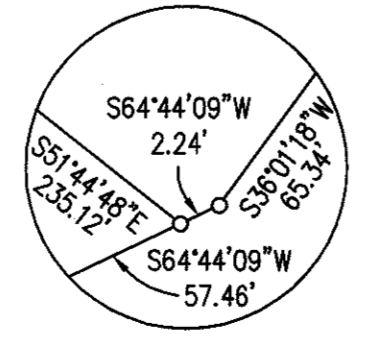

SEE DETAIL "C"  
LOT LINE

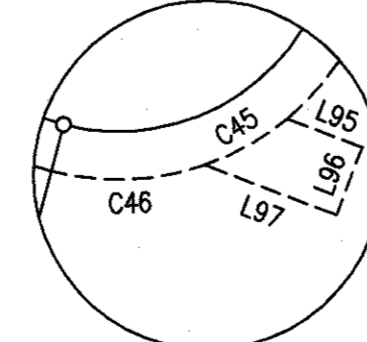

SEE DETAIL "D"  
15.00' P.D.E.

**GEORGE A SHIMP II**  
and ASSOCIATES, INC.  
LAND SURVEYING and PLANNING  
3301 DeSOTO BOULEVARD, SUITE D  
PALM HARBOR, FLORIDA 34683  
PHONE (727) 784-5490 FAX (727) 786-1256  
R.L.S. No. 2512 L.B. No. 1834

# WILDS

BEING A PORTION OF THE NORTHEAST 1/4 OF SECTION 35, TOWNSHIP 27 SOUTH, RANGE 16 EAST, PINELLAS COUNTY, FLORIDA

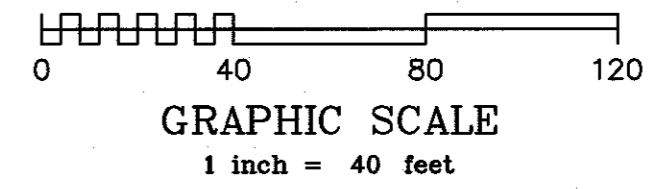
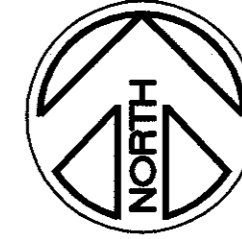

SEE SHEET 6 FOR LEGEND

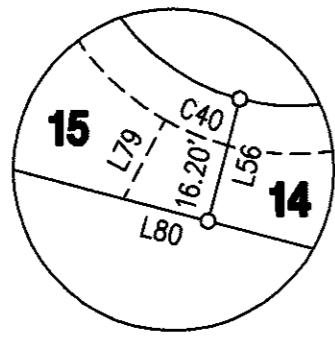

SEE DETAIL "E" PRIVATE DRAINAGE EASEMENT

LINE DATA		
LINE	BEARING	DISTANCE
L1	N35°03'27"W	15.09'
L2	N61°01'33"W	43.42'
L3	N55°06'01"E	34.18'
L5	N28°58'27"E	25.00'
L7	S75°21'14"E	25.00'
L10	S75°21'14"E	20.00'
L12	N61°01'33"W	58.99'
L13	N47°17'09"W	15.34'
L56	N14°38'46"E	26.20'
L79	N27°36'09"E	18.47'
L80	N75°21'14"W	18.09'

CURVE TABLE					
CURVE	RADIUS	ARC	CHORD	CHORD BEARING	DELTA
C1	47.66'	61.20'	57.08'	N71°50'47"W	73°34'40"
C2	116.72'	52.90'	52.45'	N48°02'30"W	25°58'06"
C3	225.00'	202.31'	195.56'	N35°16'01"W	51°31'05"
C4	225.00'	94.85'	94.15'	N02°34'09"E	24°09'14"
C32	200.00'	17.74'	17.73'	N12°06'19"E	5°04'54"
C33	200.00'	105.05'	103.84'	N05°28'56"W	30°05'36"
C34	200.00'	141.36'	138.44'	N40°46'38"W	40°29'49"
C35	213.00'	51.08'	50.96'	N54°09'21"W	13°44'24"
C36	16.00'	25.31'	22.75'	S87°23'53"W	90°37'55"
C37	45.00'	98.77'	80.10'	N12°28'32"W	125°45'24"
C38	45.00'	23.94'	23.66'	N65°38'31"E	30°28'42"
C39	22.00'	25.43'	24.04'	N47°45'49"E	66°14'06"
C40	55.00'	14.10'	14.06'	S68°00'33"E	14°41'23"

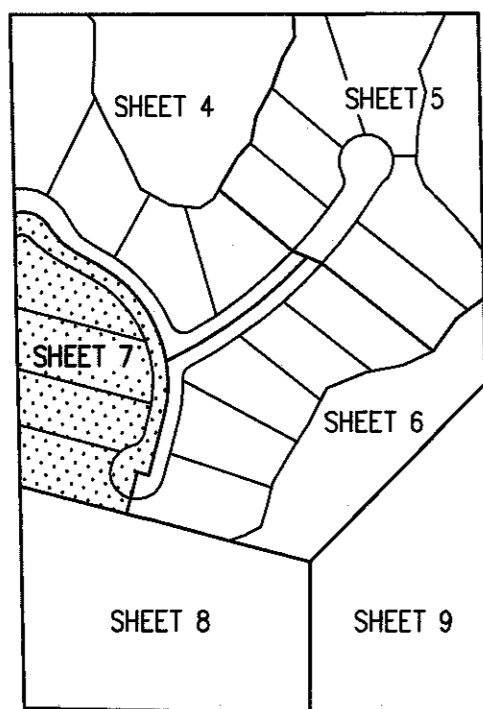

KEY MAP  
(NOT TO SCALE)

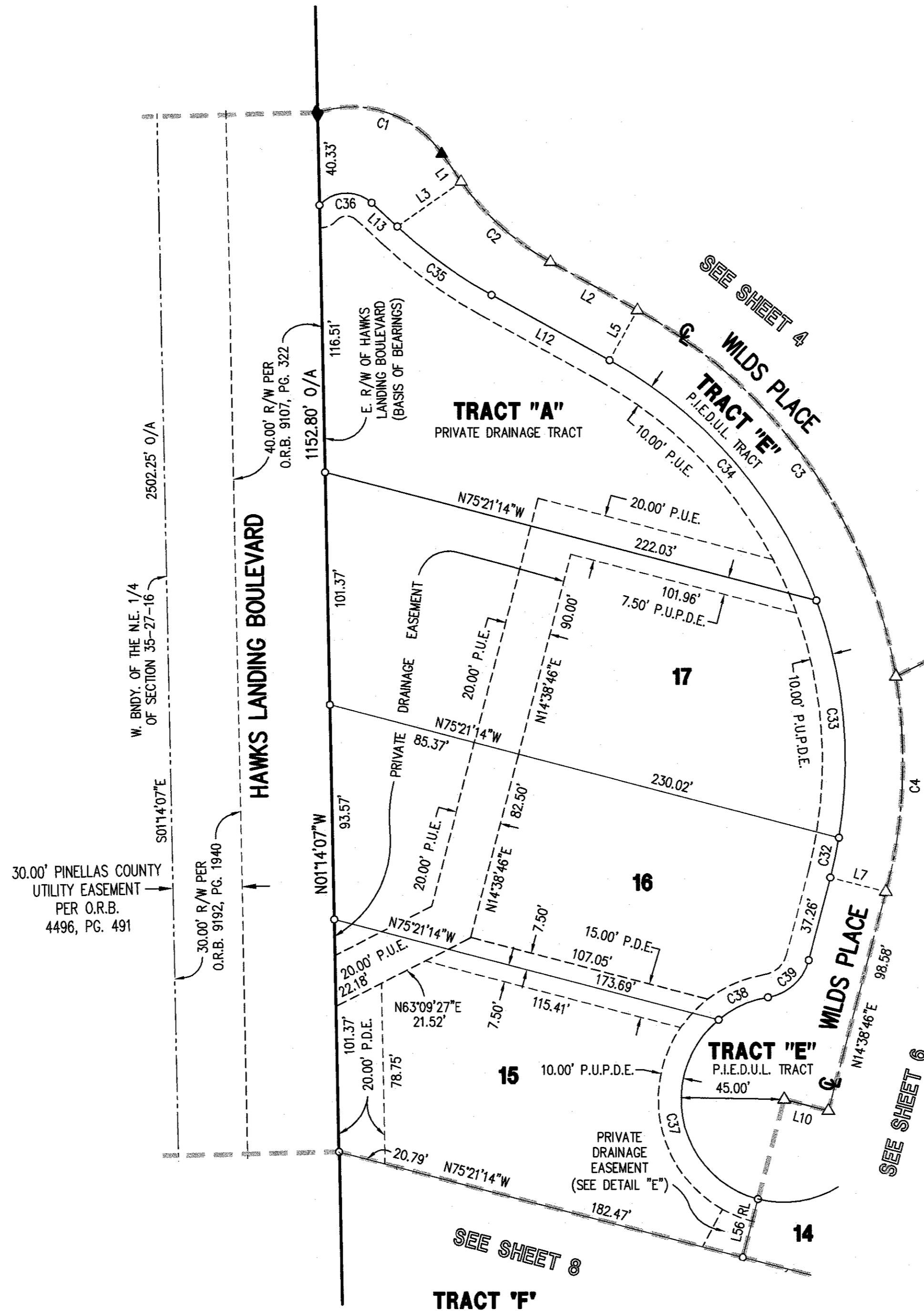

**GEORGE A SHIMP II**  
and ASSOCIATES, INC.  
LAND SURVEYING and PLANNING  
3301 DeSOTO BOULEVARD, SUITE D  
PALM HARBOR, FLORIDA 34683  
PHONE (727) 784-5496 FAX (727) 786-1256  
R.L.S. No. 2512 L.B. No. 1834



# WILDS

BEING A PORTION OF THE NORTHEAST 1/4 OF SECTION 35, TOWNSHIP 27 SOUTH, RANGE 16 EAST, PINELLAS COUNTY, FLORIDA

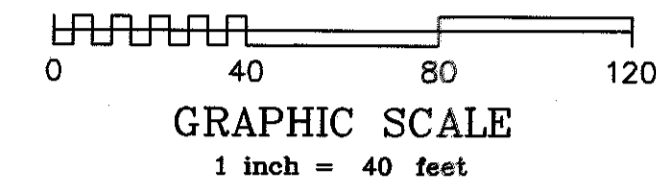
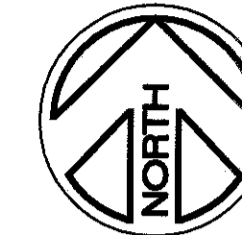

SEE SHEET 6 FOR LEGEND

LINE DATA		
LINE	BEARING	DISTANCE
L59	N40°40'32"E	25.39'
L60	N03°37'17"E	50.97'
L61	N22°24'04"E	60.33'
L62	N61°16'41"E	66.79'
L63	N41°53'24"E	38.82'
L64	N14°10'26"W	40.21'
L65	N14°25'25"W	50.28'
L66	S85°27'41"E	32.65'
L67	S80°46'25"E	24.56'
L68	S23°17'43"E	88.56'
L69	S48°41'56"E	41.38'
L70	S73°51'49"E	63.73'
L71	S69°58'45"E	57.32'
L74	N01°14'07"W	27.81'
L75	N41°07'14"W	62.58'
L76	N33°46'38"E	19.27'
L77	N07°01'06"E	8.59'
L78	S41°07'14"E	82.41'

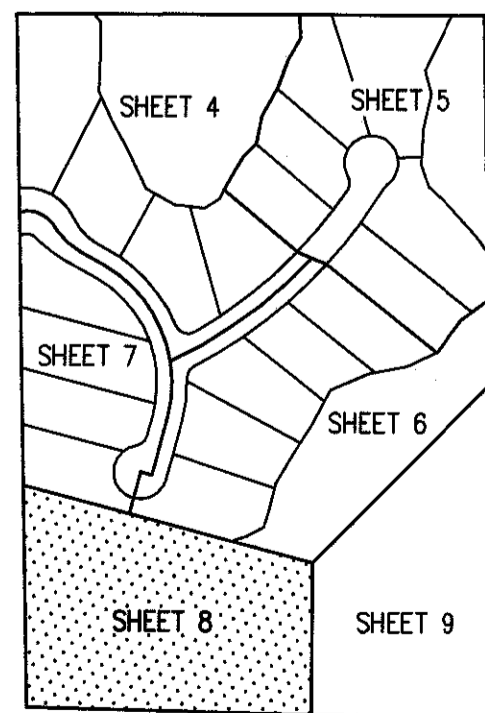
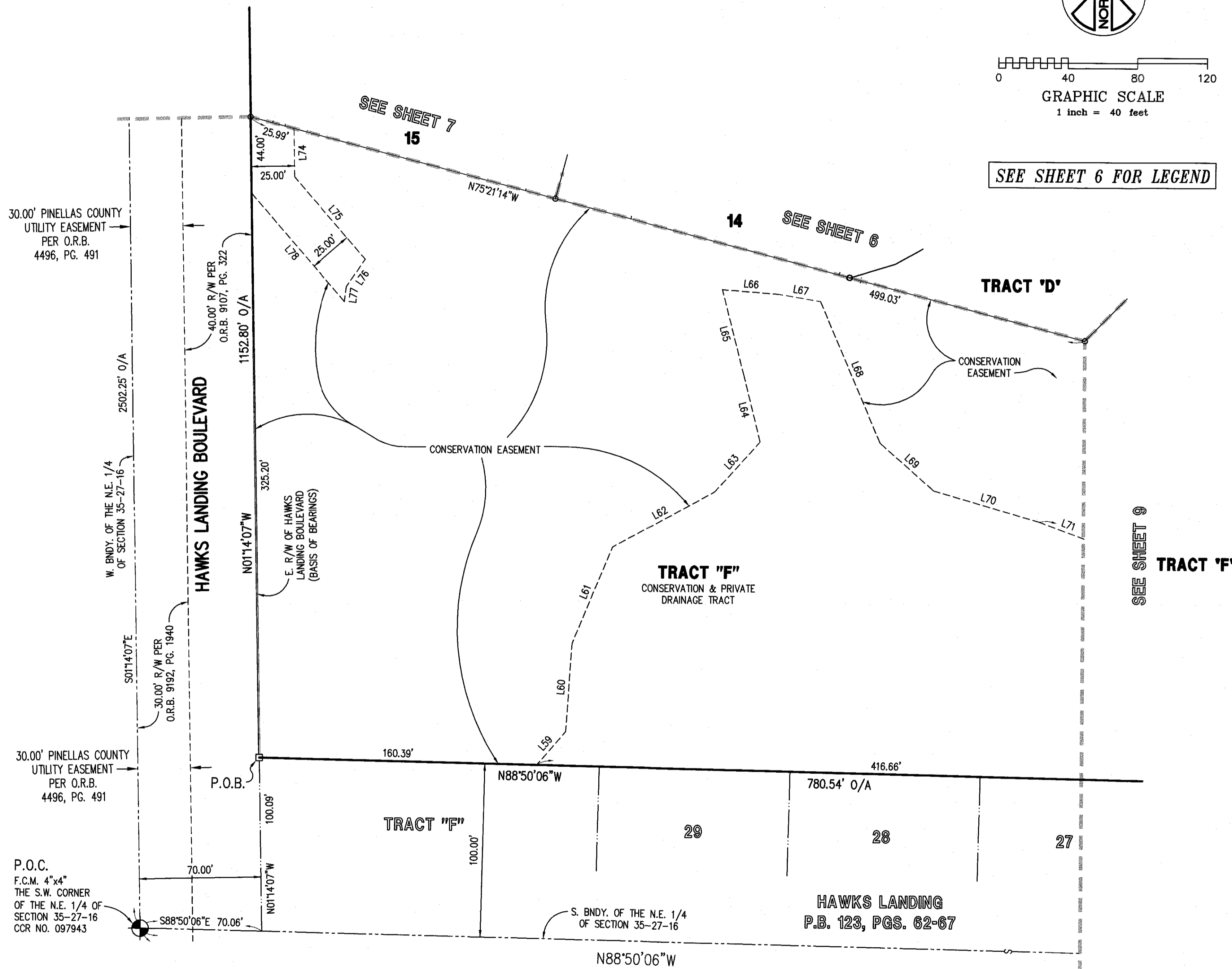

KEY MAP  
(NOT TO SCALE)

**GEORGE A SHIMP II**  
and ASSOCIATES, INC.  
LAND SURVEYING and PLANNING  
3301 DeSOTO BOULEVARD, SUITE D  
PALM HARBOR, FLORIDA 34683  
PHONE (727) 784-5496 FAX (727) 786-1256  
R.L.S. No. 2512 L.B. No. 1834



# WILDS

BEING A PORTION OF THE NORTHEAST 1/4 OF SECTION 35, TOWNSHIP 27 SOUTH, RANGE 16 EAST, PINELLAS COUNTY, FLORIDA

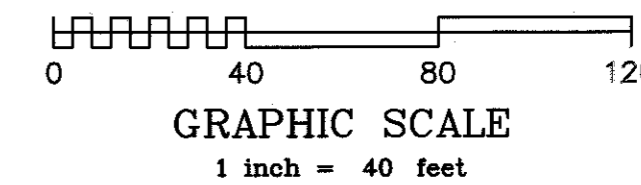
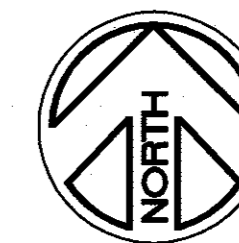

SEE SHEET 6 FOR LEGEND

LINE DATA		
LINE	BEARING	DISTANCE
L71	S69°58'45"E	57.32'
L72	S49°49'18"E	98.29'
L73	S01°09'54"W	67.14'

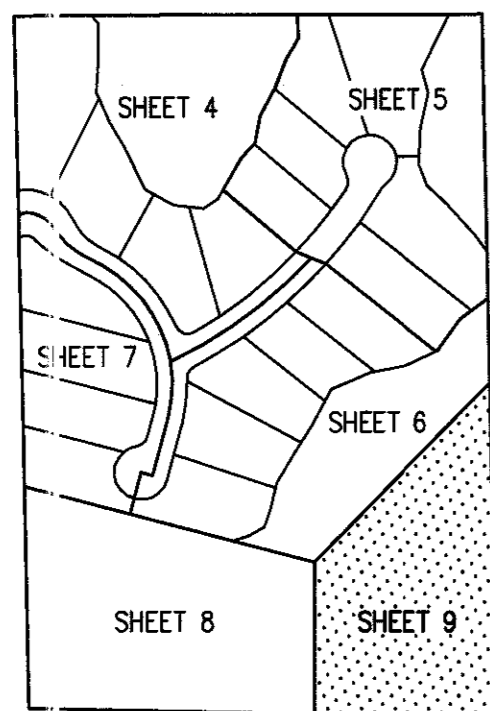

KEY MAP  
(NOT TO SCALE)

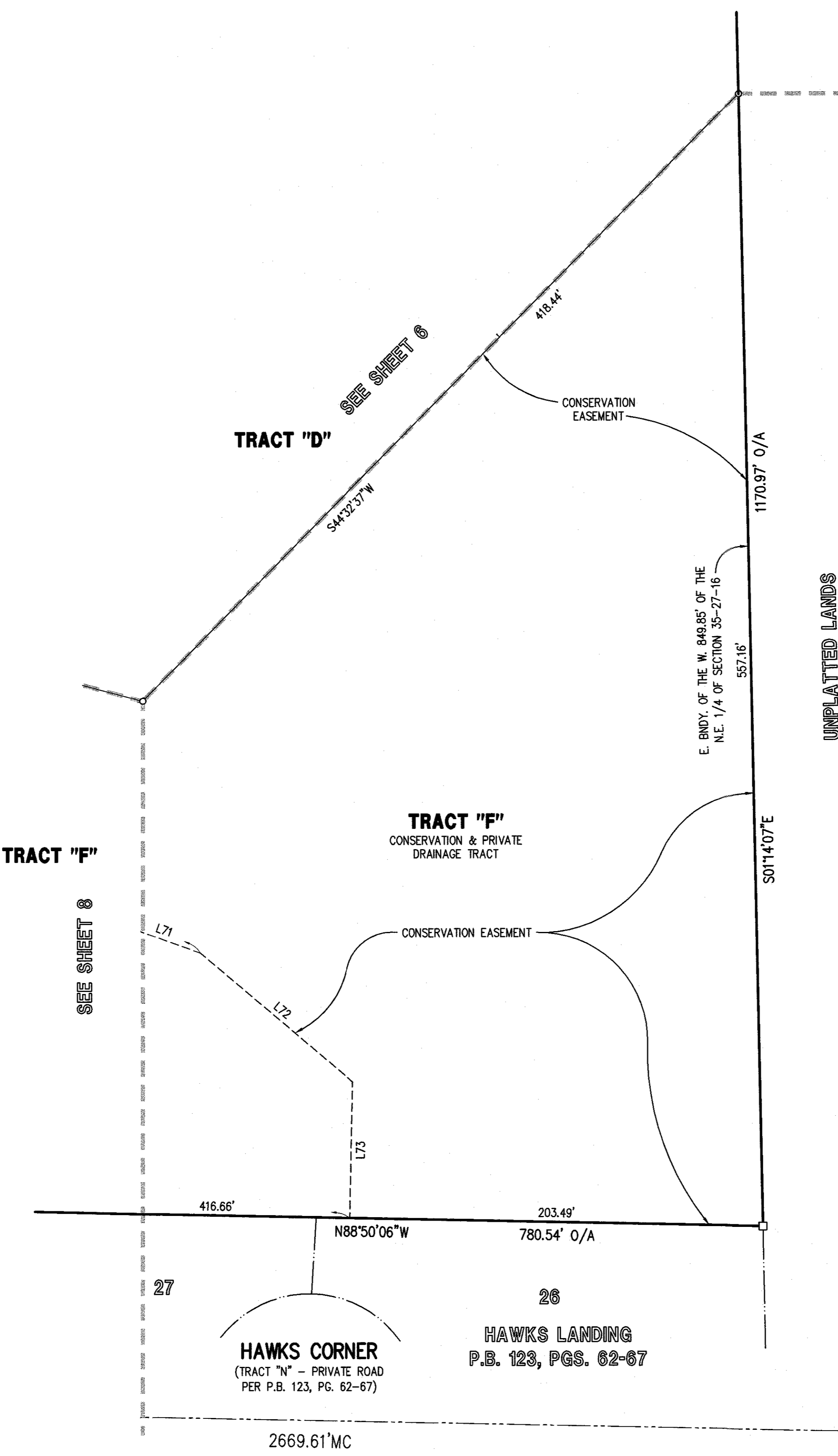

THIS PROPERTY MAY BE SUBJECT TO THOSE DOCUMENTS AS RECORDED IN THE PUBLIC RECORDS OF PINELLAS COUNTY, FLORIDA AS DESCRIBED BELOW:

- 1.) UTILITY EASEMENT GRANTED TO PINELLAS COUNTY, RECORDED IN O.R.B. 4496, PG. 491
- 2.) MEMORANDUM OF AGREEMENT AS CONTAINED IN WARRANTY DEED RECORDED IN O.R.B. 4141, PG. 858, AS AMENDED BY AMENDMENT TO MEMORANDUM OF AGREEMENT AND AGREEMENT RECORDED IN O.R.B. 5450, PG. 1483
- 3.) AGREEMENT RECORDED IN O.R.B. 4831, PG. 351
- 4.) ASSIGNMENT RECORDED IN O.R.B. 18545, PG. 1849
- 5.) NON-EXCLUSIVE TEMPORARY EASEMENT RECORDED IN O.R.B. 19842, PG. 1656
- 6.) CONSTRUCTION EASEMENT AS DESCRIBED IN WARRANTY DEED RECORDED IN O.R.B. 18545, PG. 1830
- 7.) NON-EXCLUSIVE RECIPROCAL EASEMENT FOR ACCESS, DRAINAGE & UTILITIES RECORDED IN O.R.B. 19835, PG. 1663
- 8.) DECLARATION OF COVENANTS, CONDITIONS AND RESTRICTIONS FOR THE WILDS, RECORDED IN O.R.B. 19842, PG. 1548
- 9.) FIRST AMENDMENT TO DECLARATION OF COVENANTS, CONDITIONS AND RESTRICTIONS FOR THE WILDS, RECORDED IN O.R.B. 20038, PG. 2522
- 10.) WATER AREA AND SUPPLY AGREEMENT RECORDED IN O.R.B. 5564, PG. 1820 AND IN O.R.B. 5564, PG. 1834

4"x4" C.M.  
(AREA INACCESSIBLE)  
S.E. CORNER OF THE N.E.  
1/4 OF SECTION 35-27-16  
CCR NO. 049074

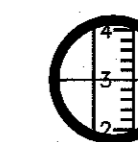

**GEORGE A SHIMP II**  
**and ASSOCIATES, INC.**

LAND SURVEYING and PLANNING  
3301 DESOTO BOULEVARD, SUITE D  
PALM HARBOR, FLORIDA 34883  
PHONE (727) 784-5496 FAX (727) 786-1256  
R.L.S. No. 2512 L.B. No. 1834