



CAPITAL ASSISTANCE FOR HURRICANE RESPONSE AND RECOVERY EFFORTS (CARE)

FY 18 Pinellas County Final Application Submission

Abstract

To mitigate risk to Bayside Health Clinic by installing Hurricane Shutters, elevating the generator, and purchasing 800mhz radios and disinfecting equipment.

Human Services Dept.

June 14, 2018

Application for Federal Assistance SF-424

OMB Approval No. 4040-0004
Expiration Date 8/31/2016

* 1. Type of Submission <input type="checkbox"/> Preapplication <input checked="" type="checkbox"/> Application <input type="checkbox"/> Changed/Corrected Application		* 2. Type of Application <input checked="" type="checkbox"/> New <input type="checkbox"/> Continuation <input type="checkbox"/> Revision		* If Revision, select appropriate letter(s): <input type="text"/> * Other (Specify) <input type="text"/>
--	--	--	--	---

* 3. Date Received: <input type="text"/>	4. Applicant Identifier: <input type="text"/>
--	---

* 5.a Federal Entity Identifier: Application #: 155688 Grants.Gov #: <input type="text"/>	5.b Federal Award Identifier: <input type="text"/>
--	--

* 6. Date Received by State: <input type="text"/>	7. State Application Identifier: <input type="text"/>
---	---

8. Applicant Information:	
* a. Legal Name * b. Employer/Taxpayer Identification Number (EIN/TIN): 59-6000800	PINELLAS, COUNTY OF * c. Organizational DUNS: 055200216
d. Address:	
* Street1:	14 S. Fort Harrison OMB 5th Floor
Street2:	
* City:	CLEARWATER
County:	
* State:	FL
Province:	
* Country:	US: United States
* Zip / Postal Code:	33756-5338

e. Organization Unit:	
Department Name:	Division Name:
<input type="text"/>	<input type="text"/>

f. Name and contact information of person to be contacted on matters involving this application:			
Prefix:	<input type="text"/>	* First Name:	Daisy
Middle Name: Middle Name:	M		
Last Name:	Rodriguez		
Suffix:	<input type="text"/>		
Title:	<input type="text"/>		
Organizational Affiliation:	<input type="text"/>		
* Telephone Number:	(727) 464-4206	Fax Number:	<input type="text"/>
* Email:	darodriguez@pinellascounty.org		

9. Type of Applicant 1: B: County Government	
Type of Applicant 2:	
Type of Applicant 3:	
* Other (specify):	
<input type="text"/>	

* 10. Name of Federal Agency: N/A

11. Catalog of Federal Domestic Assistance Number: 93.224 CFDA Title: Community Health Centers
--

* 12. Funding Opportunity Number: HRSA-18-114 * Title: FY 2018 Capital Assistance for Hurricane Response and Recovery Efforts

13. Competition Identification Number: 7498 Title: FY 2018 Capital Assistance for Hurricane Response and Recovery Efforts

Areas Affected by Project (Cities, Counties, States, etc.): See Attachment
--

* 15. Descriptive Title of Applicant's Project: FY 2018 Capital Assistance for Hurricane Response and Recovery Efforts Project Description: See Attachment
--

16. Congressional Districts Of:			
* a. Applicant	FL-13	* b. Program/Project	FL-13

Additional Program/Project Congressional Districts:
See Attachment

17. Proposed Project:

* a. Start Date: * b. End Date:

18. Estimated Funding (\$):

* a. Federal	\$107,075.00
* b. Applicant	\$0.00
* c. State	\$0.00
* d. Local	\$0.00
* e. Other	\$0.00
* f. Program Income	\$0.00
* g. TOTAL	\$107,075.00

19. Is Application Subject to Review By State Under Executive Order 12372 Process?

a. This application was made available to the State under the Executive Order 12372 Process for review on

b. Program is subject to E.O. 12372 but has not been selected by the State for review.

c. Program is not covered by E.O. 12372.

20. Is the Applicant Delinquent Of Any Federal Debt(If "Yes", provide explanation in attachment.)

Yes No

21. *By signing this application, I certify (1) to the statements contained in the list of certifications** and (2) that the statements herein are true, complete and accurate to the best of my knowledge. I also provide the required assurances** and agree to comply with any resulting terms if I accept an award. I am aware that any false, fictitious, or fraudulent statements or claims may subject me to criminal, civil, or administrative penalties. (U.S. Code, Title 218, Section 1001)

I Agree

** The list of certifications and assurances, or an internet site where you may obtain this list, is contained in the announcement or agency specific instructions.

Authorized Representative:

Prefix:	<input type="text"/>	* First Name:	<input type="text" value="Daisy"/>
Middle Name:	<input type="text" value="M"/>		
* Last Name:	<input type="text" value="Rodriguez"/>		
Suffix:	<input type="text"/>		
* Title:	<input type="text"/>		
* Telephone Number:	<input type="text" value="(727) 464-4206"/>	Fax Number:	<input type="text"/>
* Email:	<input type="text" value="darodriguez@pinellascounty.org"/>		
* Signature of Authorized Representative:	<input type="text" value="Daisy M Rodriguez"/>	* Date Signed:	<input type="text"/>

SF-424A: BUDGET INFORMATION - Non-Construction Programs

OMB Approval No. 4040-0004

Expiration Date 8/31/2016

SECTION A - BUDGET SUMMARY						
Grant Program Function or Activity	Catalog of Federal Domestic Assistance Number	Estimated Unobligated Funds		New or Revised Budget		
		Federal	Non-Federal	Federal	Non-Federal	Total
FY 2018 Capital Assistance for Hurricane Response and Recovery Efforts	93.224	\$0.00	\$0.00	\$107,075.00	\$0.00	\$107,075.00
Total		\$0.00	\$0.00	\$107,075.00	\$0.00	\$107,075.00

SECTION C - NON-FEDERAL RESOURCES				
Grant Program Function or Activity	Applicant	State	Other Sources	TOTALS
FY 2018 Capital Assistance for Hurricane Response and Recovery Efforts	\$0.00	\$0.00	\$0.00	\$0.00
Total	\$0.00	\$0.00	\$0.00	\$0.00

SF-424B: ASSURANCES, NON-CONSTRUCTION PROGRAMS

OMB Approval No. 4040-0007
 Expiration Date 06/30/2014

Public reporting burden for this collection of information is estimated to average 15 minutes per response, including time for reviewing instructions, searching existing data sources, gathering and maintaining the data needed, and completing and reviewing the collection of information. Send comments regarding the burden estimate or any other aspect of this collection of information, including suggestions for reducing this burden, to the Office of Management and Budget, Paperwork Reduction Project (0348-0040), Washington, DC 20503.

PLEASE DO NOT RETURN YOUR COMPLETED FORM TO THE OFFICE OF MANAGEMENT AND BUDGET. SEND IT TO THE ADDRESS PROVIDED BY THE SPONSORING AGENCY.

NOTE: Certain of these assurances may not be applicable to your project or program. If you have questions, please contact the awarding agency. Further, certain Federal awarding agencies may require applicants to certify to additional assurances. If such is the case, you will be notified.

As the duly authorized representative of the applicant, I certify that the applicant:

1. Has the legal authority to apply for Federal assistance and the institutional, managerial and financial capability (including funds sufficient to pay the non-Federal share of project cost) to ensure proper planning, management and completion of the project described in this application.
2. Will give the awarding agency, the Comptroller General of the United States and, if appropriate, the State, through any authorized representative, access to and the right to examine all records, books, papers, or documents related to the award; and will establish a proper accounting system in accordance with generally accepted accounting standards or agency directives.
3. Will establish safeguards to prohibit employees from using their positions for a purpose that constitutes or presents the appearance of personal or organizational conflict of interest, or personal gain.
4. Will initiate and complete the work within the applicable time frame after receipt of approval of the awarding agency.
5. Will comply with the Intergovernmental Personnel Act of 1970 (42 U.S.C. §§4728-4763) relating to prescribed standards for merit systems for programs funded under one of the 19 statutes or regulations specified in Appendix A of OPM's Standards for a Merit System of Personnel Administration (5 C.F.R. 900, Subpart F).
6. Will comply with all Federal statutes relating to nondiscrimination. These include but are not limited to: (a) Title VI of the Civil Rights Act of 1964 (P.L. 88-352) which prohibits discrimination on the basis of race, color or national origin; (b) Title IX of the Education Amendments of 1972, as amended (20 U.S.C. §§1681- 1683, and 1685-1686), which prohibits discrimination on the basis of sex; (c) Section 504 of the Rehabilitation Act of 1973, as amended (29 U.S.C. §794), which prohibits discrimination on the basis of handicaps; (d) the Age Discrimination Act of 1975, as amended (42 U.S.C. §§6101-6107), which prohibits discrimination on the basis of age; (e) the Drug Abuse Office and Treatment Act of 1972 (P.L. 92-255), as amended, relating to nondiscrimination on the basis of drug abuse; (f) the Comprehensive Alcohol Abuse and Alcoholism Prevention, Treatment and Rehabilitation Act of 1970 (P.L. 91-616), as amended, relating to nondiscrimination on the basis of alcohol abuse or alcoholism; (g) §§523 and 527 of the Public Health Service Act of 1912 (42 U.S.C. §§290 dd-3 and 290 ee- 3), as amended, relating to confidentiality of alcohol and drug abuse patient records; (h) Title VIII of the Civil Rights Act of 1968 (42 U.S.C. §§3601 et seq.), as amended, relating to nondiscrimination in the sale, rental or financing of housing; (i) any other nondiscrimination provisions in the specific statute(s) under which application for Federal assistance is being made; and, (j) the requirements of any other nondiscrimination statute(s) which may apply to the application.
7. Will comply, or has already complied, with the requirements of Titles II and III of the Uniform Relocation Assistance and Real Property Acquisition Policies Act of 1970 (P.L. 91-646) which provide for fair and equitable treatment of persons displaced or whose property is acquired as a result of Federal or federally-assisted programs. These requirements apply to all interests in real property acquired for project purposes regardless of Federal participation in purchases.
8. Will comply, as applicable, with provisions of the Hatch Act (5 U.S.C. §§1501-1508 and 7324-7328) which limit the political activities of employees whose principal employment activities are funded in whole or in part with Federal funds.
9. Will comply, as applicable, with the provisions of the Davis-Bacon Act (40 U.S.C. §§276a to 276a-7), the Copeland Act (40 U.S.C. §276c and 18 U.S.C. §874), and the Contract Work Hours and Safety Standards Act (40 U.S.C. §§327-333), regarding labor standards for federally-assisted construction subagreements.
10. Will comply, if applicable, with flood insurance purchase requirements of Section 102(a) of the Flood Disaster Protection Act of 1973 (P.L. 93-234) which requires recipients in a special flood hazard area to participate in the program and to purchase flood insurance if the total cost of insurable construction and acquisition is \$10,000 or more.
11. Will comply with environmental standards which may be prescribed pursuant to the following: (a) institution of environmental quality control measures under the National Environmental Policy Act of 1969 (P.L. 91-190) and Executive Order (EO) 11514; (b) notification of violating facilities pursuant to EO 11738; (c) protection of wetlands pursuant to EO 11990; (d) evaluation of flood hazards in floodplains in accordance with EO 11988; (e) assurance of project consistency with the approved State management program developed under the Coastal Zone Management Act of 1972 (16 U.S.C. §§1451 et seq.); (f) conformity of Federal actions to State (Clean Air) Implementation Plans under Section 176(c) of the Clean Air Act of 1955, as amended (42 U.S.C. §§7401 et seq.); (g) protection of underground sources of drinking water under the Safe Drinking Water Act of 1974, as amended (P.L. 93-523); and, (h) protection of endangered species under the Endangered Species Act of 1973, as amended (P.L. 93-205).
12. Will comply with the Wild and Scenic Rivers Act of 1968 (16 U.S.C. §§1271 et seq.) related to protecting components or potential components of the national wild and scenic rivers system.
13. Will assist the awarding agency in assuring compliance with Section 106 of the National Historic Preservation Act of 1966, as amended (16 U.S.C. §470), EO 11593 (identification and protection of historic properties), and the Archaeological and Historic Preservation Act of 1974 (16 U.S.C. §§469a-1 et seq.).
14. Will comply with P.L. 93-348 regarding the protection of human subjects involved in research, development, and related activities supported by this award of assistance.
15. Will comply with the Laboratory Animal Welfare Act of 1966 (P.L. 89-544, as amended, 7 U.S.C. §§2131 et seq.) pertaining to the care, handling, and treatment of warm blooded animals held for research, teaching, or other activities supported by this award of assistance.
16. Will comply with the Lead-Based Paint Poisoning Prevention Act (42 U.S.C. §§4801 et seq.) which prohibits the use of lead-based paint in construction or rehabilitation of residence structures.
17. Will cause to be performed the required financial and compliance audits in accordance with the Single Audit Act Amendments of 1996 and OMB Circular No. 45 CFR 75, "Audits of States, Local Governments, and Non-Profit Organizations."
18. Will comply with all applicable requirements of all other Federal laws, executive orders, regulations, and policies governing this program.
19. Will comply with the requirements of Section 106(g) of the Trafficking Victims Protection Act (TVPA) of 2000, as amended (22 U.S.C. 7104) which prohibits grant award recipients or a sub-recipient from (1) Engaging in severe forms of trafficking in persons during the period of time that the award is in effect (2) Procuring a commercial sex act during the period of time that the award is in effect or (3) Using forced labor in the performance of the award or subawards under the award.

* SIGNATURE OF AUTHORIZED CERTIFYING OFFICIAL

Daisy M Rodriguez

* APPLICANT ORGANIZATION

PINELLAS, COUNTY OF

* TITLE

* DATE SUBMITTED

Program Specific Form(s) - Review

0015688: PINELLAS, COUNTY OF		Due Date: 06/14/2018 (Due In: 0 Days)
Announcement Number: HRSA-18-114	Announcement Name: FY 2018 Capital Assistance for Hurricane Response and Recovery Efforts	Application Type: New
Total Federal Requested Amount: \$107,075.00		
Resources ↗		

Proposal Cover Page

As of 06/14/2018 09:04:37 AM
OMB Number: 0915-0285 OMB Expiration Date: 1/31/2020

1. Applicant Eligibility
Provide the eligible H80 grant number:

H80CS00024

2. Response
a. Describe how the proposal including minor A/R activities and/or equipment purchases relate to the response and recovery needs and efforts of the health center. Your response should align with and reference more detailed project-related information in the Project Description section of the Project Cover Page(s).

Max 4000 Characters with spaces

The eye of Hurricane Irma passed about 40 miles east of Pinellas County during the early morning hours of September 11. While the county prepared and evacuated for a direct hit by a Category 2 storm, it was spared the worst impacts when it received sustained tropical storm-force winds and up to Category 1 hurricane-strength gusts with negligible storm surge. Pinellas County had not experienced a hurricane since 2004, when Hurricanes Charley, Frances, and Jeanne affected the county. Since then, hundreds of county, municipal, and private-sector organizations have spent months and years planning for the next hurricane to strike the county. Personnel from these agencies worked long hours before, during, and after the storm to communicate with the public, evacuate residents and visitors (including those with special needs), open and operate hurricane shelters for people and pets, repair infrastructure damage, and remove debris. Although Pinellas County escaped a storm surge, Hurricane Irma left behind more than \$38 million in damage to businesses, residences, and infrastructure. Over 400,000 county customers lost power, with outages lasting up to a week for some customers. However, despite the disruption of infrastructure and massive movement of people—including hospital patients—no lives were lost in Pinellas County during the storm. With over 350,000 residents within the evacuation zones, the county was successful in implementing key missions, including evacuation, sheltering, and post-storm debris removal. Forty-nine healthcare facilities evacuated 3,250 patients, and the county cared for more than 23,000 people and 2,000 pets in public shelters. Pinellas County Public Works picked up more than 375,000 cubic yards of debris and kept potable water flowing throughout the storm and the days that followed. The hurricane provided an opportunity to test plans, identify refinements to those plans, and prepare for future hurricanes that could be much more devastating than Hurricane Irma. Challenges included communications and technology outages, sheltering individuals with special needs, monitoring the status of healthcare facilities, and illegal dumping. While the Pinellas County Health Care for the Homeless Program was closed just prior to and in the immediate aftermath of the storm, the health center has identified a few areas of improvement to ensure that the health center sites and staff's ability to operate for as long as possible leading up to and re-open as soon thereafter a storm are improved. The CARE project will include alteration/renovation improvements and non-clinical equipment that will also benefit the program during other hazard-related events identified by the organization. The alteration/renovation project includes two items: 1) raising up the generator higher above ground to reduce the risk of damage due to flooding; and 2) adding hurricane shutters to the health center site windows. Non-clinical equipment included in this proposal includes the purchase of 800 MHz radios that will enable health center staff to communicate with emergency management personnel and leadership; and disinfecting/sanitizing sprayer equipment to quickly reduce any risk to patients following an outbreak or any unsanitary condition that may arise following an event.

b. Describe any circumstances, if applicable, where the health center intends to use CARE funding at sites that are not within the FEMA designated disaster areas (See Appendix D). Please detail the circumstances that necessitate the CARE funding be used at site(s) not specifically impacted by the hurricanes.
--

Max 4000 Characters with spaces

Pinellas County does not intent to use CARE funding at sites not within the FEMA designated area.

Assurances

As of 06/14/2018 09:04:37 AM
OMB Number: 0915-0285 OMB Expiration Date: 1/31/2020

Assurances (Minimum 1) (Maximum 1)				
Document Name	Size	Date Attached	Description	Uploaded By
ConstructionAssurancesSF424D_Signed.pdf	68 kB	06/14/2018	Assurances SF424D - Signed	Elisa DeGregorio

Consolidated Budget

As of 06/14/2018 09:04:37 AM
OMB Number: 0915-0285 OMB Expiration Date: 1/31/2020

Serial Number	Cost Classification	Total Cost (a)	Costs Not Allowable for Participation (b)	Total Allowable Costs (c = a - b)
1	Administrative and legal expenses	\$25,000.00	\$0.00	\$25,000.00
2	Land, structures, rights-of-way, appraisals, etc.	\$0.00	\$0.00	\$0.00
3	Relocation expenses and payments	\$0.00	\$0.00	\$0.00
4	Architectural and engineering fees	\$10,000.00	\$0.00	\$10,000.00
5	Other architectural and engineering fees	\$0.00	\$0.00	\$0.00
6	Project inspection fees	\$5,000.00	\$0.00	\$5,000.00

7	Site work	\$2,500.00	\$0.00	\$2,500.00
8	Demolition and removal	\$0.00	\$0.00	\$0.00
9	Construction	\$45,000.00	\$0.00	\$45,000.00
10	Equipment	\$17,200.00	\$0.00	\$17,200.00
11	Miscellaneous	\$0.00	\$0.00	\$0.00
12	SUBTOTAL (sum of lines 1-11)	\$104,700.00	\$0.00	\$104,700.00
13	Contingencies	\$2,375.00	\$0.00	\$2,375.00
14	SUBTOTAL (sum of lines 12 and 13)	\$107,075.00	\$0.00	\$107,075.00
15	Project (program) income	\$0.00	\$0.00	\$0.00
16	TOTAL PROJECT COSTS	\$107,075.00	\$0.00	\$107,075.00
17	Federal assistance requested Federal Percentage Share : 100.00 %			\$107,075.00

Project Qualification Criteria

As of 06/14/2018 09:04:37 AM
OMB Number: 0915-0285 OMB Expiration Date: 1/31/2020

Project Information							
Project Title	Bayside Health Clinic - Hurricane Risk Mitigation	Project Type	Alteration / Renovation (A/R)	Project Tracking Number	155688-02	Amount requested in this project	\$107,075.00

1. No (e.g., installation of utilities, demolition, renovation, etc.) physical alterations and renovations will occur until after a grant award has been made and all conditions have been met and lifted from the Notice of Award. If no, explain.

Yes No
If 'No,' provide the description.

2. If the proposed project is on leased property, has the landlord consented in writing to all proposed improvements, and agreed to all federal requirements, including Federal Interest?

Yes No
If 'No,' provide the description.

The property is owned by Pinellas County, therefore no landlord consent is needed. Pinellas County agrees to all federal requirements, including Federal Interest.

Certification	
<input checked="" type="checkbox"/> I certify that the above statements are accurate and true.	

Project Cover Page

As of 06/14/2018 09:04:37 AM
OMB Number: 0915-0285 OMB Expiration Date: 1/31/2020

Project Information							
Project Title	Bayside Health Clinic - Hurricane Risk Mitigation	Project Type	Alteration / Renovation (A/R)	Project Tracking Number	155688-02	Amount requested in this project	\$107,075.00

1. Site Information

Improved Project Square Footage: 3000

2. Project Description

Provide a detailed description of the scope of work (all project components) involved in the project. Indicate where the project involves the construction of new facilities, or the renovation of existing ones. Describe each of the project components in terms of dimensions, quantities, capacities, square footage, etc. Identify the proposed method of construction. Describe how the major clinical and non-clinical spaces will be improved from the project. The description should also list major improvements, such as permanently affixed equipment to be installed; modifications and repairs to the building exterior (including windows); heating, ventilation and air conditioning (HVAC) modifications (including the installation of climate control and duct work); electrical upgrades; and plumbing work. Indicate whether construction procurement shall be done through competitive bid or other method. Indicate if any portion of the project is to be done by design/build, construction management at risk, by the applicant's own forces, or whether a third party construction manager will be used.

Approximately 2 pages (Max 4000 Characters with spaces) Pinellas County is proposing to utilize CARE funding to enhance the Bayside Health Clinic site with two projects: 1) Raising up the generator higher above ground level to reduce damage in a flooding situation; and 2) Adding hurricane shutters to the existing exterior windows of the clinic. The Bayside Health Clinic, located at 14808 49th Street North, Clearwater, FL is in a "Level B" hurricane evacuation zone, borderline A actually. The estimated elevation is 12 ft above sea level. This means that it will likely flood in a Cat 2 hurricane. Hurricane Irma was predicted to be a Category 2 storm upon impacting west central Florida in 2017. While the

county prepared and evacuated for a direct hit by a Category 2 storm, it was spared the worst impacts when it received sustained tropical storm-force winds and up to Category 1 hurricane-strength gusts with negligible storm surge. Since each storm brings a new set of hazards and circumstances, the health center is proposing to raise up its existing generator on site at the facility to potentially reduce the risk of damage following any flooding from any weather-related event that may produce flooding. The County will also purchase 800 MHz radios for use by health center staff in any type of emergency. Finally, the County is also looking to procure two Clorox Total 360 Sanitizing machines for use in the clinic following a damaging weather related; or other hazard event such as an infectious disease outbreak.

3. Project Management

3a. Identify the individual who will be responsible for managing this project.

Project Manager	
Last Name	Rodriguez
First Name	Daisy
Middle Initial	
Phone Number	727 464 4206
Email	
Street Address Line 1	440 Court Street, 2nd fl
Street Address Line 2	
City	Clearwater
Urbanization (Used only for Puerto Rico)	
State	FL
Zip Code	33756

3b. Explain the administrative structure and oversight for the project, including the roles and responsibilities of the health center's key management staff as well as oversight by the governing board. Identify the individual who will be the Project Manager and the individuals who comprise the Project Team responsible for managing the project. Indicate the qualifications of the Project Manager who will be responsible for managing the project and the Project Team that will be implementing the project. Describe how the Project Team has the expertise and experience necessary to successfully manage a federally supported capital project within the timeline outlined and achieve the goals and objectives established for this project. Describe the Project Team's ability to manage risk and take corrective action as necessary.

Approximately 1 page (Max 2000 Characters with spaces)As Project Director, Daisy Rodriguez, will oversee the overall CARE funding opportunity project. The team will include Mr. Andrew Pupke, the Director of Real Estate Management, an assigned REM Project Manager, the Human Services Grants Manager, and the Site Supervisor for the health center. As Director of Real Estate Management, Mr. Pupke is responsible for oversight of all County-owned buildings, including the Bayside Health Clinic. Mr. Pupke's team will be responsible for the alteration/renovation projects (elevated generator and shutters) described in this project. Working with the grants manager and purchasing department, the team will ensure all federal requirements are met. The project management team within Real Estate management has several years experience managing federal capital and locally funded capital improvement projects. The two projects described are fairly straightforward and we do not anticipate any major shifts in the project goals and objectives or timeframe. The team will develop a timeline, coordinate and communicate regularly via monthly meetings and teleconferences as needed, and pro-actively address any areas that may become challenges to completion of the project.

4. Project Timeline

Provide an overall project schedule, including the number of months for each of the following critical milestones within the two-year budget/project period (24 months): planning, design period, obtain required permits and/or variances, meet Federal environmental and historic preservation requirements, solicitation of bids and awarding of contracts, alteration/renovation or construction period, and expected project completion date. Describe the current status of the project including any steps that may have been accomplished to date and identify the person or entity accountable for each milestone.

Project Completion Date: 08/2020

Approximately 1 page (Max 2000 Characters with spaces)Within 90 days of award, the Real Estate Management team will assign a project manager, and initiate planning and architectural review of the existing generator and decisions regarding the type and quantity of hurricane shutters needed. The project manager will initiate, in consultation with purchasing, the protocol for procuring the service contracts and vendors needed for the project. Within six -eight months of award, the service provider/vendors will be established and contract agreements signed. Project implementation will be completed within 12-16 months following award for both projects. Monthly calls will be established between the Human Services Department, Health Center staff, and Real Estate Management to ensure adherence to project timelines, document progress, and communicate the status of the projects with the Board and leadership staff.

Attachments:

Provide following documents related to this site:

1. Project Budget Justification (Minimum 1) (Maximum 1)

Document Name	Size	Date Attached	Description
CARE Budget Justification_FINAL_Pinellas County.pdf	21 kB	06/14/2018	Budget Justification - Pinellas County

Environmental Information Documentation (EID) Checklist

Download Template		
Name	Description	Options
EID Checklist	Template for EID Checklist	Download ▼

2. Environmental Information Documentation (EID) Checklist (Minimum 1) (Maximum 1)

Document Name	Size	Date Attached	Description
EID Checklist_Signed.pdf	671 kB	06/14/2018	Final Signed EID Checklist - Pinellas County

3. Floor Plans/Schematic Drawings/Site Plan (Minimum 1) (Maximum 2)

Document Name	Size	Date Attached	Description
Generator Architectural Plans 2015.pdf	4 MB	06/13/2018	Attached are the architectural plans from when the building was constructed in 2015 related to the... (View More)

Budget (SF-424C)

As of 06/14/2018 09:04:37 AM
OMB Number: 0915-0285 OMB Expiration Date: 1/31/2020

Project Information

Project Title	Bayside Health Clinic - Hurricane Risk Mitigation	Project Type	Alteration / Renovation (A/R)	Project Tracking Number	155688-02	Amount requested in this project	\$107,075.00
---------------	---	--------------	-------------------------------	-------------------------	-----------	----------------------------------	--------------

Serial Number	Cost Classification	Total Cost (a)	Costs Not Allowable for Participation (b)	Total Allowable Costs (c = a - b)
1	Administrative and legal expenses	\$25,000.00	\$0.00	\$25,000.00
2	Land, structures, rights-of-way, appraisals, etc.	\$0.00	\$0.00	\$0.00
3	Relocation expenses and payments	\$0.00	\$0.00	\$0.00
4	Architectural and engineering fees	\$10,000.00	\$0.00	\$10,000.00
5	Other architectural and engineering fees	\$0.00	\$0.00	\$0.00
6	Project inspection fees	\$5,000.00	\$0.00	\$5,000.00
7	Site work	\$2,500.00	\$0.00	\$2,500.00
8	Demolition and removal	\$0.00	\$0.00	\$0.00
9	Construction	\$45,000.00	\$0.00	\$45,000.00
10	Equipment	\$17,200.00	\$0.00	\$17,200.00
11	Miscellaneous	\$0.00	\$0.00	\$0.00
12	SUBTOTAL (sum of lines 1-11)	\$104,700.00	\$0.00	\$104,700.00
13	Contingencies	\$2,375.00	\$0.00	\$2,375.00
14	SUBTOTAL (sum of lines 12 and 13)	\$107,075.00	\$0.00	\$107,075.00
15	Project (program) income	\$0.00	\$0.00	\$0.00
16	TOTAL PROJECT COSTS	\$107,075.00	\$0.00	\$107,075.00
17	Federal assistance requested Federal Percentage Share : 100.00 %			\$107,075.00

Funding Sources

As of 06/14/2018 09:04:37 AM

Project Information							
Project Title	Bayside Health Clinic - Hurricane Risk Mitigation	Project Type	Alteration / Renovation (A/R)	Project Tracking Number	155688-02	Amount requested in this project	\$107,075.00

Funding Sources Information				
1. Total Project Cost (From cell 16c of Budget form)	\$107,075.00			
2. Federal Grant Requested (From cell 17c of Budget form)	\$107,075.00			
3. Other Funding Sources	Amount Secured (a)	Amount Committed (b)	Amount Forthcoming (c)	Total (d = a + b + c)
3a. State Grants ⓘ	\$0.00	\$0.00	\$0.00	\$0.00
3b. Local Funding ⓘ	\$0.00	\$0.00	\$0.00	\$0.00
3c. Other Federal Funding ⓘ	\$0.00	\$0.00	\$0.00	\$0.00
3d. Private/Third Party Funding ⓘ	\$0.00	\$0.00	\$0.00	\$0.00
3e. Other Project Financing ⓘ	\$0.00	\$0.00	\$0.00	\$0.00
Total Other Funding Sources	\$0.00	\$0.00	\$0.00	\$0.00

Equipment List

As of 06/14/2018 09:04:37 AM
OMB Number: 0915-0285 OMB Expiration Date: 1/31/2020

Project Information							
Project Title	Bayside Health Clinic - Hurricane Risk Mitigation	Project Type	Alteration / Renovation (A/R)	Project Tracking Number	155688-02	Amount requested in this project	\$107,075.00

List of Equipment					
Type	Description	Unit Price	Quantity	Total Price	
Non-Clinical	Motorola 800 MHz radio	\$1,500.00	6	\$9,000.00	
Non-Clinical	Clorox Total 360 Sanitizing System (Sprayer)	\$4,000.00	2	\$8,000.00	
Non-Clinical	Clorox Total 360 Sanitizer Solution (Case)	\$100.00	1	\$100.00	
Non-Clinical	Clorox Total 360 Disinfectant Solution (Case)	\$100.00	1	\$100.00	
Total			10	\$17,200.00	

Form 5B - Service Sites

As of 06/14/2018 09:04:37 AM
OMB Number: 0915-0285 OMB Expiration Date: 1/31/2020

Project Information							
Project Title	Bayside Health Clinic - Hurricane Risk Mitigation	Project Type	Alteration / Renovation (A/R)	Project Tracking Number	155688-02	Amount requested in this project	\$107,075.00

Bayside Health Clinic (BPS-H80-018057)				Action Status: Picked from Scope
Site Name	Bayside Health Clinic	Physical Site Address	14808 49th Street N., Clearwater, FL 33762	
Site Type	Service Delivery Site	Site Phone Number	(727) 453-7866	
Web URL				
Location Type	Permanent	Site Setting	All Other Clinic Types	

Date Site was Added to Scope	6/3/2016	Site Operational By	6/3/2016
FQHC Site Medicare Billing Number Status		FQHC Site Medicare Billing Number	
FQHC Site National Provider Identification (NPI) Number		Total Hours of Operation	60
Months of Operation	May, June, July, August, January, February, March, April, September, October, December, November		
Number of Contract Service Delivery Locations		Number of Intermittent Sites	0
Site Operated by	Contractor		

Organization Information				
Organization Name	Address (Physical)	Address (Mailing)	EIN	Comments
Florida Department of Health in Pinellas County	205 Dr. Martin Luther King Street N St Petersburg, FL 33701		59-3502843	

Service Area Zip Codes	34689, 33770, 33764, 33707, 33705, 33755, 33756, 33771, 33772, 33760, 33765, 33762, 33711, 33714, 33701, 33713, 33702, 33709, 33712, 33781
------------------------	--

Other Requirements For Sites

As of 06/14/2018 09:04:37 AM
OMB Number: 0915-0285 OMB Expiration Date: 1/31/2020

Project Information							
Project Title	Bayside Health Clinic - Hurricane Risk Mitigation	Project Type	Alteration / Renovation (A/R)	Project Tracking Number	155688-02	Amount requested in this project	\$107,075.00

Site Information	
Name of Service Site	Bayside Health Clinic
Site Address	14808 49th Street N., Clearwater, FL 33762

1. Site Control and Federal Interest

1. Identify current status of property (If 'Leased', please provide Landlord Letter of Consent)
 Owned Leased

2. Cultural Resource Assessment and Historic Preservation Considerations

2a. Was the project facility constructed prior to 1975?
 Yes No

2b. Is the project facility 50 years or older?
 Yes No

2c. Does the overall proposed project include

- any renovation/modification to the exterior of the facility (including the installation of new signage), or
- ground disturbance activities (including installation of permanent access ramps, utility work, installation of curb cuts, fencing, and parking)?

Yes No

2d. Does the project involve renovation to a facility or site that is historically, culturally, or architecturally significant?
 Yes No

2e. Is the site located on current or historic Native American, Alaskan Native, Native Hawaiian, or equivalent, culturally significant land?
 Yes No

Attachments
 Note: Upload the Landlord Letter of Consent document only if you indicated that the property status is 'Leased' in question 1 of this form. Otherwise, do not upload the document.

▼ Landlord Letter of Consent (Maximum 1)

No documents attached

▼ Property Information (Minimum 1) (Maximum 1)

Document Name	Size	Date Attached	Description
05 InteriorDesign Dwg - 0413.pdf	315 kB	06/12/2018	Interior Site Plan

Close Window



ASSURANCES - CONSTRUCTION PROGRAMS

OMB Number: 0915-0285
Expiration Date: 09/30/2016

Public reporting burden for this collection of information is estimated to average 15 minutes per response, including time for reviewing instructions, searching existing data sources, gathering and maintaining the data needed, and completing and reviewing the collection of information. Send comments regarding the burden estimate or any other aspect of this collection of information, including suggestions for reducing this burden, to the Office of Management and Budget, Paperwork Reduction Project (0348-0042), Washington, DC 20503.

PLEASE DO NOT RETURN YOUR COMPLETED FORM TO THE OFFICE OF MANAGEMENT AND BUDGET. SEND IT TO THE ADDRESS PROVIDED BY THE SPONSORING AGENCY.

NOTE: Certain of these assurances may not be applicable to your project or program. If you have questions, please contact the Awarding Agency. Further, certain Federal assistance awarding agencies may require applicants to certify to additional assurances. If such is the case, you will be notified.

As the duly authorized representative of the applicant, I certify that the applicant:

1. Has the legal authority to apply for Federal assistance, and the institutional, managerial and financial capability (including funds sufficient to pay the non-Federal share of project costs) to ensure proper planning, management and completion of project described in this application.
2. Will give the awarding agency, the Comptroller General of the United States and, if appropriate, the State, the right to examine all records, books, papers, or documents related to the assistance; and will establish a proper accounting system in accordance with generally accepted accounting standards or agency directives.
3. Will not dispose of, modify the use of, or change the terms of the real property title or other interest in the site and facilities without permission and instructions from the awarding agency. Will record the Federal awarding agency directives and will include a covenant in the title of real property acquired in whole or in part with Federal assistance funds to assure non-discrimination during the useful life of the project.
4. Will comply with the requirements of the assistance awarding agency with regard to the drafting, review and approval of construction plans and specifications.
5. Will provide and maintain competent and adequate engineering supervision at the construction site to ensure that the complete work conforms with the approved plans and specifications and will furnish progressive reports and such other information as may be required by the assistance awarding agency or State.
6. Will initiate and complete the work within the applicable time frame after receipt of approval of the awarding agency.
7. Will establish safeguards to prohibit employees from using their positions for a purpose that constitutes or presents the appearance of personal or organizational conflict of interest, or personal gain.
8. Will comply with the Intergovernmental Personnel Act of 1970 (42 U.S.C. §§4728-4763) relating to prescribed standards of merit systems for programs funded under one of the 19 statutes or regulations specified in Appendix A of OPM's Standards for a Merit System of Personnel Administration (5 C.F.R. 900, Subpart F).
9. Will comply with the Lead-Based Paint Poisoning Prevention Act (42 U.S.C. §§4801 et seq.) which prohibits the use of lead-based paint in construction or rehabilitation of residence structures.
10. Will comply with all Federal statutes relating to non-discrimination. These include but are not limited to: (a) Title VI of the Civil Rights Act of 1964 (P.L. 88-352) which prohibits discrimination on the basis of race, color or national origin; (b) Title IX of the Education Amendments of 1972, as amended (20 U.S.C. §§1681 1683, and 1685-1686), which prohibits discrimination on the basis of sex; (c) Section 504 of the Rehabilitation Act of 1973, as amended (29 U.S.C. §794), which prohibits discrimination on the basis of handicaps; (d) the Age Discrimination Act of 1975, as amended (42 U.S.C. §§6101-6107), which prohibits discrimination on the basis of age; (e) the Drug Abuse Office and Treatment Act of 1972 (P.L. 92-255), as amended relating to nondiscrimination on the basis of drug abuse; (f) the Comprehensive Alcohol Abuse and Alcoholism Prevention, Treatment and Rehabilitation Act of 1970 (P.L. 91-616), as amended, relating to nondiscrimination on the basis of alcohol abuse or alcoholism; (g) §§523 and 527 of the Public Health Service Act of 1912 (42 U.S.C. §§290 dd-3 and 290 ee 3), as amended, relating to confidentiality of alcohol and drug abuse patient records; (h) Title VIII of the Civil Rights Act of 1968 (42 U.S.C. §§3601 et seq.), as amended, relating to nondiscrimination in the sale, rental or financing of housing; (i) any other nondiscrimination provisions in the specific statute(s) under which application for Federal assistance is being made; and (j) the requirements of any other nondiscrimination statute(s) which may apply to the application.

11. Will comply, or has already complied, with the requirements of Titles II and III of the Uniform Relocation Assistance and Real Property Acquisition Policies Act of 1970 (P.L. 91-646) which provide for fair and equitable treatment of persons displaced or whose property is acquired as a result of Federal and federally-assisted programs. These requirements apply to all interests in real property acquired for project purposes regardless of Federal participation in purchases.
12. Will comply with the provisions of the Hatch Act (5 U.S.C. §§1501-1508 and 7324-7328) which limit the political activities of employees whose principal employment activities are funded in whole or in part with Federal funds.
13. Will comply, as applicable, with the provisions of the Davis-Bacon Act (40 U.S.C. §§276a to 276a-7), the Copeland Act (40 U.S.C. §276c and 18 U.S.C. §874), and the Contract Work Hours and Safety Standards Act (40 U.S.C. §§327-333) regarding labor standards for federally-assisted construction subagreements.
14. Will comply with flood insurance purchase requirements of Section 102(a) of the Flood Disaster Protection Act of 1973 (P.L. 93-234) which requires recipients in a special flood hazard area to participate in the program and to purchase flood insurance if the total cost of insurable construction and acquisition is \$10,000 or more.
15. Will comply with environmental standards which may be prescribed pursuant to the following: (a) institution of environmental quality control measures under the National Environmental Policy Act of 1969 (P.L. 91-190) and Executive Order (EO) 11514; (b) notification of violating facilities pursuant to EO 11738; (c) protection of wetlands pursuant to EO 11990; (d) evaluation of flood hazards in floodplains in accordance with EO 11988; (e) assurance of project consistency with the approved State management program developed under the Coastal Zone Management Act of 1972 (16 U.S.C. §§1451 et seq.); (f) conformity of Federal actions to State (Clean Air) implementation Plans under Section 176(c) of the Clean Air Act of 1955, as amended (42 U.S.C. §§7401 et seq.); (g) protection of underground sources of drinking water under the Safe Drinking Water Act of 1974, as amended (P.L. 93-523); and, (h) protection of endangered species under the Endangered Species Act of 1973, as amended (P.L. 93-205).
16. Will comply with the Wild and Scenic Rivers Act of 1968 (16 U.S.C. §§1271 et seq.) related to protecting components or potential components of the national wild and scenic rivers system.
17. Will assist the awarding agency in assuring compliance with Section 106 of the National Historic Preservation Act of 1966, as amended (16 U.S.C. §470), EO 11593 (identification and protection of historic properties), and the Archaeological and Historic Preservation Act of 1974 (16 U.S.C. §§469a-1 et seq).
18. Will cause to be performed the required financial and compliance audits in accordance with the Single Audit Act Amendments of 1996 and OMB Circular No. A-133, "Audits of States, Local Governments, and Non-Profit Organizations."
19. Will comply with all applicable requirements of all other Federal laws, executive orders, regulations, and policies governing this program.
20. Will comply with the requirements of Section 106(g) of the Trafficking Victims Protection Act (TVPA) of 2000, as amended (22 U.S.C. 7104) which prohibits grant award recipients or a sub-recipient from (1) Engaging in severe forms of trafficking in persons during the period of time that the award is in effect (2) Procuring a commercial sex act during the period of time that the award is in effect or (3) Using forced labor in the performance of the award or subawards under the award.

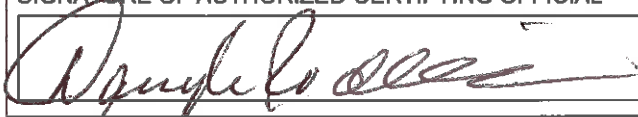
SIGNATURE OF AUTHORIZED CERTIFYING OFFICIAL 	TITLE Health Care Administrator
APPLICANT ORGANIZATION Pinellas County Board of County Commissioners	DATE SUBMITTED 06/14/2018

PINELLAS COUNTY BUDGET JUSTIFICATION

Project Number: 155688-02

Project Name: Pinellas County Emergency Management Project

Project Type: Equipment Only

Total CARE Funding Request = \$107,075

Total Project Cost = \$107,075

This application proposes minor alteration and renovation at our existing Bayside Health Clinic service site. The project proposes to minor alterations to 3,000 square feet. The County will be elevating the existing generator to mitigate flooding damage and be able to provide power to critical equipment and a portion of the site to provide better conditions in the cases of any future weather related events. Hurricane shutters will be installed on all the clinic windows. In addition, clinical and non-clinical equipment will be purchased.

Renovation related activities are anticipated to begin within 120 days of obtaining all local and HRSA approvals and are to be completed within 24 months after the award.

The total cost of the project is **\$107,075**. This CARE application requests **\$107,075** in one-time funding to cover a portion of the renovation and equipment costs.

	ALLOWABLE COSTS - CARE	UNALLOWABLE COSTS
Line 1— Administrative and legal expenses	\$25,000 for internal real estate management project management staff to oversee the alteration/ renovation projects.	
Line 2—Land, structures, right- of-way, appraisals, etc.	N/A	
Line 3—Relocation expenses and payments	N/A	
Line 4— Architectural and engineering fees	\$10,000 for architectural review and design to elevate the generator and specify selection and installation of window shutters.	
Line 5—Other architectural and engineering fees	N/A	
Line 6—Project inspection fees	\$5,000 for project inspection fees. The inspections will be conducted in accordance with the County Building Department standards and applicable building codes.	
Line 7—Site work	\$2,500 for site work to raise the emergency generator to a higher elevation.	
Line 8—Demolition and removal	N/A	

<p>Line 9— Construction</p>	<p>\$45,000 to enhance and mitigate risk of approximately 3,000 square feet of existing space. Estimates below are rough budgetary estimates as additional time is needed to obtain quotes from vendors for actual work.</p> <p>This renovation cost is derived from the following cost breakdown: construction (\$25,000 - generator), and construction (\$20,000 – window shutters).</p> <p>The construction cost of \$25,000 is comprised of the following: constructing a new raised structure on which to install the generator, rework of electrical and fuel piping connections.</p> <p>The construction cost of \$20,000 is for exterior hurricane window shutters to cover floor to ceiling windows and installation.</p>	
<p>Line 10 --- Equipment</p>	<p>\$17,200 for loose, movable non-clinical equipment items.</p> <p>See itemized equipment list for additional information.</p>	
<p>Line 11— Miscellaneous</p>	<p>N/A - All work required for this project has been shown in the cost classifications above.</p>	
<p>Line 12— SUBTOTAL</p>	<p style="text-align: center;">\$104,700 (The sum of Lines 1 through 11, allowable and unallowable)</p>	
<p>Line 13— Contingencies</p>	<p>\$2,375, which is 5% of the allowable costs shown in lines 7, 8, and 9.</p>	
<p>Line 14— SUBTOTAL</p>	<p style="text-align: center;">\$107,075 (The sum of Lines 12 and 13)</p>	
<p>Line 15—Project (program) income</p>	<p style="text-align: center;">None</p>	
<p>Line 16—TOTAL PROJECT COSTS</p>	<p style="text-align: center;">\$107,075 (Enter the amount in Line 14)</p>	

<p style="text-align: center;">DEPARTMENT OF HEALTH AND HUMAN SERVICES</p> <p style="text-align: center;">HEALTH RESOURCES AND SERVICES ADMINISTRATION</p> <p style="text-align: center;">ENVIRONMENTAL INFORMATION AND DOCUMENTATION (EID)</p>	FOR HRSA USE ONLY		
	Grantee Name		
	Grant Number		Application Tracking #
	Project #		Project Type
	Project Title		
<p>This Environmental Information and Documentation (EID) checklist consists of information that the agency is required to obtain to comply with the National Environmental Policy Act of 1969 (NEPA). NEPA establishes the Federal government's national policy for protection of the environment. HRSA has developed the EID for applicants of funding that would potentially impact the environment and to ensure that their decision-making processes are consistent with NEPA. Applicants must provide information and requested on the EID checklist so that HRSA may ensure compliance with NEPA.</p> <p>HRSA will provide applicants with the results of the agency's environmental review through the NGA. If HRSA determines that additional environmental compliance is necessary, HRSA will notify applicable grantees of specific requirements.</p> <p>Public Burden Statement: An agency may not conduct or sponsor, and a person is not required to respond to, a collection of information unless it displays a valid OMB control number. The OMB control number for this project is 0915-0324. Public reporting burden for this collection of information is estimated to average .75 hour per response, including the time for reviewing instructions, searching existing data sources, and completing and reviewing the collection of information. Send comments regarding this burden estimate or any other aspect of this collection of information, including suggestions for reducing this burden, to: HRSA Reports Clearance Officer, 5600 Fishers Lane, Room 10-29, Rockville, Maryland, 20857.</p>			
<p>Grantee Authorized Official: Phone: Email:</p> <p>Grantee EID Preparer: Phone: Email Address:</p>			
<p>Project Location/Address (Please note - separate EID forms are required for each project location) Please provide the address where the action will occur (e.g. where equipment will be located or where renovations/new construction will occur)</p>			
<p>Scope of work Describe all actions that are part of the proposed action (Please include a description of the entire project, including elements that will use non-federal funding)</p>			

Site Description - required for all building renovations (e.g. interior renovations, new windows, roofs, etc.) and new construction (including building additions, temporary facilities, and trailers)

Site acreage:

Land use on site:

Land use surrounding site (current use, zoning and proposed changes if applicable):

Buildings currently on site (stories, height, age, total sq. footage):

Vegetation on site (e.g. grasses, shrub, heavily wooded, none because it's paved, etc.):

Streams/wetlands on site or adjacent to the site:

Proposed ground disturbance (sq. footage):

A. Scope of Proposed Action

This set of questions is concerned with size and scope of the proposed action

A.1. Will the action involve the purchase, construction or lease of new facilities (including temporary facilities and trailers), or substantially increase the capacity of an existing health care facility?

Yes No

If yes explain:

A.2. Is the action significantly greater in scope than other development taking place in the area, or will it have significant unusual characteristics?

Yes No

If yes explain:

B. Potential for Public Controversy

This set of questions is concerned with whether or not the proposed action has or could generate public controversy.

B.1. Are there any public concerns or controversy with respect to effects of the action on environmental or cultural resources based on reasonable and substantial issues?

Yes No

B.2. Have comments on the action's impacts to environmental or cultural resources been received from the public or from local, State, or Federal agencies?

Yes No

If yes explain:

C. Degradation of Environmental Conditions

This set of questions concerns the potential for actions to degrade, even slightly, already existing poor environmental conditions.

C.1. Will the action increase identifiable ambient air pollution levels from a new emission source or from existing sources (e.g., lab fume hoods, HVAC systems, etc.)?

Yes No

If yes explain:

C.2. Will the action increase identifiable ambient air pollution levels through a major increase in the number of or use of automobiles, trucks (e.g., will there be a large number of new employees or patients traveling to the site, or a large number of deliveries to the site)?

Yes No

C.3. Will the action exceed city or State health or Federal air quality standards with exhausts from fume hoods

Yes No

If yes explain:

C.4. Will the action cause or increase soil erosion?

Yes No

If yes explain(For building additions and/or new construction, please list measures to be taken to control sedimentation and soil erosion):

C.5. Will the action discharge stormwater or pollutants into a stream, river, lake, etc.?

Yes No

If yes explain(For building additions and/or new construction, please note any stormwater management practices to be utilized):

C.6. Will the action overload existing waste treatment plants due to new loads (water volume, chemicals, toxicity, etc.)?

Yes No

If yes, please obtain and submit a connection permit or other approval from local sewer authority.

C.7. Will the action allow seepage of contaminants into the water table?

Yes No

If yes explain:

D. New or Unproven Technology

This set of questions is concerned with the deployment of new or unproven technology with the potential adverse effects or actions involving unique or unknown environmental risks

D.1. Will the action involve the purchase or use of new or unproven technology?

Yes No

If yes explain:

D.2. Will the action involve the purchase or use of technology for which the environmental impacts are unknown?

Yes No

If yes explain:

E. Presence of cultural, archaeological, historical or other protected resources

This set of questions is concerned with potential impacts to cultural resources including, but not limited to, buildings; archaeological sites; National Historic Landmarks; objects of significance to a Native American Tribe including graves, funerary objects, and traditional cultural properties; or other protected resources. HRSA will provide applicants with the results of the agency's historic preservation assessment through the Notice of Grant Award (NGA). If HRSA determines that additional review by the State Historic Preservation Office (SHPO) is necessary, HRSA will instruct applicable grantees on how to initiate consultation with the SHPO.

E.1. Will the action involve the purchase, construction, alteration, renovation, or lease of real property or portion of real property?

Yes No

If yes, when was the building constructed?

E.2. Will the proposed action occur in or near a building listed on or eligible for listing on the National Register of Historic Places?
 Yes No

E.3. Will the proposed action adversely affect properties listed on or eligible for listing on the National Register of Historic Places?
 Yes No

If yes explain:

E.4. Will the action encroach upon, change views to, or change noise levels around any historical, architectural, or archeological cultural property?
 Yes No

If yes explain:

F. Protected Species

This set of questions is concerned with protected plant and animals, including endangered or threatened species or their critical habitat.

F.1. Will the action be likely to adversely affect a plant or animal species listed on the Federal or applicable State list of endangered or threatened species or a specific critical habitat of an endangered or threatened species? For assistance, contact the appropriate State Fish and Wildlife Agency or the regional office of the U.S. Fish and Wildlife Service.
 Yes No

If yes explain:

F.2. Will the action adversely affect nesting Bald Eagles or migratory birds?
 Yes No

If yes explain:

G. Special Status Areas and Critical Resources

These questions are concerned with actions with the potential to adversely affect special status areas or other critical resources such as wetlands, floodplains, coastal zones, wildlife refuge and wilderness areas, wild and scenic rivers, or sole or principal drinking water aquifers.

G.1. Are there wetlands or waters of the U.S. on or adjacent to the site?

Yes No

If yes, attach National Wetland Inventory Map, State or local map, or site specific map

G.2. Will the action include discharge to or the filling or dredging of wetlands?

Yes No

If yes explain:

G.3. Will the action require a section 404 (Clean Water Act) permit for actions in a wetland and/or section 10 (Rivers and Harbors Act) permit for actions in a stream or river? (Activities in or near a wetland or river may require a permit from the U.S. Army Corps of Engineers or U.S. Coast Guard. Includes: construction in or near any wet or dry waterway, stream crossings, intake structures, outfalls, etc.)

Yes No

If yes, provide status of permit process:

G.4. Is the project site located in either a 100-year or a 500-year floodplain?

Yes No

Regardless of whether the project is in a known floodplain, please attach a Flood Insurance Rate Map to this document. **Clearly mark** the location of the facility, and the NFIP Panel Number. FIRMettes can be generated electronically at no cost at the [FEMA Map Service Center](#) website. The FIRMette module is located in the upper left hand corner, while the tutorial is at the lower right hand corner of the webpage. (If Flood Insurance Rate Maps do not exist for the project site, a floodplain survey or consultation may be required.)

G.5. Will the proposed action include new construction or new site features (e.g., new buildings, additions, fences, parking lots, signage, etc.) in the floodplain?

Yes No

If yes explain:

G.6. Will the proposed action adversely impact flood flows in a floodplain or support development in a floodplain?
 Yes No

If yes explain:

G.7. Will the proposed action include alter floodplain levels?
 Yes No

If yes explain:

G.8. Will the proposed action discharge stormwater to the floodplain?
 Yes No

If yes explain:

G.9. Is the project located in a state that borders the Atlantic Ocean, Pacific Ocean, Great Lake, Chesapeake Bay, or Gulf of Mexico?
 Yes No N/A

If yes, is your project located in the state's coastal zone?

Yes No N/A

If yes, you may be asked in your NGA to contact your state coastal zone agency for a Section 307 Federal Coastal Zone Consistency Determination.

G.10. Will the action adversely affect a specifically designated Wildlife Refuge or Wilderness Area?
For assistance contact your State Fish and Wildlife Agency or the regional office of the U.S. Fish and Wildlife Service, .Bureau of Land Management, U.S. Forest Service, or National Park Service.
 Yes No

If yes explain:

G.11. Will the action adversely affect a wild, scenic, or recreational river area or create conditions inconsistent with the character of the river? (A consideration for activities that are in or near any wild and scenic waterway including construction of stream/river crossings, intake structures, outfalls, etc.)

Yes No

If yes explain:

G.12. Will the action adversely impact an EPA designated sole source aquifer? (Designation of sole source aquifer puts restrictions and conditions on Federal expenditures, projects, and grants.)

Yes No

If yes explain:

H. Pollutants

This set of questions is concerned with the presence of hazardous, toxic, or petroleum substances at levels which exceed Federal, state, or local regulations or standards requiring action or attention.

H.1. Will the action include renovation of an existing building or ground disturbing activities?

Yes No

If yes, has a Phase I Environmental Site Assessment been prepared for the property within the last 3 years?

H.2. Will the action take place on a site where past land uses may have led to contamination of soil, surface water, or groundwater?

Yes No

If yes explain:

I. Health and Safety

This set of questions is concerned with the potential for adverse impacts to human health and safety from the proposed action.

I.1. Will the action introduce major new sources of unshielded radiation?

Yes No

If yes explain:

<p>I.2. Will the action require storage of waste pending technology for safe disposal? <input type="checkbox"/> Yes <input type="checkbox"/> No</p> <p>If yes explain:</p>
<p>I.3. Will the action adversely affect access to transportation, health, education, and/or welfare service? <input type="checkbox"/> Yes <input type="checkbox"/> No</p> <p>If yes explain:</p>
<p>I.4. Will the action result in changes in genetic engineering directed at the human population? <input type="checkbox"/> Yes <input type="checkbox"/> No</p> <p>If yes explain:</p>
<p>I.5. Will the action cause a new, large volume of production of non-recycled items? <input type="checkbox"/> Yes <input type="checkbox"/> No</p> <p>If yes explain:</p>
<p>I.6. Could the action disrupt existing health services' response in case of a disaster? <input type="checkbox"/> Yes <input type="checkbox"/> No</p> <p>If yes explain:</p>
<p>I.7. Will the action decrease accessibility to routine health services by altering point-of-service delivery? <input type="checkbox"/> Yes <input type="checkbox"/> No</p> <p>If yes explain:</p>

I.8. Will the action increase by more than 5% the patient load of the area's routine care services?
 Yes No

If yes explain:

J. Environmental Justice (Executive Order 12898)

This set of questions is concerned with consistency with Executive Order 12898, Environmental Justice in Minority Populations and Low-Income Populations

J.1. Are there low-income or minority populations in the vicinity of the proposed action?
 Yes No

If yes explain:

J.2. Will the action have disproportionately high and adverse human health or environmental effects on minority populations and low-income populations?
 Yes No

If yes explain:

J.3. Will the proposed action displace or relocate low-income or minority populations?
 Yes No

If yes explain:

K. Other Federal, State, Local, or Tribal Laws

This set of questions is concerned with consistency with other federal, state, local or tribal laws or requirement imposed for the protection of the environment.

K.1. Will the action convert significant agricultural lands to non-agricultural uses or impact Prime Farmland Soils or Solis of Statewide Importance?
 Yes No

If yes explain:

K.2. Will the action change traditional use of the land parcel (by rezoning, etc.)?

Yes No

If yes, has zoning change been requested and/or received? Explain

If yes, complete the following:

Present Zoning: _____

Present Use of Site: _____

Proposed Zoning: _____

K.3. Will the action have significant adverse direct or indirect effects on park land, other public lands, or areas of recognized scenic or recreational value? (For example, consider how the activity will affect the view?)

Yes No

If yes explain:

K.4. Will the action block access to known mineral deposits? (Sand, gravel, clay, stone, or other common building materials are not considered mineral deposits.)

Yes No

If yes explain:

L. Cumulative Impacts

Potential for significant cumulative impact when the proposed action is combined with other past, present and reasonably foreseeable future actions, even though the impacts of the proposed action may not be significant by themselves.

L.1. Has the area around the project undergone major changes in land use/development?

Yes No

If yes explain:

L.2. Are major changes in land use/development planned for the area around the project?

Yes No

If yes explain:

L.3. Will the action alter the use of other land by related development of stores, roads, or site changes?
 Yes No

If yes explain:

M. Mitigative Measures

Please discuss any mitigative measures undertaken to minimize any environmental impacts. For example, utilizing the EPA's Energy Performance Environmental Assessment Tool (EPEAT) or EnergyStar guidance as part of IT selection and purchase criteria, using EPA's Environmentally Preferred Purchasing Guidance for 'green' products and services, or incorporating Sustainable Design or Leadership in Energy and Environmental Design (LEED) standards into alteration/renovation or new construction project.

Describe mitigative measures that will be incorporated into the action:
 None required.

ENVIRONMENTAL INFORMATION AND DOCUMENTATION CERTIFICATION

I certify that to the best of my knowledge and ability the information presented herein is true and correct (enter appropriate information in the shaded blanks):

Daisy Rodriguez Health Care Administrator 727-464-4206 06/12/2018

Signature (Type Full Name):  Title or Position: Phone Number: Date:
 (Grantee or responsible, knowledgeable person who completed this document)

Andrew Pupke Real Estate Management Director 727-464-3237 06/13/18

Signature (Type Full Name):  Title or Position: Phone Number: Date:
 (Grantee Authorized Representative)

Public Burden Statement: An agency may not conduct or sponsor, and a person is not required to respond to, a collection of information unless it displays a valid OMB control number. The OMB control number for this project is 0915-0324. Public reporting burden for this collection of information is estimated to average 1 hour per response, including the time for reviewing instructions, searching existing data sources, and completing and reviewing the collection of information. Send comments regarding this burden estimate or any other aspect of this collection of information, including suggestions for reducing this burden, to: HRSA Reports Clearance Officer, 5600 Fishers Lane, Room 10-33, Rockville, Maryland, 20857.

National Flood Hazard Layer FIRMMette



27°54'36.47"N

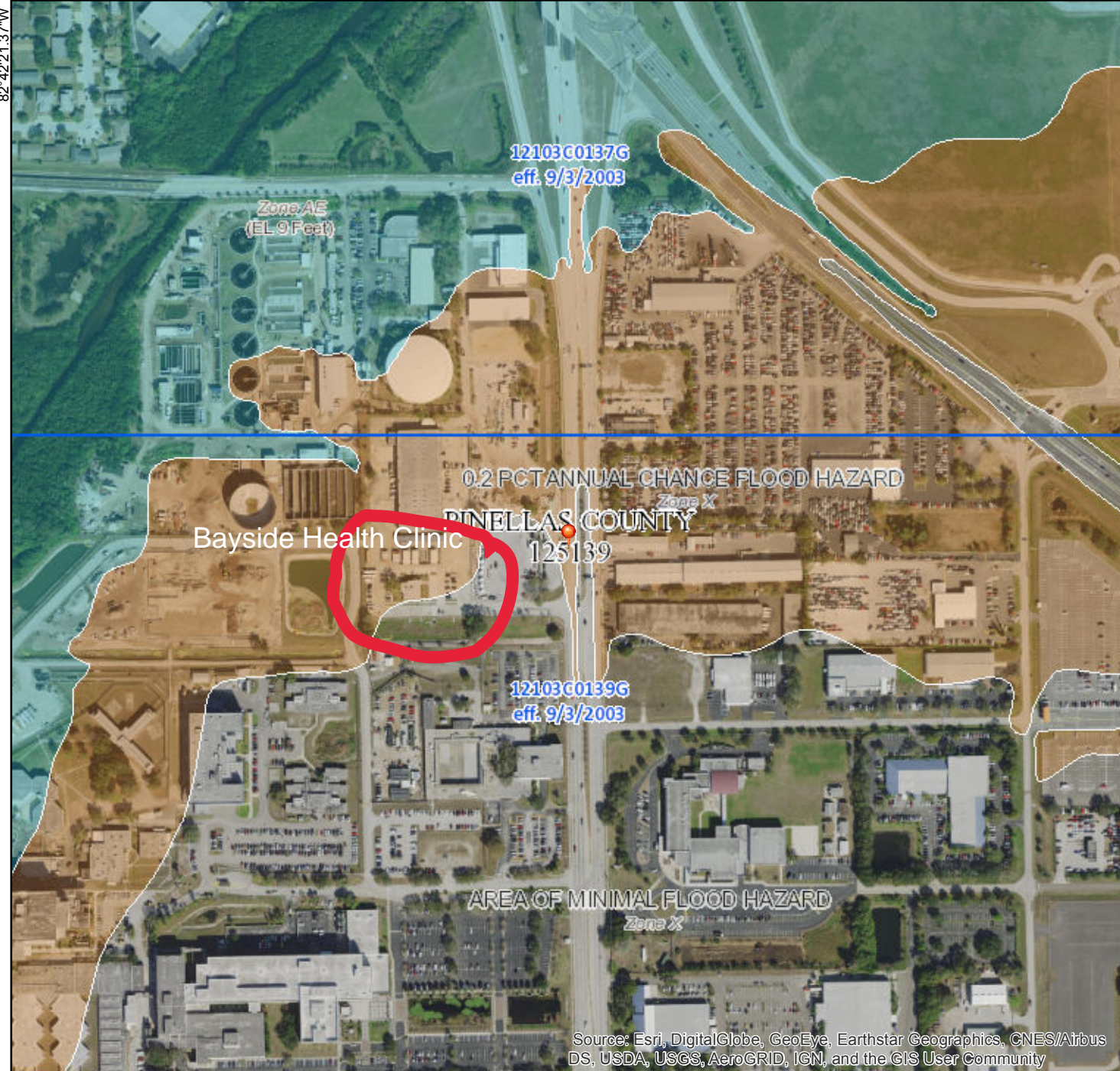

Source: Esri, DigitalGlobe, GeoEye, Earthstar Geographics, CNES/Airbus DS, USDA, USGS, AeroGRID, IGN, and the GIS User Community

Legend

SEE FIS REPORT FOR DETAILED LEGEND AND INDEX MAP FOR FIRM PANEL LAYOUT

SPECIAL FLOOD HAZARD AREAS		Without Base Flood Elevation (BFE) Zone A, V, A99
		With BFE or Depth Regulatory Floodway Zone AE, AO, AH, VE, AR
OTHER AREAS OF FLOOD HAZARD		0.2% Annual Chance Flood Hazard, Areas of 1% annual chance flood with average depth less than one foot or with drainage areas of less than one square mile Zone X
		Future Conditions 1% Annual Chance Flood Hazard Zone X
		Area with Reduced Flood Risk due to Levee. See Notes. Zone X
		Area with Flood Risk due to Levee Zone D
OTHER AREAS		NO SCREEN Area of Minimal Flood Hazard Zone X
		Effective LOMRs
GENERAL STRUCTURES		Area of Undetermined Flood Hazard Zone D
		Channel, Culvert, or Storm Sewer
OTHER FEATURES		Levee, Dike, or Floodwall
		20.2 Cross Sections with 1% Annual Chance Water Surface Elevation
MAP PANELS		17.5 Coastal Transect
		Base Flood Elevation Line (BFE)
OTHER FEATURES		Limit of Study
		Jurisdiction Boundary
OTHER FEATURES		Coastal Transect Baseline
		Profile Baseline
OTHER FEATURES		Hydrographic Feature
		Digital Data Available
MAP PANELS		No Digital Data Available
		Unmapped



This map complies with FEMA's standards for the use of digital flood maps if it is not void as described below. The base map shown complies with FEMA's base map accuracy standards

The flood hazard information is derived directly from the authoritative NFHL web services provided by FEMA. This map was exported on **6/12/2018 at 1:34:46 PM** and does not reflect changes or amendments subsequent to this date and time. The NFHL and effective information may change or become superseded by new data over time.

This map image is void if the one or more of the following map elements do not appear: base map imagery, flood zone labels, legend, scale bar, map creation date, community identifiers, FIRM panel number, and FIRM effective date. Map images for unmapped and unmodernized areas cannot be used for regulatory purposes.

0 250 500 1,000 1,500 2,000 Feet 1:6,000 27°54'4.68"N 82°41'43.91"W

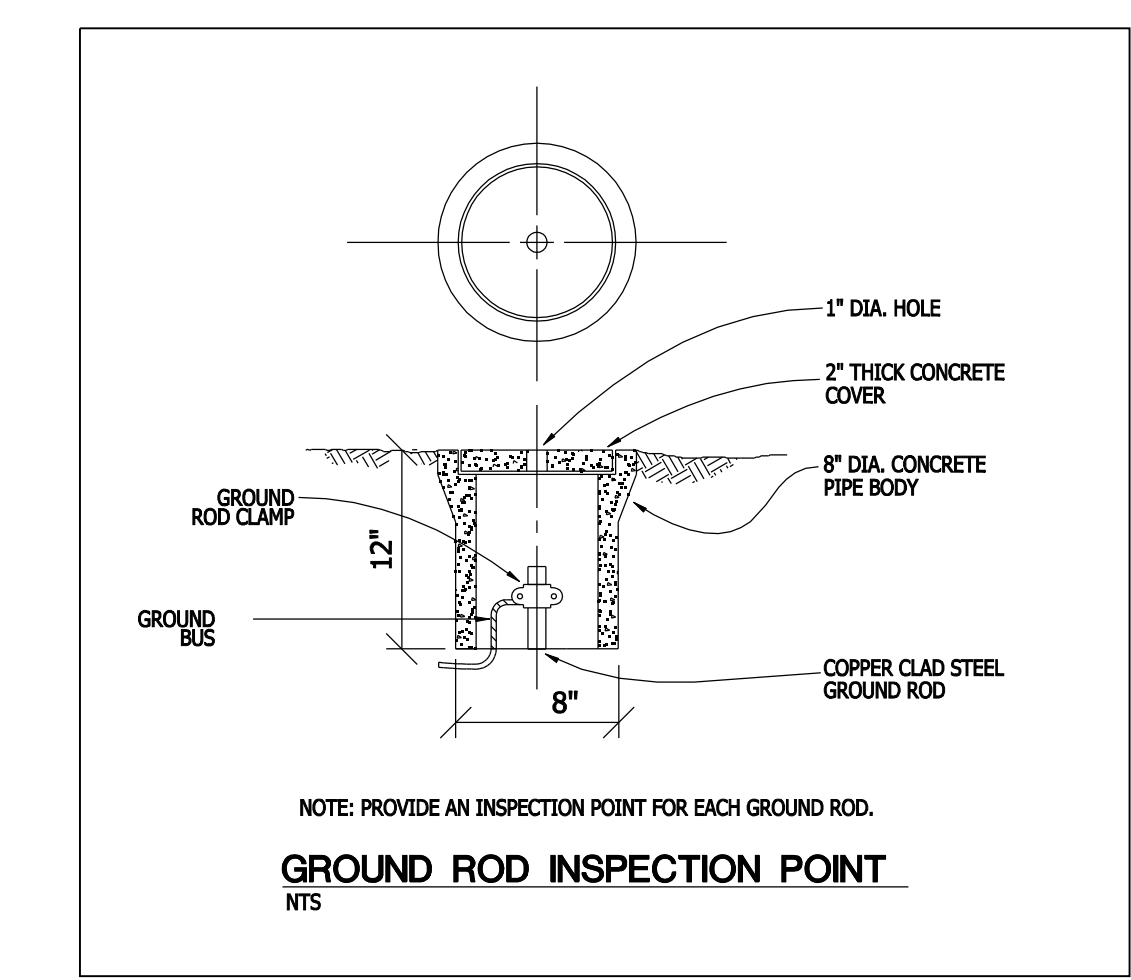
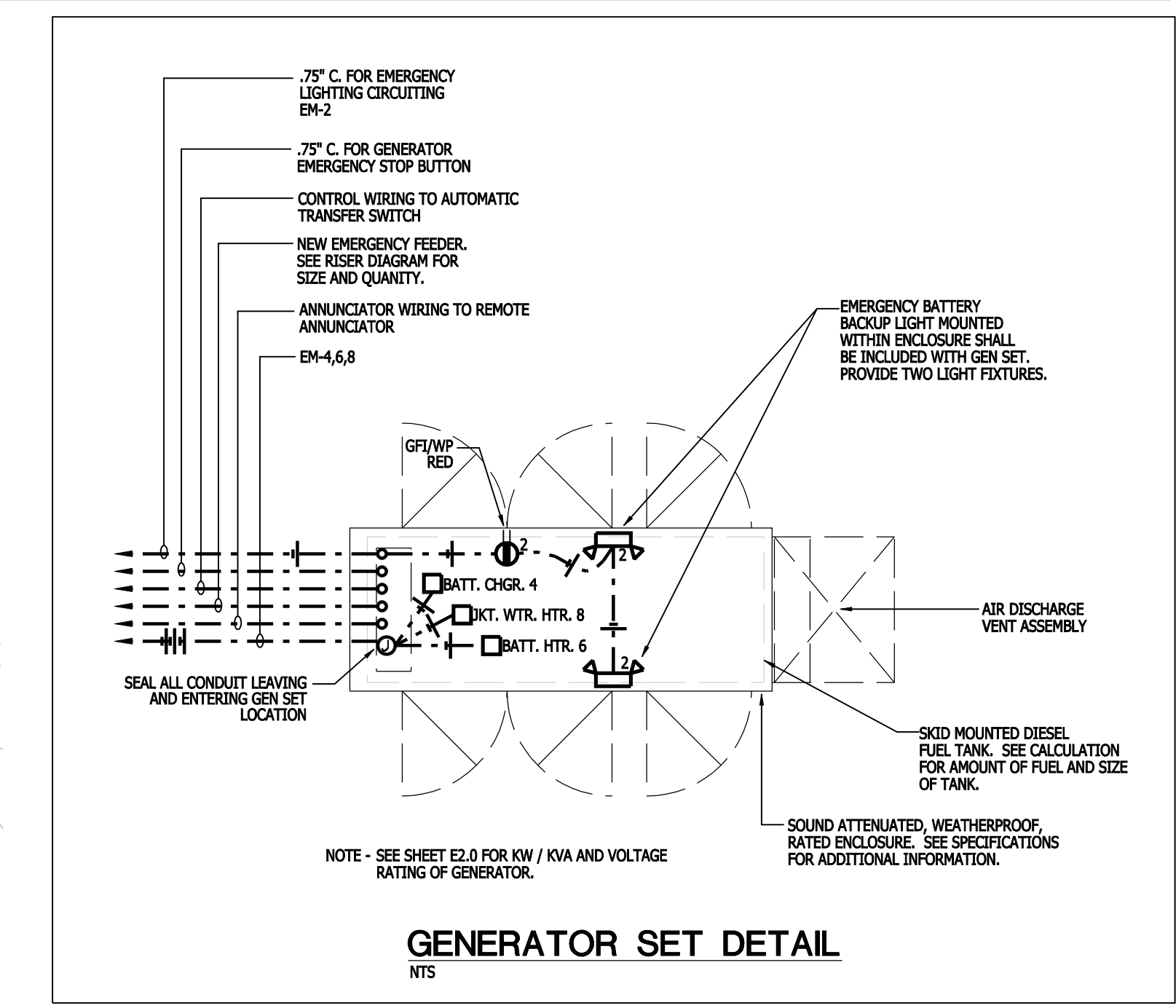
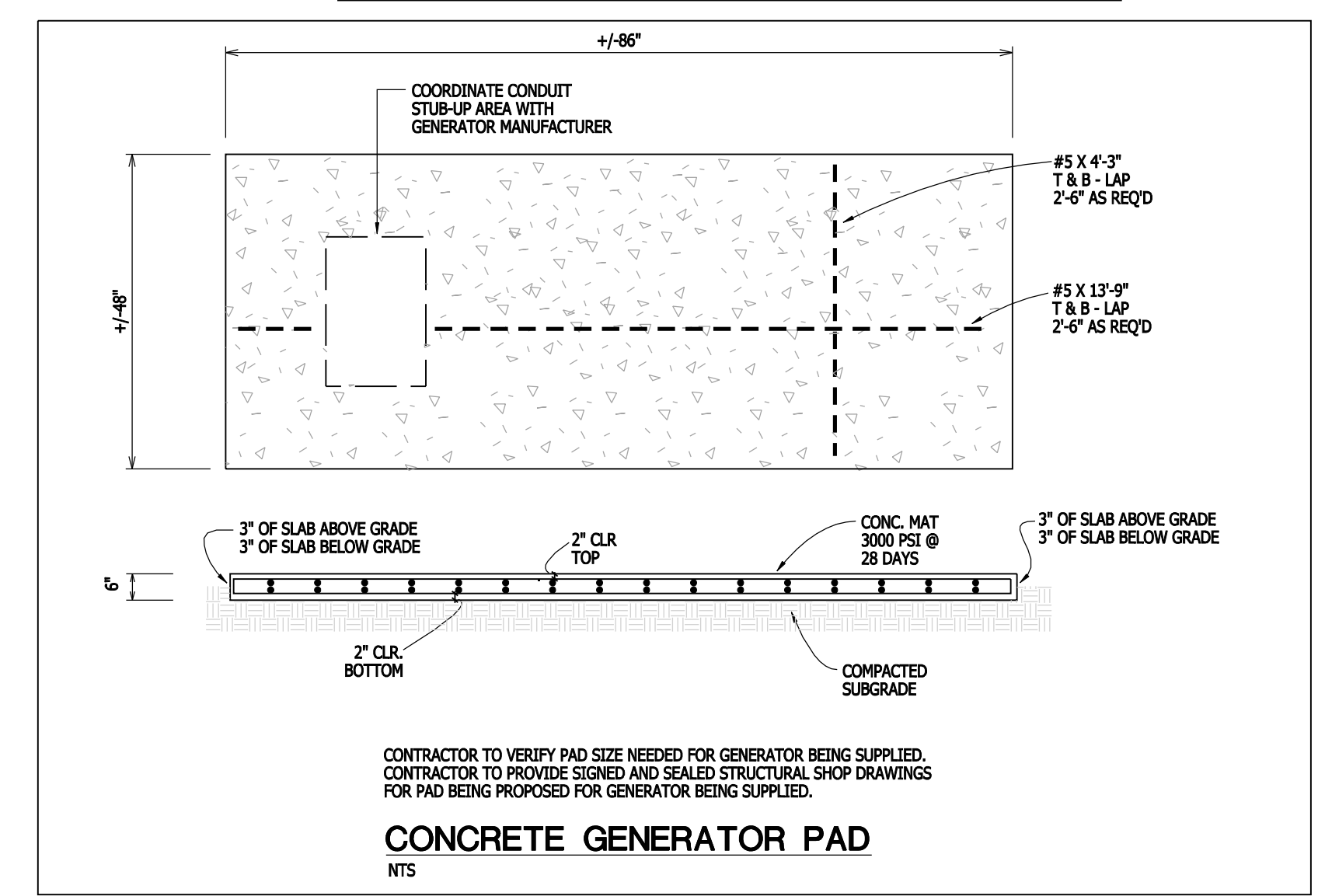
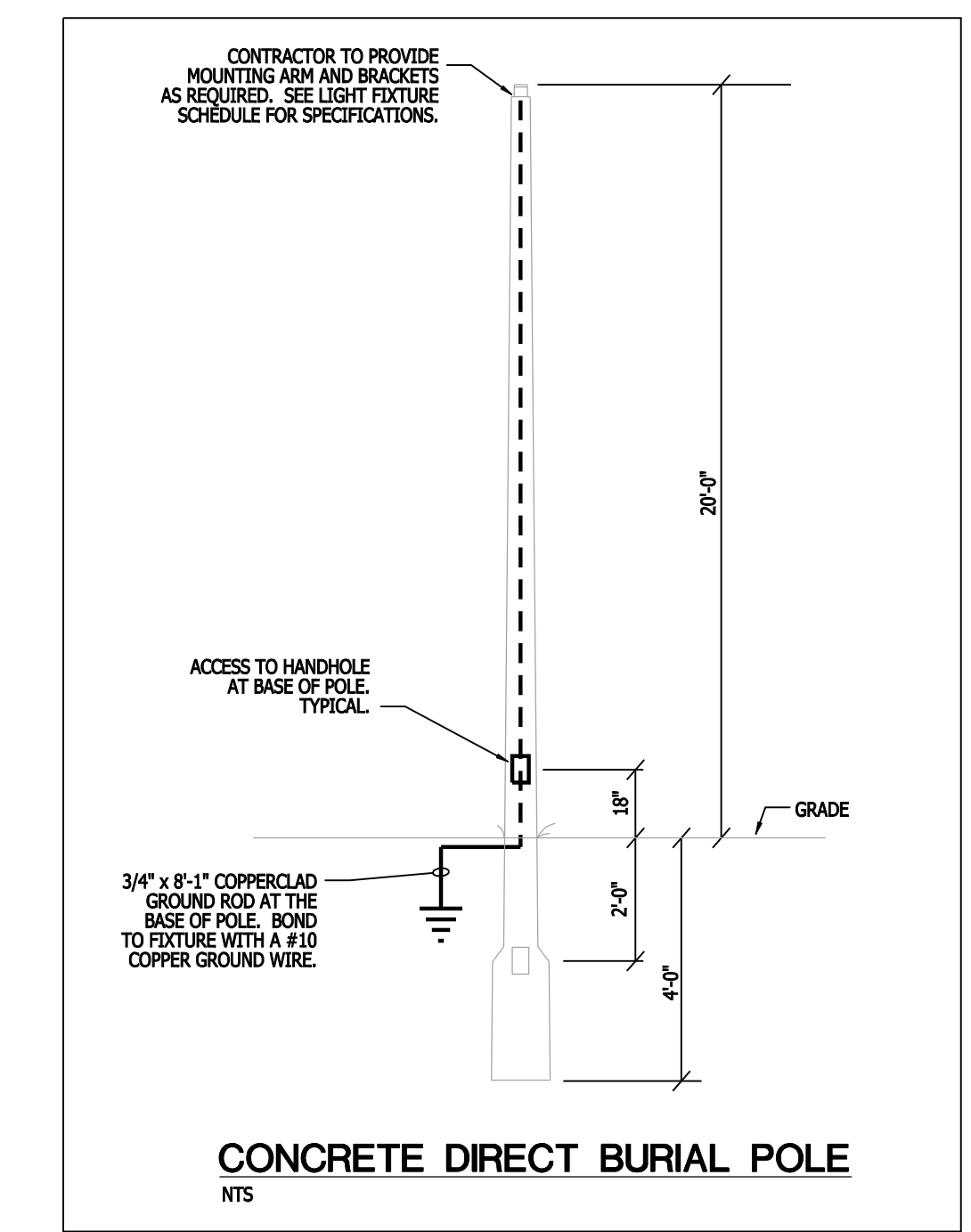

- NOTES**
- UTILITY COMPANY PAD MOUNTED TRANSFORMER. MAINTAIN ALL REQUIRED WORKING CLEARANCES. 120Y208V, 3P4W SECONDARY.
 - PROVIDE UTILITY METER ON ON 4' SQUARE CONCRETE POST ADJACENT TO TRANSFORMER.
 - SEE RISER DIAGRAM FOR WIRING REQUIREMENTS.

ELECTRICAL SITE PLAN
 SCALE 1" = 20'-0"

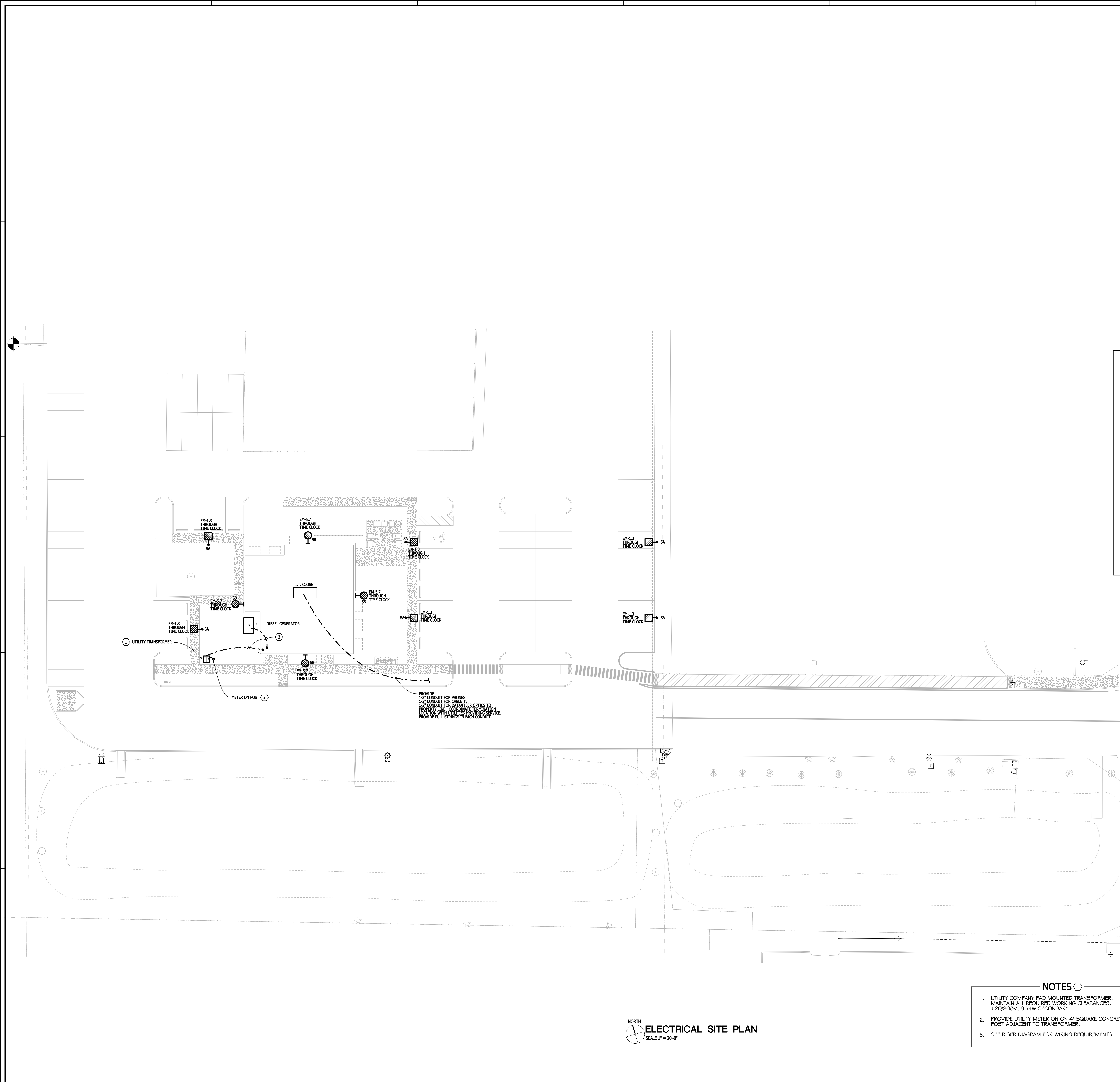

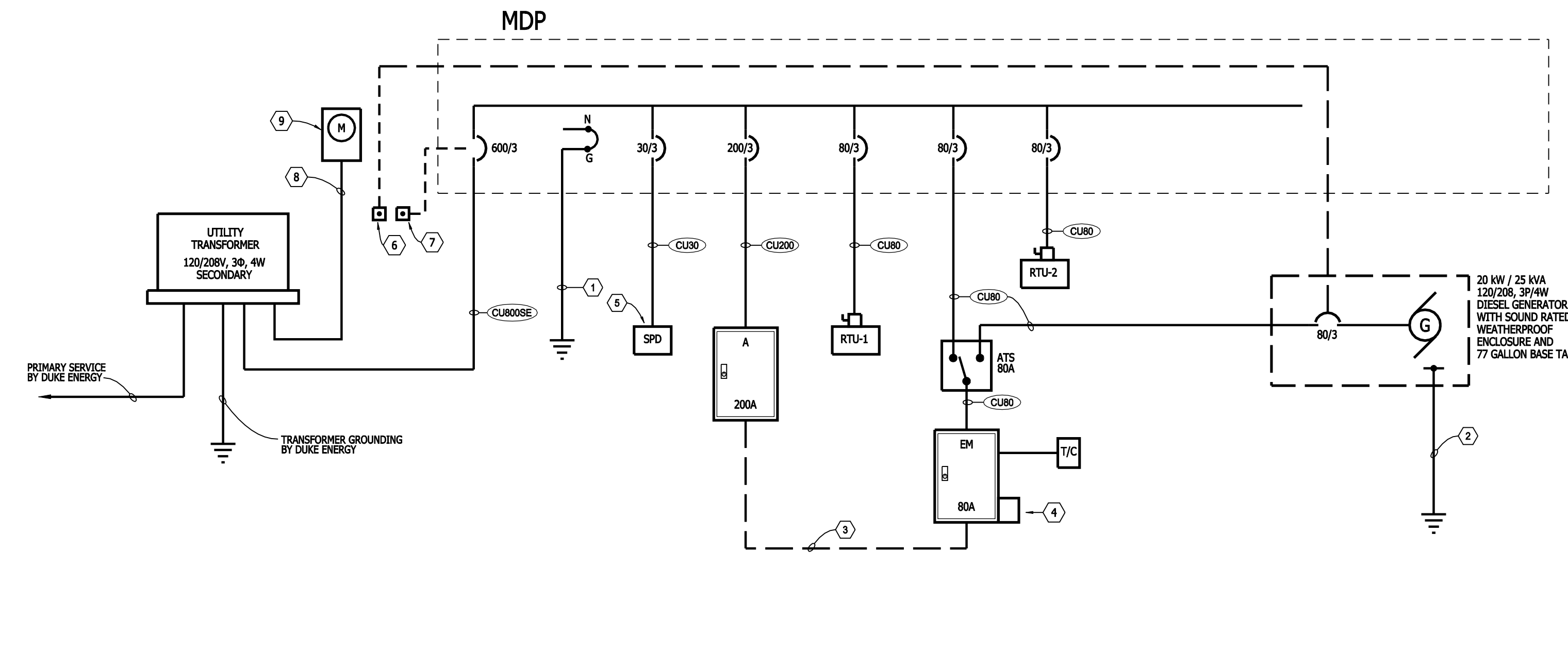

SERVICE LOAD CALCULATION table with columns for Panel, Lights, Recept, HVAC, Equip, Kitchen, Misc, and Totals. Includes demand calculation and largest motor information.

FEEDER SIZES table listing conductor types and sizes for various circuit breakers (CU1000, CU200, CU125, CU180, CU190, CU200).

POWER RISER DIAGRAM NTS

CONTRACTOR SHALL BE RESPONSIBLE FOR PROVIDING ARC FLASH LABELS AS REQUIRED BY NFPA 70E 110.15 AND PERSONAL PROTECTIVE EQUIPMENT (PPE) RATING PLACARDS PER NFPA 70E FOR ALL NEW SWITCHGEAR.

MANUFACTURER: SQUARE D, M/O OR MICE: MJD, FEED: BOTTOM. Includes table for Panel EM with load details and demand calculations.

MANUFACTURER: SQUARE D, M/O OR MICE: MJD, FEED: BOTTOM. Includes table for Panel A with load details and demand calculations.

MANUFACTURER: SQUARE D, M/O OR MICE: MJD, FEED: BOTTOM. Includes table for Panel EM with load details and demand calculations.

- NOTES: 1. PROVIDE 1 #3/0 THW COPPER GROUNDING ELECTRODE CONDUCTOR AND BOND THE SYSTEM NEUTRAL AT THE MAIN BREAKER. 2. EQUIPMENT GROUND CONDUCTOR BOND TO GENERATOR FRAME... 3. PROVIDE PANEL BOARD BONDING IN ACCORDANCE WITH N.E.C. ARTICLE 517.14...

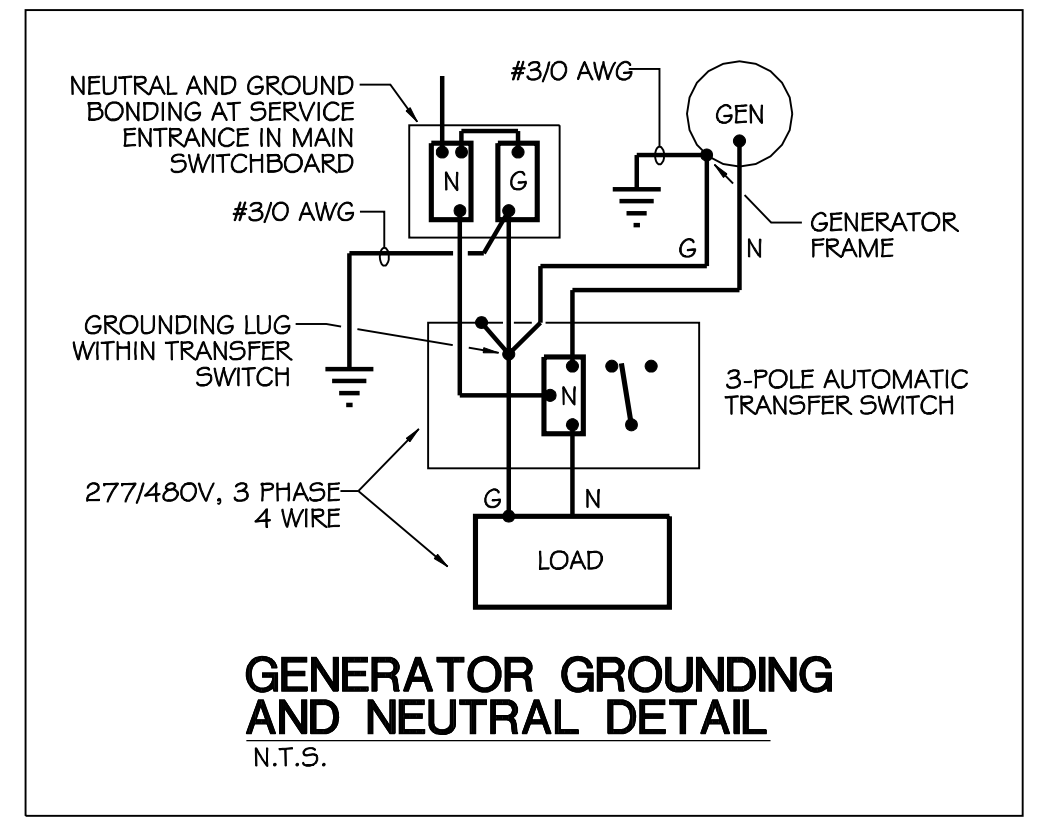

PINELLAS COUNTY BAYSIDE HEALTH CLINIC 14808 49TH STREET NORTH CLEARWATER, FLORIDA 33762 50% CONSTRUCTION DOCUMENTS

Comm. No. 14005 Date: 4/13/2015 Drawn: RDS/RMS Revised:

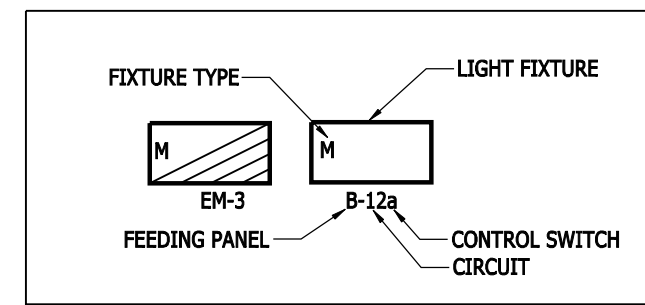

M.P. SPYCHALA & ASSOC., INC.
 CONSULTING ENGINEERS
 240 Pine Ave. N. Oldsmar FL 34677
 (813) 855-2721 FAX (813) 855-2741
 mpspychala@spychalaengineers.com

Signed & Sealed by:
 Michael P. Spychala P.E.
 No. 15153
 Exp. 04/30/17

MBA

MASON BLAU
 AND
 ASSOCIATES, INC.
 ARCHITECTS - PLANNERS
 A A 0 0 2 7 7 9

NEWPORT SQUARE
 4625 EAST BAY DRIVE
 SUITE 228
 CLEARWATER, FL
 3 3 7 6 4
 727/530-0570

GENERAL NOTES

- A. CONTRACTOR SHALL INSTALL A GREEN EQUIPMENT GROUNDING WIRE IN ALL CONDUITS AND SHALL BOND THE GROUND WIRE TO ALL DEVICES AND ELECTRICALLY WIRED EQUIPMENT. BONDING SHALL BE INSTALLED IN ACCORDANCE WITH TABLE 250-122 OF THE NEC.
- B. ALL ELECTRICAL SYSTEM WIRING FOR THE EMERGENCY GENERATING SYSTEM SHALL BE INSTALLED IN ELECTRICAL METALLIC TUBING, RIGID GALVANIZED STEEL CONDUITS OR HOSPITAL GRADE MC CABLE, TYPICAL THROUGHOUT THIS FACILITY.
- C. CONTRACTOR SHALL REFER TO ARCHITECTURAL REFLECTED CEILING PLANS FOR EXACT LOCATION OF ALL CEILING EQUIPMENT.
- D. ALL CONDUIT USED TO SUPPLY LIGHTS, WIRING DEVICES, HVAC EQUIPMENT, OR ANY OTHER LINE VOLTAGE EQUIPMENT IN PATIENT CARE AREAS OF THIS FACILITY SHALL BE STEEL CONDUIT. CONDUIT MAY BE RIGID GALVANIZED STEEL, ELECTRICAL METALLIC TUBING OR HOSPITAL GRADE MC CABLE INSTALLED IN ACCORDANCE WITH THE SPECIFICATIONS.
- E. ALL RECEPTACLES, LIGHT SWITCHES AND COVERPLATES FOR DEVICES CONNECTED TO THE EMERGENCY SYSTEM SHALL BE RED IN COLOR. TYPICAL THROUGHOUT.
- F. ALL DEVICE PLATES FOR LIGHT SWITCHES AND RECEPTACLES SHALL BE ENGRAVED WITH THE FEEDING PANEL AND CIRCUIT NUMBER (FF-FNL-CKT). CONTRACTOR SHALL SUBMIT SAMPLE TO ARCHITECT & ENGINEER FOR APPROVAL. TYPICAL THROUGHOUT THIS PROJECT.
- G. ALL OUTLET OR DEVICE BOXES INSTALLED WITHIN CEILING AREAS SHALL HAVE A MAXIMUM 1/8" GAP AROUND OUTSIDE EDGE OF CUT-OUT. SEAL ALL GAPS WITH FIRE RATED PUTTY/CALMING. PROVIDE UL LISTED EXTENSION RINGS FOR OUTLET BOXES THAT ARE NOT FLUSH WITH SURFACE. TYPICAL THROUGHOUT.
- H. A SEPARATE NEUTRAL CONDUCTOR SHALL BE RUN FOR EACH NEW BRANCH CIRCUIT WITHIN THE PROJECT AREA.

NOTES

1. SHADED FIXTURES SHALL BE WIRED TO THE EMERGENCY GENERATOR DISTRIBUTION SYSTEM. TYPICAL.
2. CEILING MOUNTED OCCUPANCY SENSORS AND POWER PACKS SHALL CONTROL LIGHTS AS INDICATED. SEE DETAILS ON SHEET E3.1.
3. PASSIVE INFRARED AUTOMATIC LIGHT SWITCH SHALL BE GREENGATE OSW-P-045 I-MV-V OR APPROVED EQUAL. PROVIDE IVORY DECORA WALL PLATE FOR LIGHTS CONNECTED TO THE NORMAL DISTRIBUTION. WALL PLATE SHALL BE ENGRAVED WITH FEEDING PANEL AND CIRCUIT NUMBER (ie. FF-FNL-CKT).
4. PASSIVE INFRARED AUTOMATIC LIGHT SWITCH SHALL BE GREENGATE OSW-P-045 I-MV-V OR APPROVED EQUAL. PROVIDE RED DECORA WALL PLATE FOR LIGHTS CONNECTED TO THE EMERGENCY SYSTEM. WALL PLATE SHALL BE ENGRAVED WITH FEEDING PANEL AND CIRCUIT NUMBER (ie. FF-FNL-CKT).

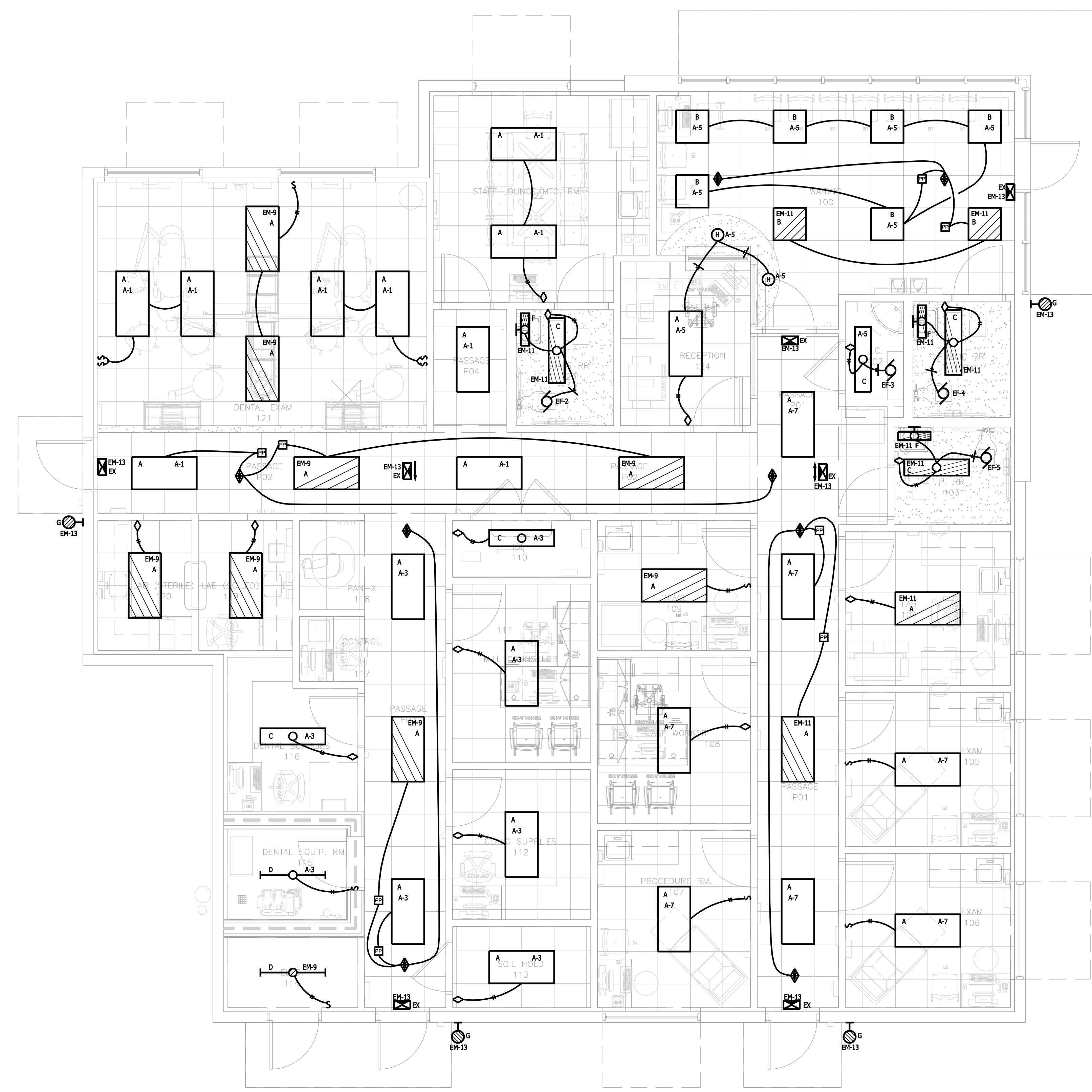

PINELLAS COUNTY
 BAYSIDE HEALTH CLINIC
 14808 49TH STREET NORTH CLEARWATER, FLORIDA 33762
 50% CONSTRUCTION DOCUMENTS

Comm. No. 14005
 Date: 4/13/2015
 Drawn: RDS/MPS
 Revised:

NORTH
LIGHTING PLAN
 1/4" = 1'-0"

E3.0



NORTH
FINISH FLOOR PLAN
1/4" = 1'-0"

FINISH SCHEDULE										
ROOM #	ROOM NAME	FLOOR	BASE	WALLS				UPPER / LOWER COUNTER CABINETS SURFACE	REMARKS	
				NORTH	EAST	SOUTH	WEST			
100	WAITING	LV1	VC1	RE1	RE1	GE1,GE2	GE1,GE2	PL1	SS1	1,2
101	PUBLIC RR	PT1	--	PT1,PT2	PT1,PT2	PT1,PT2	PT1,PT2			3
102	J.C.	PT1	PT3	GE1	GE1	GE1	GE1			
103	P. RR	PT1	--	PT1,PT2	PT1,PT2	PT1,PT2	PT1,PT2			3
104	LAB	LV1	VC1	GE1	RE1	GE1	GE1	PL1	SS1	
105	EXAM	LV1	VC1	GE1	RE1	GE1	GE1	PL1	SS1	
106	EXAM	LV1	VC1	GE1	RE1	RE1	GE1	PL1	SS1	
107	PROCEDURE RM.	LV1	VC1	GE1	GE1	RE1	GE1	PL1	SS1	
108	CASE WORKER	LV1	VC1	GE1	GE1	GE1	GE1	PL1	SS1	
109	TRIAGE	LV1	VC1	GE1	GE1	GE1	GE1	PL1	SS1	
110	DP	LV1	VC1	GE1	GE1	GE1	GE1			
111	M.H. COUNSELOR	LV1	VC1	GE1	GE1	GE1	GE1	PL1	SS1	
112	CLINIC SUPPLIES	LV1	VC1	GE1	GE1	GE1	GE1			
113	SOIL HOLD	LV1	VC1	GE1	GE1	RE1	GE1			
114	ELEC.	CS	VC1	GE1	GE1	RE1	RE1			
115	DENTAL EQUIP. RM.	LV1	VC1	GE1	GE1	GE1	GE1			
116	DENTAL SUPPLIES	LV1	VC1	GE1	GE1	GE1	GE1			
117	CONTROL	LV1	VC1	GE1	--	GE1	GE1	PL1	SS1	
118	PAN-X	LV1	VC1	GE1	--	GE1	GE1			
119	LAB (SOILED)	LV1	VC1	GE1	RE1,GE1	GE1	GE1	PL1	SS1	
120	LAB (STERILE)	LV1	VC1	GE1	RE1	RE1	PL1	SS1		
121	DENTAL EXAM	LV1	VC1	RE1	GE2	--	RE2			1,2
122	STAFF LOUNGE/MTC. RM.	LV1	VC1	RE1	GE1	GE1	RE2,GE2	PL1	SS1	1
123	STAFF RR	PT1	--	PT1,PT2	PT1,PT2	PT1,PT2	PT1,PT2			3
124	RECEPTION	LV1	VC1	GE1	GE1	GE1	GE1	PL1	SS1	
P01	PASSAGE	LV1	VC1	GE1	GE1	RE1	GE1,GE3			1
P02	PASSAGE	LV1	VC1	GE	GE	GE1,GE3	RE			1
P03	PASSAGE	LV1	VC1	--	GE3	RE	GE			1
P04	PASSAGE	LV1	VC1	GE1	GE1	--	GE2			1

MATERIAL LEGEND	
FLOOR MATERIALS	WALL MATERIALS
LV1 MANUF.: SPACIA CONTACT/TERESA FINCH(813) COLOR: 555A6140 MIRUS INDIGO SIZE: 4"x5"	GP1 MANUF.: SHERWIN WILLIAMS COLOR: NAVAJO WHITE SW6126
PT1 MANUF.: DALTILE SERIES: CONTINENTAL SLATE COLOR: 556 TUSCAN BLUE SIZE: 12x18 GROUT: MAPEL EPOXY,19 PEARL GRAY	GP2 MANUF.: SHERWIN WILLIAMS COLOR: EBBTIDE SW6493
CS SEALED CONCRETE	P4 MANUF.: SHERWIN WILLIAMS COLOR: SOFTWARE SW7074
CABINETS/ COUNTER SURFACES	GP5 MANUF.: SHERWIN WILLIAMS COLOR: PURE WHITE SW7005
PL1 MANUF.: WILSONART LAMINATE CONTACT/TERESA FINCH(813) COLOR: 4941K-18 COSMIC STRANDZ	PT1 MANUF.: DALTILE SERIES: CONTINENTAL SLATE COLOR: 556 TUSCAN BLUE SIZE: 12x18 GROUT: MAPEL EPOXY,19 PEARL GRAY
SS1 MANUF.: WILSONART SOLID SURFACE CONTACT/TERESA FINCH(813) COLOR: FOSSIL RIVERSTONE	PT2 MANUF.: DALTILE SERIES: CONTINENTAL SLATE CS74 GOLD/BLUE/BROWN SIZE: 4X12 DECO GROUT: MAPEL EPOXY,19 PEARL GRAY
MISCELLANEOUS MATERIALS	PT3 MANUF.: DALTILE SERIES: CONTINENTAL SLATE COLOR: 556 TUSCAN BLUE SIZE: 3X12 BULLNOSE S-43C9 GROUT: MAPEL EPOXY,19 PEARL GRAY
CG1 MANUF.: MANNINGTON COLOR: 808 IRON PROFILE: 691 2.5"	BASE MATERIALS
DF1 MANUF.: MARSHFIELD SPECIES: WHITE BIRCH FINISH: BOMBAY 64-02	VC1 MANUF.: MANNINGTON COLOR: 808 IRON SIZE: 4" TRADITIONAL, 1/8" THICK
WT1 MANUF.: HUNTER DOUGLAS CONTRACT FABRIC: SHEERWEAVE 2410 3% OPEN COLOR: OYSTER/PEARL GRAY	

- FINISH GENERAL NOTES**
1. ALL GYPSUM CEILINGS TO BE PAINTED GE5 UNLESS OTHERWISE NOTED.
 2. ALL DOOR FRAMES TO BE PAINTED COLOR GE4 UNLESS OTHERWISE NOTED.
 3. ALL CORNER GUARDS TO BE CG1.
 4. INSTALL VINYL PLANK (W1) EAST TO WEST IN STAGGERED PATTERN.
 5. ALL DOORS TO BE DF1 UNLESS OTHERWISE NOTED.
 6. ALL ROLLER SHADES/WINDOW TREATMENTS TO BE WT1.

- FINISH REMARKS**
1. SEE FINISH FLOOR PLAN FOR MORE INFORMATION ABOUT ACCENT WALL LOCATIONS.
 2. SOFFIT/HEADER TO BE PAINTED GE2.
 3. SEE 1. INTERIOR ELEVATION, 2. INTERIOR ELEVATION AND 3. FLOORING PATTERN DETAIL ON SHEET ID-1 FOR MORE INFORMATION.

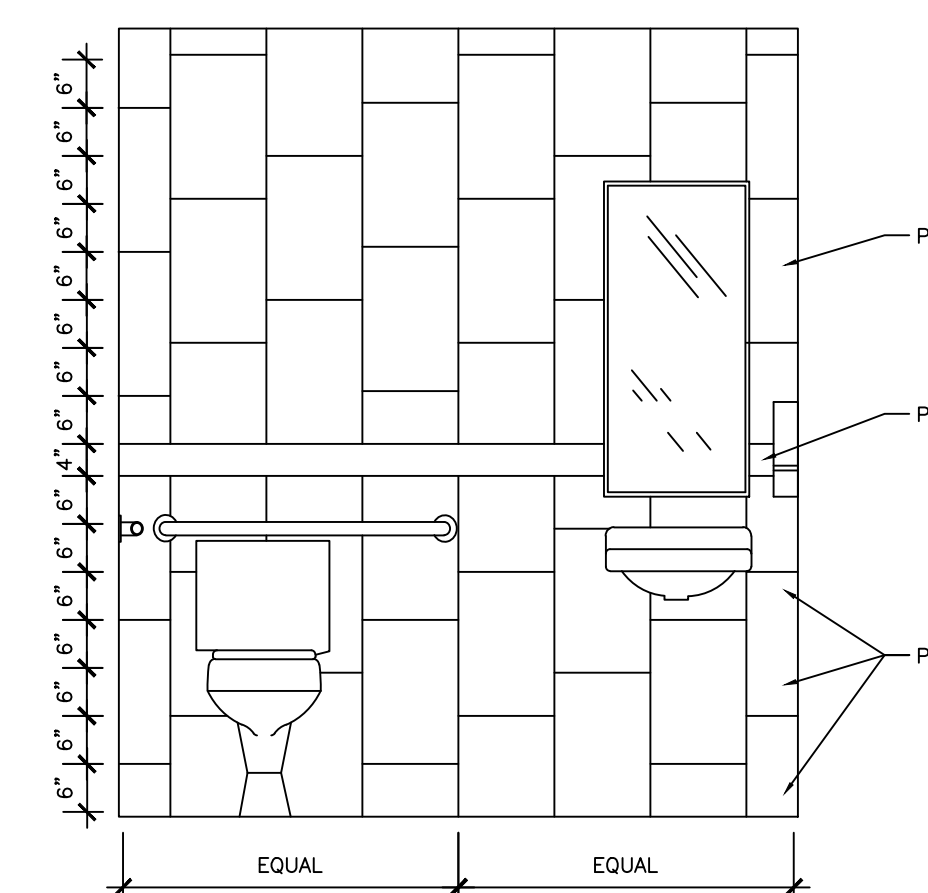

1. INTERIOR ELEVATION
1/2" = 1'-0"

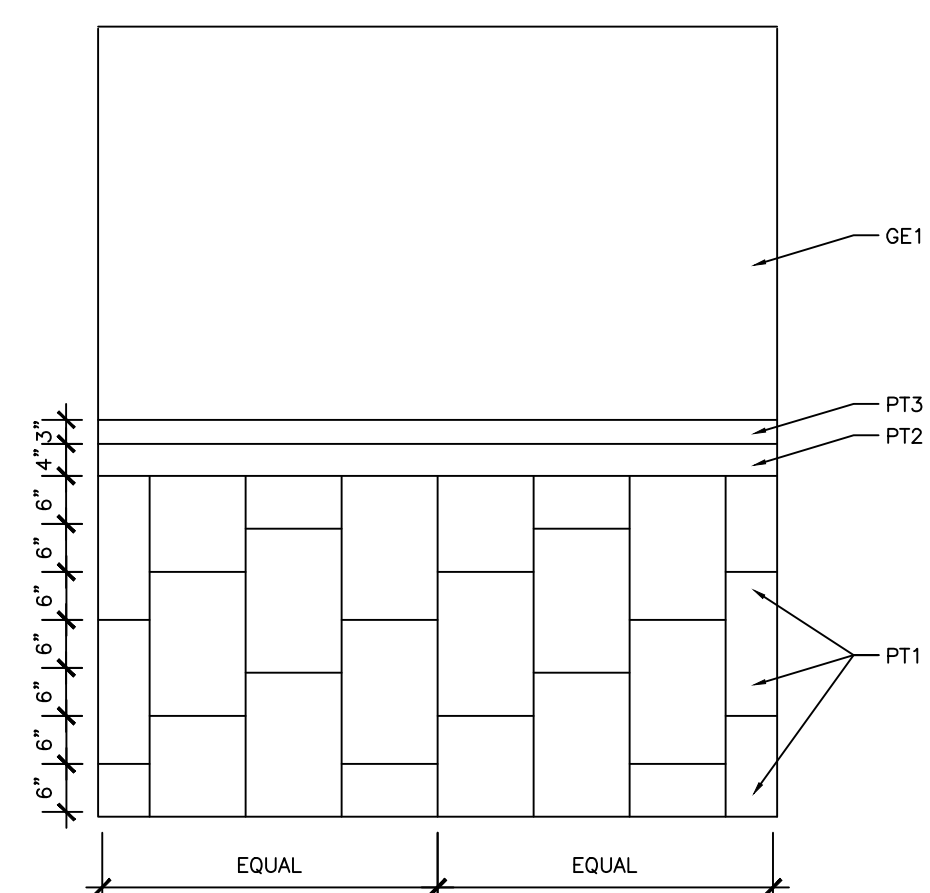

2. INTERIOR ELEVATION
1/2" = 1'-0"

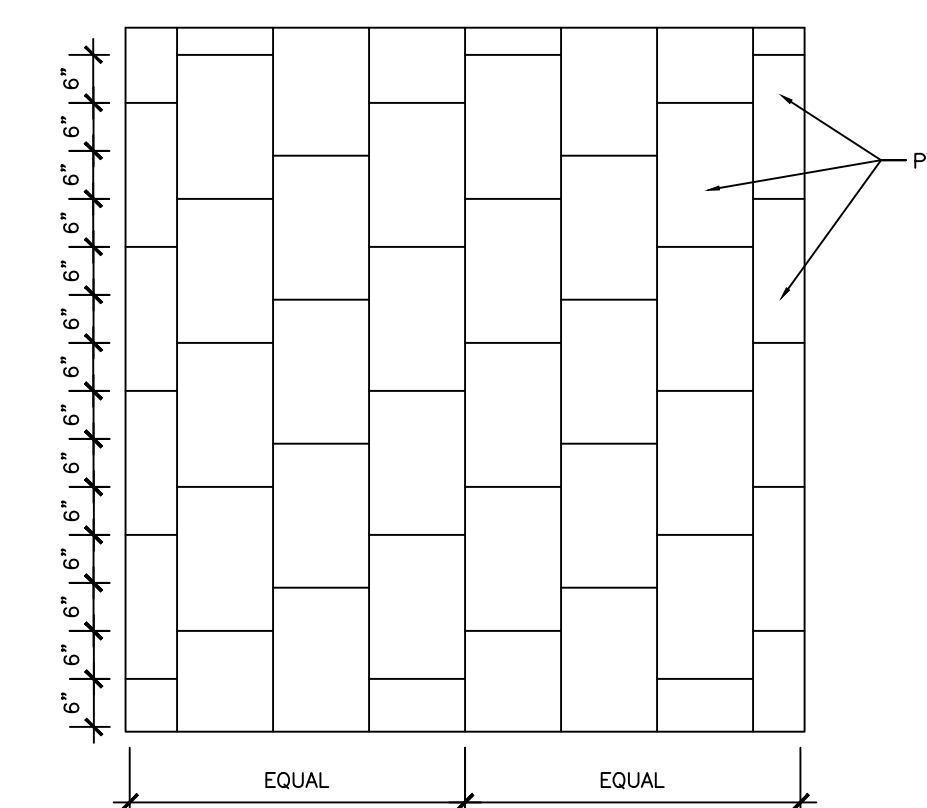

3. FLOORING PATTERN DETAIL
1/2" = 1'-0"

Signed & Sealed by:
Michael L. Forley, LEED AP
P.E. No. 100000000
FL No. 100000000
Exp. 03/1/2025

MBA
MASON BLAU
AND
ASSOCIATES, INC.
ARCHITECTS, PLANNERS
A A 0 0 2 7 9

NEWPORT SQUARE
4625 EAST BAY DRIVE
SUITE 228
CLEARWATER, FL
3 3 7 6 4

727/530-0570

PINELLAS COUNTY
BAYSIDE HEALTH CLINIC
14808 49TH STREET NORTH CLEARWATER, FLORIDA 33762
50% CONSTRUCTION DOCUMENTS

Comm. No. 14005
Date: 4/13/2015
Drawn: MLE
Revised:



Radio Handout - APX 1000 Radio

Model Number H84UCD9PW5AN
Serial Number 837CSF0044
FLASHcode 901048-G11488-6



Buttons and Controls

Index	Description	Conventional	Trunking	
1	Multi-Function Knob	Power	Power	
		Primary Function	Volume Select	Volume Select
		Secondary Function	Channel Select	Channel Select
2	Top Button	Unprogram med	Unprogram med	
3	Side Top Button	Light/Flip	Light/Flip	
4	Side Middle Button	TalkAround/ Direct	Nuisance Delete	
5	Side Bottom Button	Monitor	Scan	

Zones and Channels

Channels	Zone1	Zone2	Zone3
1	PCHS-1	PCW-1	
2	PCHS-2	PCW-2	
3		EOC-A	
4		EOC-B	
5		EOC-C	

Our Products Your Industry About Us SDS

Home > Products > Clorox® > Clorox Commercial Solutions® Clorox® Total 360® System

Product Catalog

Clorox® Total 360® System

Superior Electrostatic Coverage with Trusted Clorox® Products
for an Award-Winning Disinfecting Solution



Clorox® Total 360® System

At a Glance Efficacy Usage SDS Cold & Flu Solutions FAQs Videos

Get Superior Coverage with Clorox® Total 360®

Ready to Buy?

Contact us at devices@clorox.com or call 1-800-492-9729.

Save Up to \$100

Get your rebate for select cleaning and maintenance products from Clorox Commercial Solutions®.

[Download Rebate](#)

Request a Demo

Please fill out the form below and a Clorox Broker will contact you to schedule a demo or answer additional questions.

Name

Title

Email

Phone

Organization

City

State

Current Distributor

Quick Facts

The Cost-Effective Solution for Superior Surface Coverage

The revolutionary Clorox® Total 360® System is an electrostatic sprayer paired with Clorox® trusted solutions. It provides superior coverage through proven electrostatic technology and delivers Clorox® disinfectants and sanitizers onto hard-to-reach surfaces. The Clorox® Total 360® System helps keep your facility healthier while also saving you time, money and labor.

- Saves time: Works up to 4x faster*
- Saves labor: Covers up to 18,000 ft²/hour
- Saves money: Uses up to 65% less solution*

Why the Boston Red Sox Trust the Clorox® Total 360® System

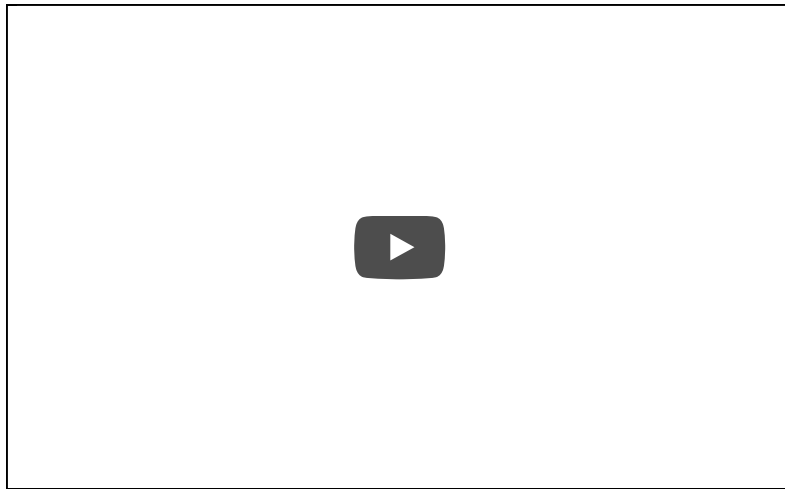

Submit

Sign Up for News

Receive industry insights, toolkits or product sample offers right in your inbox!

Subscribe Today

“When we first received the Clorox® Total 360® System, we were in the midst of a flu outbreak. One quarter of the elementary school students were sent home with the flu. **We used the Clorox® Total 360® System on a Thursday night, and all of the students returned to the school Monday morning with no illnesses. We have been outbreak free since.**”



—Richard Wagner, building and grounds director, Palmyra-Eagle Area School District, Palmyra, WI

Introduction to Clorox® Total 360® Electrostatic Technology

Electrostatic technology enables superior coverage of Clorox-trusted solutions in hard-to-reach places—the side, underside and backside of surfaces.

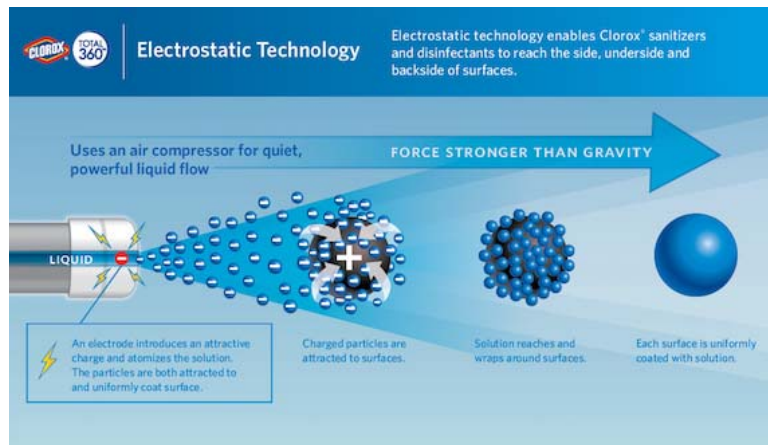

Public Relations Support

With your investment in the Clorox® Total 360® System, Clorox Professional will partner with you to help inform internal and external audiences, as well as the broader community, about your facility's superior cleaning protocols and effort to reduce germs and prevent illnesses.

Clorox Professional's public relations team can help you:

- Generate local media coverage that highlights your investment in the Clorox® Total 360® System and the efforts you are making to prevent illness-related outbreaks.

Share information, answer frequently asked questions and guide conversations about your use of the Clorox® Total 360® System.

For more information or to get started, contact Clorox Professional's public relations team at CloroxTotal360PR@ketchum.com. Please include your contact information, facility name and sales representative's name.

Customer Support

Get device service and troubleshooting support [here](#).

For all other questions about your Clorox® Total 360® System, call 1-800-492-9729 or [contact us](#).

Warranty

Two-year warranty from manufacturer ship date

Additional extended warranties available for purchase

Support for the Clorox® Total 360® System

Necessary parts and labor to restore equipment to its proper operating condition

Register your product to activate your warranty

* Compared with a trigger spray.

Related Products

Clorox Commercial Solutions®

**Clorox®
Disinfecting Wipes**
[See It](#)

Clorox Commercial Solutions®

Clorox® Urine Remover
[See It](#)

We are your trusted advisor.

See how we can help in your industry:

- Healthcare
- Cleaning & Maintenance
- Foodservice

Site Links

- Home
- Our Products
- Sign Up for News
- About Us
- How to Buy
- Newsroom
- TouchPoint
- SDS
- Contact Us
- Site Map

© 2018 The Clorox Company

- Terms of Use
- Privacy Policy
- The Clorox Company
- Clorox Professional Canada
- AdChoices

**VERITIV PROPOSAL FOR PINELLAS COUNTY DEPARTMENT OF HEALTH
ATTN: ASHLEY HOSKINS
205 DR. MARTIN LUTHER KING JR. ST. NORTH
ST. PETERSBURG FL 33701**

3 EACH

Item:10922311 CLOROX T360 SPRAYER

MFG#: 60010

\$3,999.0000EACH

2 CASES

Item:10917882 CLOROX TOTAL 360 DISINFECTANT

MFG#: 31650

4-1 GALLON

\$92.88 CASE

1 CASE

Item: 10917884 CLOROX TOTAL 360 SANITIZER

MFG#: 31651

4-1 GALLON

\$92.88 CASE

LEAD TIME 10-12 DAYS

FRED BYRD

VERITIV

6870 FIRST PARK BLVD

LAKELAND FLORIDA 33610