

CYPRESS RUN - UNIT III

A RE-PLAT OF A PORTION OF TRACT "L" OF CYPRESS RUN - UNIT II

AS RECORDED IN PLAT BOOK 87, PAGE 65 OF THE PUBLIC RECORDS OF PINELLAS COUNTY, FLORIDA

LOCATED IN SECTION 9, TOWNSHIP 27 SOUTH, RANGE 16 EAST

PINELLAS COUNTY, FLORIDA

DESCRIPTION:

BEING A PORTION OF TRACT "L" OF CYPRESS RUN - UNIT II AS RECORDED IN PLAT BOOK 87, PAGE 65 OF THE PUBLIC RECORDS OF PINELLAS COUNTY, FLORIDA

BEGIN AT THE SOUTHEAST CORNER OF SAID TRACT "L", SAID POINT BEING A BEGINNING OF A CURVE CONCAVE NORTHERLY AND HAVING A RADIUS OF 496.98 FEET; THENCE CONTINUE ALONG THE SOUTHERLY LINE OF SAID TRACT "L" AND THE ARC OF SAID CURVE TO THE RIGHT A DISTANCE OF 127.16 FEET, SAID CURVE HAVING A CHORD DISTANCE AND BEARING OF 126.81 FEET, N 86°38'05" W TO A POINT OF TANGENCY; THENCE CONTINUE ALONG THE SOUTHERLY LINE OF SAID TRACT "L" N 79°18'17" W, A DISTANCE OF 137.75 FEET TO A POINT OF CURVATURE OF A CURVE CONCAVE NORTHEASTERLY AND HAVING A RADIUS OF 145.00 FEET; THENCE CONTINUE ALONG THE SOUTHERLY LINE OF SAID TRACT "L" AND THE ARC OF SAID CURVE TO THE RIGHT A DISTANCE OF 194.37 FEET, SAID CURVE HAVING A CHORD DISTANCE AND BEARING OF 180.14 FEET, N 40°54'08" W TO A POINT OF TANGENCY; THENCE ALONG THE WESTERLY LINE OF SAID TRACT "L" N 02°30'00" W, A DISTANCE OF 48.00 FEET TO A POINT OF CURVATURE OF A CURVE CONCAVE WESTERLY AND HAVING A RADIUS OF 470.00 FEET; THENCE CONTINUE ALONG THE WESTERLY LINE OF SAID TRACT "L" AND THE ARC OF SAID CURVE TO THE LEFT A DISTANCE OF 7.83 FEET, SAID CURVE HAVING A CHORD DISTANCE AND BEARING OF 7.83 FEET, N 02°58'37" W; THENCE S 89°53'21" E, A DISTANCE OF 126.31 FEET; THENCE S 00°07'24" E, A DISTANCE OF 40.00 FEET; THENCE S 89°53'21" E, A DISTANCE OF 100.88 FEET; THENCE S 83°49'50" E, A DISTANCE OF 144.25 FEET TO A POINT ON THE EASTERLY LINE OF SAID TRACT "L"; THENCE S 03°57'52" E ALONG THE EASTERLY LINE OF SAID TRACT "L", A DISTANCE OF 169.40 FEET TO THE POINT OF BEGINNING.

CONTAINING 1.422 ACRES, MORE OR LESS

DEDICATION:

CYPRESS RUN OF FLORIDA, LLC, A FLORIDA LIMITED LIABILITY COMPANY, HEREBY CERTIFIES THAT IT IS THE OWNER IN FEE SIMPLE OF THE LANDS DESCRIBED ON THIS PLAT AND THAT SAID LANDS ARE HEREBY PLATTED AS "CYPRESS RUN - UNIT III.

ALL EASEMENTS DEDICATED BY THIS PLAT ARE INTENDED FOR THE USE DESCRIBED HEREON. THE PRIVATE DRAINAGE AND INGRESS/EGRESS EASEMENTS SHOWN ON THIS PLAT, ARE NOT DEDICATED FOR THE USE OF THE PUBLIC IN GENERAL, EXCEPT AS NOTED HEREIN AFTER, BUT ARE DEDICATED TO CYPRESS RUN RAILROAD PROPERTY, LLC, A FLORIDA LIMITED LIABILITY COMPANY AND FOR THE COMMON USE AND BENEFIT OF THE OWNERS OF THE LOTS SHOWN ON THIS PLAT, THEIR SUCCESSORS AND/OR ASSIGNS.

THE PRIVATE DRAINAGE EASEMENTS SHOWN ON THIS PLAT ARE FOR INGRESS, EGRESS, INCLUDING LOCAL DRAINAGE SYSTEMS AND ARE CREATED FOR THE COMMON USE AND BENEFIT OF THE OWNERS OF THE LOTS, THEIR SUCCESSORS AND/OR ASSIGNS. THE MAINTENANCE, AND OPERATION OF THE FACILITIES WITHIN THE PRIVATE DRAINAGE EASEMENTS SHALL BE THE RESPONSIBILITY OF THE OWNERS OF THE LOTS AND/OR CYPRESS RUN RAILROAD PROPERTY, LLC, THEIR SUCCESSORS AND/OR ASSIGNS.

THE OWNER DOES HEREBY DEDICATE TO THE PUBLIC ALL EASEMENTS DESIGNATED ON THE PLAT AS PUBLIC OR UTILITY EASEMENTS.

OWNER:

CYPRESS RUN OF FLORIDA, LLC,
A FLORIDA LIMITED LIABILITY COMPANY
DUANE VAN ETTEN

BY: DUANE VAN ETTEN
DUANE VAN ETTEN
AUTHORIZED MEMBER

MARK ALAN QUINN
WITNESS
MARK ALAN QUINN
WITNESS PRINT NAME
LEXA RAMOS
WITNESS
LEXA RAMOS
WITNESS PRINT NAME

ACKNOWLEDGEMENT:

STATE OF FLORIDA
COUNTY OF PINELLAS

BEFORE ME, THE UNDERSIGNED AUTHORITY, BY MEANS OF PHYSICAL PRESENCE OR ONLINE NOTARIZATION, PERSONALLY APPEARED DUANE VAN ETTEN AS AUTHORIZED MEMBER OF CYPRESS RUN OF FLORIDA, LLC, A FLORIDA LIMITED LIABILITY COMPANY, AND HAS PRODUCED _____ AS IDENTIFICATION AND KNOWN TO ME TO BE THE PERSON EXECUTING THE FOREGOING DEDICATION AND HE ACKNOWLEDGED TO ME THAT HE EXECUTED THE SAME FOR THE PURPOSES SET OUT THEREIN.

WITNESS BY MY HAND AND OFFICIAL SEAL THIS 16th DAY OF June, 2023.
NOTARY PUBLIC Sylvie Croland
NAME OF NOTARY (PRINTED OR STAMPED)
STATE OF FLORIDA AT LARGE.



CONFIRMATION OF ACCEPTANCE:

CYPRESS RUN RAILROAD PROPERTY, LLC, A FLORIDA LIMITED LIABILITY COMPANY JOINS IN THE DEDICATION FOR THE PURPOSE OF ACCEPTING THE PRIVATE DRAINAGE AND INGRESS/EGRESS EASEMENTS AS SHOWN ON THIS PLAT. CYPRESS RUN RAILROAD PROPERTY, LLC ACCEPTS THE OPERATION AND MAINTENANCE RESPONSIBILITY WITHIN THE PRIVATE DRAINAGE AND INGRESS/EGRESS EASEMENTS

CYPRESS RUN RAILROAD PROPERTY, LLC,
A FLORIDA LIMITED LIABILITY COMPANY
DUANE VAN ETTEN

BY: DUANE VAN ETTEN
DUANE VAN ETTEN
AUTHORIZED MEMBER

MARK ALAN QUINN
WITNESS
MARK ALAN QUINN
WITNESS PRINT NAME
LEXA RAMOS
WITNESS
LEXA RAMOS
WITNESS PRINT NAME

ACKNOWLEDGEMENT:

STATE OF FLORIDA
COUNTY OF PINELLAS

BEFORE ME, THE UNDERSIGNED AUTHORITY, BY MEANS OF PHYSICAL PRESENCE OR ONLINE NOTARIZATION, PERSONALLY APPEARED DUANE VAN ETTEN AS AUTHORIZED MEMBER OF CYPRESS RUN RAILROAD PROPERTY, LLC, A FLORIDA LIMITED LIABILITY COMPANY, AND HAS PRODUCED _____ AS IDENTIFICATION AND KNOWN TO ME TO BE THE PERSON EXECUTING THE FOREGOING DEDICATION AND HE ACKNOWLEDGED TO ME THAT HE EXECUTED THE SAME FOR THE PURPOSES SET OUT THEREIN.

WITNESS BY MY HAND AND OFFICIAL SEAL THIS 16th DAY OF June, 2023.
NOTARY PUBLIC Sylvie Croland
NAME OF NOTARY (PRINTED OR STAMPED)
STATE OF FLORIDA AT LARGE.

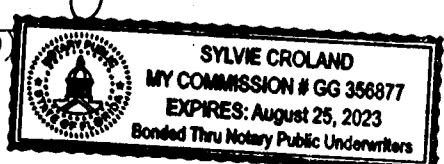

NOTICE:

THIS PLAT, AS RECORDED IN ITS GRAPHIC FORM, IS THE OFFICIAL DEPICTION OF THE SUBDIVIDED LANDS DESCRIBED HEREIN AND WILL IN NO CIRCUMSTANCES BE SUPPLANTED IN AUTHORITY BY ANY OTHER GRAPHIC OR DIGITAL FORM OF THE PLAT. THERE MAY BE ADDITIONAL RESTRICTIONS THAT ARE NOT RECORDED ON THIS PLAT THAT MAY BE FOUND IN THE PUBLIC RECORDS OF PINELLAS COUNTY.

ALL PLATTED PUBLIC UTILITY EASEMENTS SHALL PROVIDE THAT SUCH EASEMENTS SHALL ALSO BE EASEMENTS FOR THE CONSTRUCTION, INSTALLATION, MAINTENANCE, AND OPERATION OF CABLE TELEVISION SERVICES; PROVIDED, HOWEVER, NO SUCH CONSTRUCTION, INSTALLATION, MAINTENANCE, AND OPERATION OF CABLE TELEVISION SERVICES SHALL INTERFERE WITH THE FACILITIES AND SERVICES OF AN ELECTRIC, TELEPHONE, GAS, OR OTHER PUBLIC UTILITY. IN THE EVENT A CABLE TELEVISION COMPANY DAMAGES THE FACILITIES OF A PUBLIC UTILITY, IT SHALL BE SOLELY RESPONSIBLE FOR THE DAMAGES. THIS SECTION SHALL NOT APPLY TO THOSE PRIVATE EASEMENTS GRANTED TO OR OBTAINED BY A PARTICULAR ELECTRIC, TELEPHONE, GAS, OR OTHER PUBLIC UTILITY. SUCH CONSTRUCTION, INSTALLATION, MAINTENANCE, AND OPERATION SHALL COMPLY WITH THE NATIONAL ELECTRICAL SAFETY CODE AS ADOPTED BY THE FLORIDA PUBLIC SERVICE COMMISSION.

NOTE:

BASIS OF BEARINGS: THE BEARINGS ARE BASED ON THE EAST LINE OF TRACT "L" AS BEING SOUTH 03°57'52" EAST AS SHOWN ON THE PLAT OF CYPRESS RUN - UNIT II AS RECORDED IN PLAT BOOK 87, PAGE 65 OF THE PUBLIC RECORDS OF PINELLAS COUNTY, FLORIDA.

CERTIFICATE OF APPROVAL OF COUNTY COMMISSION

STATE OF FLORIDA
COUNTY OF PINELLAS

IT IS HEREBY CERTIFIED THAT THIS PLAT HAS BEEN OFFICIALLY APPROVED FOR RECORD BY THE BOARD OF COUNTY COMMISSIONERS OF THE COUNTY OF PINELLAS, FLORIDA, THIS 16th DAY OF July, 2023.

APPROVED: Janet Chong
CHAIRMAN, BOARD OF COUNTY COMMISSIONERS
KEN BURKE, CLERK
PINELLAS COUNTY, FLORIDA

BY: Deputy Clerk
DEPUTY CLERK

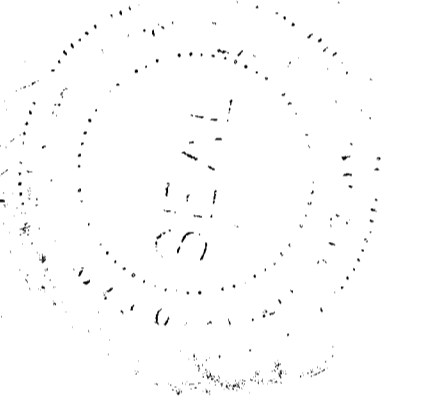

CERTIFICATE OF APPROVAL OF COUNTY CLERK

STATE OF FLORIDA
COUNTY OF PINELLAS

I, KEN BURKE, CLERK OF THE CIRCUIT COURT OF PINELLAS COUNTY, FLORIDA, HEREBY CERTIFY THAT THIS PLAT HAS BEEN EXAMINED AND THAT IT COMPLIES IN FORM WITH ALL THE REQUIREMENTS OF THE STATUTES OF THE STATE OF FLORIDA PERTAINING TO MAPS AND PLATS, AND THAT THIS PLAT HAS BEEN FILED FOR RECORD IN PLAT BOOK 146 PAGE(S) 77-78, OF THE PUBLIC RECORDS OF PINELLAS COUNTY, FLORIDA, THIS 4 DAY OF August 2023.

KEN BURKE, CLERK
PINELLAS COUNTY, FLORIDA

BY: Jeanette
DEPUTY CLERK

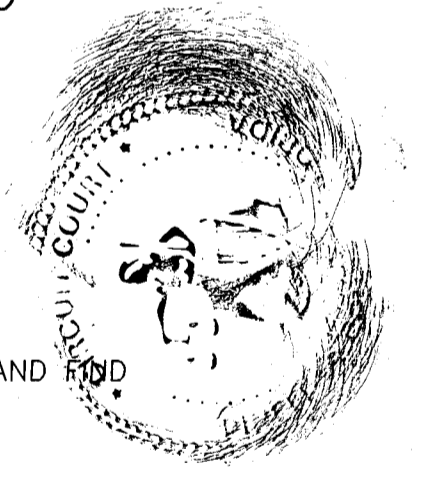

CERTIFICATE OF CONFORMITY:

REVIEWED FOR CONFORMITY TO CHAPTER 177, PART 1, FLORIDA STATUTES

I HEREBY CERTIFY THAT, PURSUANT TO CHAPTER 177.08(1), FLORIDA STATUTES, I HAVE REVIEWED THIS PLAT AND FOUND THAT IT CONFORMS TO CHAPTER 177, PART 1, FLORIDA STATUTES.

George A Shimp III
GEORGE A. SHIMP III
FLORIDA PROFESSIONAL SURVEYOR & MAPPER NO. 6137
PINELLAS COUNTY SURVEY AND MAPPING DIVISION
DEPARTMENT OF PUBLIC WORKS
22211 U.S. HIGHWAY 19 NORTH
CLEARWATER, FL 33765

6/20/2023
DATE

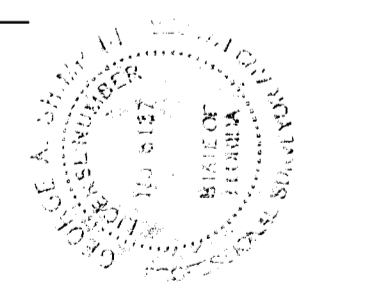

SURVEYOR'S CERTIFICATE:

I CERTIFY THAT THIS PLAT WAS PREPARED UNDER MY RESPONSIBLE DIRECTION AND SUPERVISION; THAT THIS PLAT AND THE SURVEY DATA HEREON COMPLY WITH ALL THE SURVEY REQUIREMENTS OF CHAPTER 177, FLORIDA STATUTES; THAT THIS PLAT MEETS ALL MATERIAL IN COMPOSITION REQUIRED BY 177.091, FLORIDA STATUTES; THAT THIS PLAT IS A TRUE AND CORRECT REPRESENTATION OF THE LANDS SURVEYED AND THAT THE SURVEY WAS MADE UNDER MY RESPONSIBLE DIRECTION AND SUPERVISION; AND THAT PERMANENT REFERENCE MONUMENTS (PRM'S) HAVE BEEN SET BEFORE RECORDING OF THIS PLAT AND THAT ALL LOT CORNERS WILL BE SET AS REQUIRED BY LAW. NOT VALID WITHOUT THE ORIGINAL SIGNATURE AND EMBOSSED SEAL OF A FLORIDA REGISTERED PROFESSIONAL SURVEYOR AND MAPPER.

Mark Alan Quinn
MARK ALAN QUINN
FLORIDA REGISTERED LAND SURVEYOR NO. 5850
CUMBEY & FAIR, INC.
2463 ENTERPRISE ROAD
CLEARWATER, FLORIDA 33763
LICENSE BUSINESS NO. 2168
727-797-8982

16 Jun 23
SIGNED THIS DATE

CUMBEY & FAIR, INC.
L.B #2168
2463 ENTERPRISE ROAD
CLEARWATER, FLORIDA 33763
(727) 797-8982
J.N. 2002.07 SHEET 1 OF 2

CYPRESS RUN - UNIT III

A RE-PLAT OF A PORTION OF TRACT "L" OF CYPRESS RUN - UNIT II AS RECORDED IN PLAT BOOK 87, PAGE 65 OF THE PUBLIC RECORDS OF PINELLAS COUNTY, FLORIDA LOCATED IN SECTION 9, TOWNSHIP 27 SOUTH, RANGE 16 EAST PINELLAS COUNTY, FLORIDA

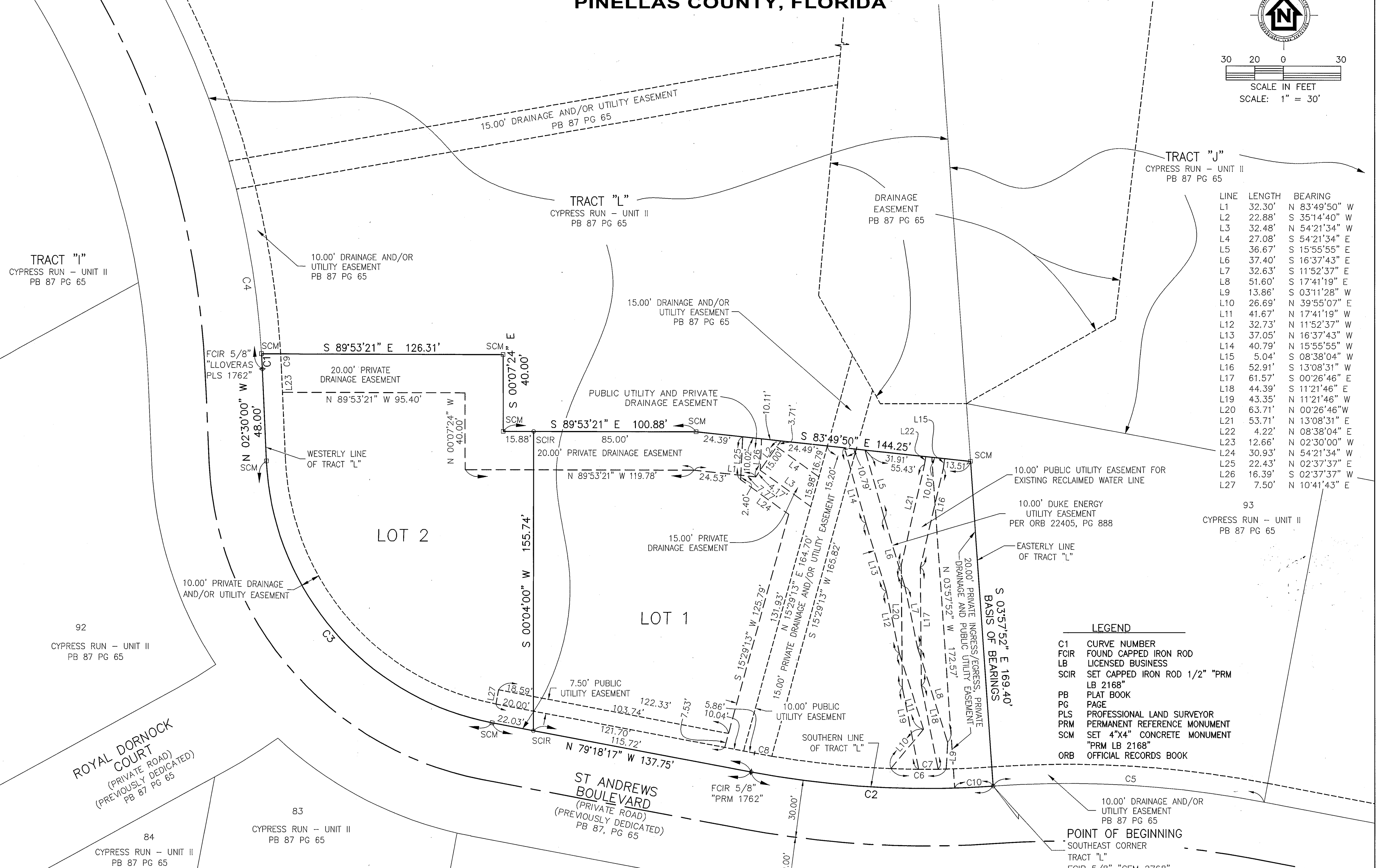
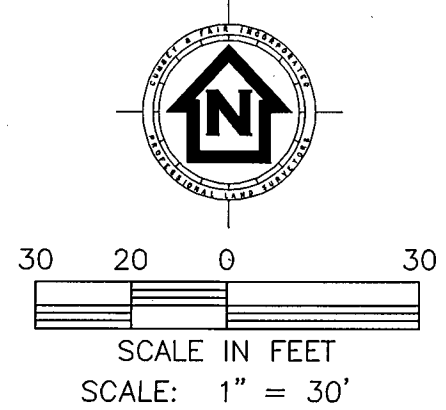

LINE	LENGTH	BEARING
L1	32.30'	N 83°49'50" W
L2	22.88'	S 35°14'40" W
L3	32.48'	N 54°21'34" W
L4	27.08'	S 54°21'34" E
L5	36.67'	S 15°55'55" E
L6	37.40'	S 16°37'43" E
L7	32.63'	S 11°52'37" E
L8	51.60'	S 17°41'19" E
L9	13.86'	S 03°11'28" W
L10	26.69'	N 39°55'07" E
L11	41.67'	N 17°41'19" W
L12	32.73'	N 11°52'37" W
L13	37.05'	N 16°37'43" W
L14	40.79'	N 15°55'55" W
L15	5.04'	S 08°38'04" W
L16	52.91'	S 13°08'31" W
L17	61.57'	S 00°26'46" E
L18	44.39'	S 11°21'46" E
L19	43.35'	N 11°21'46" W
L20	63.71'	N 00°26'46" W
L21	53.71'	N 13°08'31" E
L22	4.22'	N 08°38'04" E
L23	12.66'	N 02°30'00" W
L24	30.93'	N 54°21'34" W
L25	22.43'	N 02°37'37" E
L26	16.39'	S 02°37'37" W
L27	7.50'	N 10°41'43" E

LEGEND

- C1 CURVE NUMBER
- FCIR FOUND CAPPED IRON ROD
- LB LICENSED BUSINESS
- SCIR SET CAPPED IRON ROD 1/2" "PRM LB 2168"
- PB PLAT BOOK
- PG PAGE
- PLS PROFESSIONAL LAND SURVEYOR
- PRM PERMANENT REFERENCE MONUMENT
- SCM SET 4"x4" CONCRETE MONUMENT "PRM LB 2168"
- ORB OFFICIAL RECORDS BOOK

CURVE	RADIUS	LENGTH	DELTA	CHORD	BEARING
C1	470.00'	7.83'	00°57'15"	7.83'	N 02°58'37" W
C2	496.98'	127.16'	14°39'36"	126.81'	N 86°38'05" W
C3	145.00'	194.37'	76°48'17"	180.14'	N 40°54'08" W
C4	470.00'	296.63'	36°09'39"	291.73'	N 20°34'50" W
C5	556.98'	142.51'	14°39'40"	142.12'	N 86°38'05" W
C6	486.98'	29.06'	03°25'09"	29.06'	N 89°27'34" W
C7	486.98'	10.20'	01°12'00"	10.20'	S 89°56'01" W
C8	486.98'	9.20'	01°04'58"	9.20'	N 79°50'46" W
C9	480.00'	7.37'	00°52'48"	7.37'	N 02°56'23" W
C10	496.98'	20.01'	02°18'23"	20.00'	S 87°11'18" W

CUMBEY & FAIR, INC.
L.B. #2168
2463 ENTERPRISE ROAD
CLEARWATER, FLORIDA 33763
(727) 797-8982
J.N. 2002.07 SHEET 2 OF 2