

Prepared by and return to:
Administrative Services Dept.
Attn: Josh Rosado
509 East Avenue South
Clearwater, FL 33756

Property Appraiser
PW Operations

COUNTY DEED

THIS DEED, made this _____ day of _____, 2022 by PINELLAS COUNTY, a political subdivision of the State of Florida, whose address is 509 East Avenue South, Clearwater, Florida 33756, hereinafter referred to as "Grantor", to PHILIP BELEJCHAK AND NADINE BELEJCHAK, whose mailing address is 998 Osprey Court, Palm Harbor, Florida 34683, hereinafter referred to as "Grantee".

WITNESSETH

That the said Grantor, for and in consideration of the sum of One Dollar (\$1.00) to it in hand paid by the Grantee, receipt whereof is hereby acknowledged, has granted, bargained, and sold to the Grantee, his or her heirs and assigns forever, the following described land lying and being in Pinellas County, Florida:

Lands described in Exhibit "A" attached hereto and made a part hereof.

IN WITNESS WHEREOF, the said Grantor has caused these presents to be executed in its name by its Board of County Commissioners, acting by the Chairman of said Board, the day and year first written above.

[Signature page to follow]

SIGNED AND DELIVERED

IN THE PRESENCE OF:

ATTEST: KEN BURKE
Clerk of the Circuit Court

PINELLAS COUNTY, FLORIDA
by and through its Board of County
Commissioners

By: _____
Deputy Clerk

By: _____
Charlie Justice, Chairman

(Official Seal)

FLORIDA DESIGN CONSULTANTS
 20525 AMBERFIELD DRIVE, SUITE 201
 LAND O' LAKES, FLORIDA 34638
 SURVEY AND MAPPING SECTION
 PHONE: (800) 532-1047
 WWW.FLDESIGN.COM



**FLORIDA DESIGN
 CONSULTANTS, INC.**
 — THINK IT. ACHIEVE IT. —

**SECTION 2, TOWNSHIP 28 SOUTH, RANGE 15 EAST
 DESCRIPTION**

LEGAL DESCRIPTION:

A parcel of land being a portion of Section 2, Township 28 South, Range 15 East, Pinellas County, Florida, being more particularly described as follows:

COMMENCE at the Southeast corner of Lot 5, according to the plat of OSPREY POINT, as recorded in Plat Book 98, Page 10, of the Public Records of Pinellas County, Florida; thence N33°31'22"E, along the East line of said Lot 5, according to the Plat of OSPREY POINT (being the basis of bearings for this legal description), for 27.49 feet to the POINT OF BEGINNING; thence leaving said East line of Lot 5, N65°05'27"W, for 9.87 feet to the point of intersection with the Wetland Jurisdictional Delineation line established by Birkitt Environmental Services, Inc. on 3-11-2021; thence N17°32'55"E, along said Wetland Jurisdictional Delineation line, for 6.05 feet; thence leaving said Wetland Jurisdictional Delineation line, S65°05'27"E, for 16.02 feet; thence S35°58'05"E, for 14.58 feet to the point of intersection with the mean High Water Line Elevation 0.82 feet, North American Vertical Datum, 1988 adjustment (NAVD88), according to the Florida Department of Environmental Protection, File Number 8019; thence S35°07'05"W, along said Mean High Water line for 6.19 feet; thence leaving said Mean High Water line, N46°51'17"W, for 0.76 feet; thence, N35°58'05"W, for 14.28 feet; thence N65°05'27"W, for 3.82 feet to the POINT OF BEGINNING;

Containing 178 square feet or 0.004 acres, more or less.

Revision 1: Addressing County Comments 10-7-2021
 Revision 2: Addressing County Comments 10-8-2021

Additions or deletions by other than the Professional Surveyor and Mapper in responsible charge are prohibited. Sketch and/or Description is invalid without the original signature and seal of the Professional Surveyor and Mapper.

CALCULATED BY: RCW3	The above Sketch and Land description was prepared under my supervision and is true and correct to the best of my knowledge and belief. By: <u>[Signature]</u> DATE <u>10-8-2021</u> JARED T. PATENAUDE, PROFESSIONAL SURVEYOR AND MAPPER LICENSE NUMBER: 6971 STATE OF FLORIDA, PHONE # (800) 532-1047
CHECKED BY: JTP	
S.F.N.: F1332_00541	

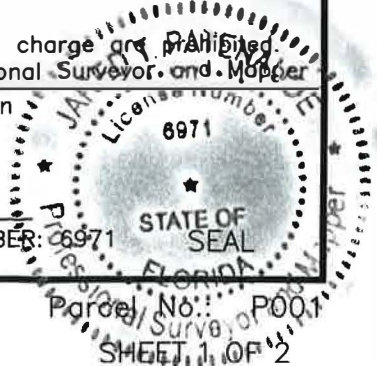

EXHIBIT A

FLORIDA DESIGN CONSULTANTS
 20525 AMBERFIELD DRIVE, SUITE 201
 LAND O' LAKES, FLORIDA 34638
 SURVEY AND MAPPING SECTION
 PHONE: (800) 532-1047
 WWW.FLDESIGN.COM



FLORIDA DESIGN CONSULTANTS, INC.
 THINK IT. ACHIEVE IT.

SECTION 2, TOWNSHIP 28 SOUTH, RANGE 15 EAST
SKETCH - NOT A SURVEY

LEGEND	
COR	CORNER
EL	ELEVATION
FDEP	FLORIDA DEPARTMENT OF ENVIRONMENTAL PROTECTION
MHW	MEAN HIGH WATER
NAVD88	NORTH AMERICAN VERTICAL DATUM 1988 ADJUSTMENT
NO.	NUMBER
PB	PLAT BOOK
POB	POINT OF BEGINNING
POC	POINT OF COMMENCEMENT
PG	PAGE

LINE TABLE		
LINE #	BEARING	LENGTH
L1	N65°05'27"W	9.87'
L2	N17°32'55"E	6.05'
L3	S65°05'27"E	16.02'
L4	S35°58'05"E	14.58'
L5	S35°07'05"W	6.19'
L6	N46°51'17"W	0.76'
L7	N35°58'05"W	14.28'
L8	N65°05'27"W	3.82'

WETLAND JURISDICTIONAL DELINEATION LINE ESTABLISHED BY BIRKITT ENVIRONMENTAL SERVICES, INC. ON 3-11-2021

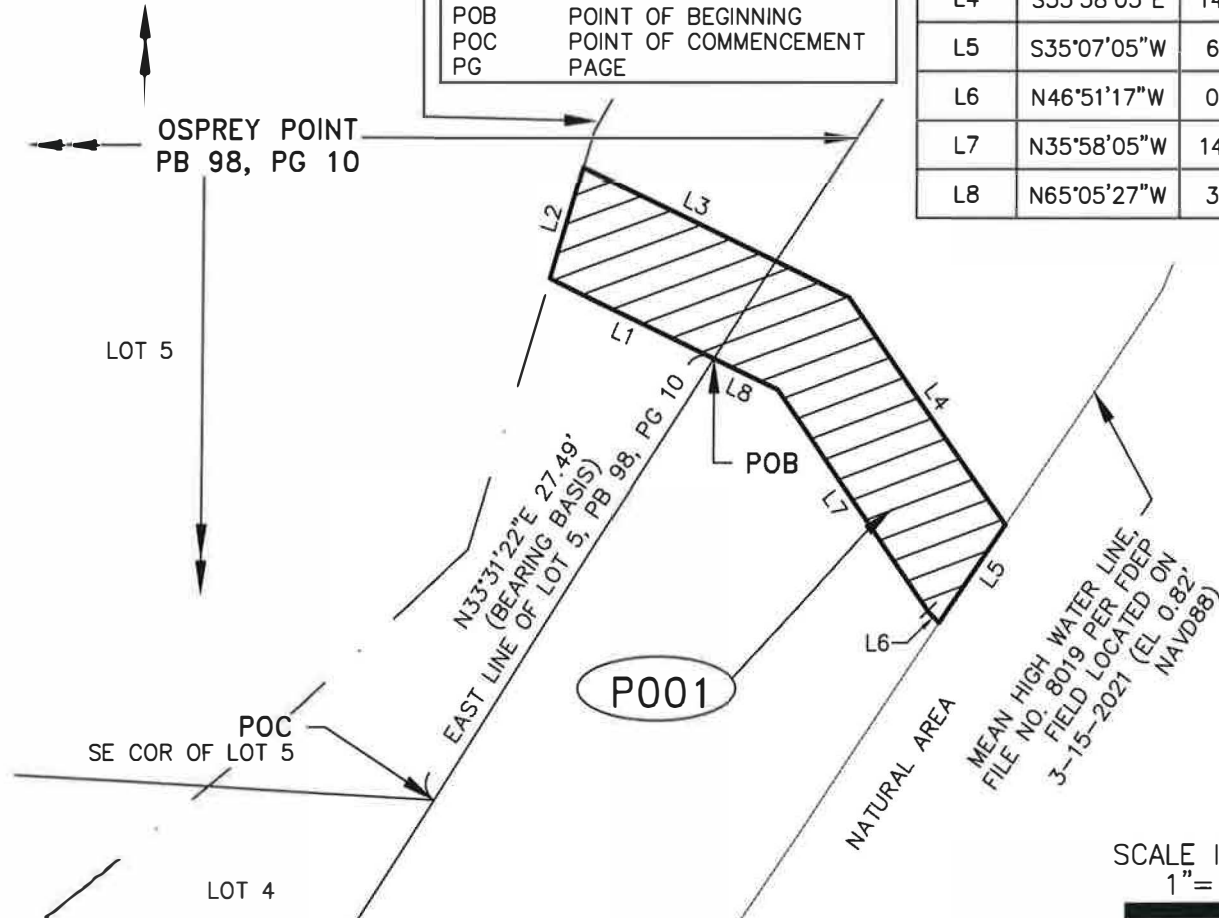

Revision 1: Addressing County Comments 10-7-2021
 Revision 2: Addressing County Comments 10-8-2021

SCALE IN FEET
 1" = 10'

Additions or deletions by other than the Professional Surveyor and Mapper in responsible charge are prohibited. Sketch and/or Description is invalid without the original signature and seal of the Professional Surveyor and Mapper.

CALCULATED BY: RCW3	The above Sketch and Land description was prepared under my supervision and is true and correct to the best of my knowledge and belief. By: <i>[Signature]</i> JARED T. PATENAUDE, PROFESSIONAL SURVEYOR AND MAPPER LICENSE NUMBER: 6971 STATE OF FLORIDA, PHONE # (800) 532-1047
CHECKED BY: JTP	
S.F.N.:	
F1332_0054	

