

AGREEMENT FOR "PIGGYBACK" PURCHASE

Contract Ref. #26-0245-PB Utilities Pump Tanker Truck

This Agreement ("Agreement") is entered into on the date last executed below ("Effective Date"), by and between Pinellas County, a subdivision of the State of Florida whose primary address is 315 Court Street, Clearwater, Florida 33756 ("County") and Sun State International Trucks, LLC. whose primary address is 6020 Adamo Drive Tampa, FL 33619 ("Contractor") (jointly, the "Parties").

WHEREAS, the County is authorized to procure goods and services based on the contract terms and pricing received by other governmental competitive solicitation processes which are made available to local public procurement units; and

WHEREAS, following a competitive procurement process, Florida Sheriffs Association entered into an Agreement FSA25-VEH23.0 for Heavy Trucks and Buses, effective October 1, 2025 (the "FSA25-VEH23.0 Agreement"); and

WHEREAS, the County has elected to utilize resulting contract terms and pricing of the cooperative procurement or solicitation as reflected in the FSA25-VEH23.0 Agreement; and

WHEREAS, Contractor represents that it has the experience and expertise to provide the Goods and Services as set forth in this Agreement.

NOW THEREFORE, the Parties agree as follows:

A. Documents Comprising Agreement.

This Agreement, including the Exhibits listed below, constitutes the entire agreement and understanding of the Parties with respect to the transactions and services contemplated hereby and supersedes all prior agreements, arrangements, and understandings relating to the subject matter of the Agreement. The documents listed below are hereby incorporated into and made a part of this Agreement:

1. Exhibit A "Pinellas County Terms and Conditions"
2. Exhibit B "Insurance Requirements"
3. Exhibit C "Proposal 12530-01"
4. Exhibit D "Customization Options for Chassis"
5. Exhibit E "5000-Gallon Imperial Tank"
6. Exhibit F "Impact of Section 232 Federal Tariff - effective 11-1-1-25"
7. Exhibit G "Agreement FSA25-VEH23.0 for Heavy Trucks and Buses"

In the case of conflict, the terms of this document govern, followed by the terms of the attached Exhibits, which control in the order listed above,

- B. Term.** The initial term of this Agreement is effective from the Effective Date through September 30, 2027 (the "Contract Term"). The Parties may extend this agreement in conjunction with any

extensions made to the FSA25-VEH23.0 Agreement by a mutually agreed upon written amendment to this Agreement. If the Parties desire to extend past the expiration date of the FSA25-VEH23.0 Agreement, the Parties may do so by entering into a mutually agreed upon written amendment to this Agreement. The Agreement will not automatically renew.

- C. **Expenditures Cap.** Payment and pricing terms for the initial and renewal terms are subject to the cost or fee schedule in Exhibit C. Notwithstanding the above, County expenditures under the Agreement will not exceed \$311,407.00 for the Contract Term without a written amendment to this Agreement.

D. **Modifications to the FSA25-VEH23.0 Agreement**

1. **The County as the Contracting Party.** All references within the FSA25-VEH23.0 Agreement to the “Florida Sheriffs Association,” will be interpreted as pertaining to the County. It is understood that wherever the words “Florida Sheriffs Association”, “FSA”, or other references to the Florida Sheriffs Association that appear in the FSA25-VEH23.0 Agreement shall be read as “Pinellas County.” Any term in the FSA25-VEH23.0 Agreement that is applicable in law or fact solely to the Florida Sheriffs Association that cannot be reasonably applied to the County is severed from the Agreement, with no effect on the remaining terms.
2. **Insurance.** The Contractor must provide a certificate of insurance and endorsement in accordance with the insurance requirements listed in Exhibit B. The Contractor shall obtain and maintain and require any subcontractor(s) to obtain and maintain, at all times during its performance of the Agreement in the amounts set forth in the noted exhibit. For Agreements with a Completed Operations exposure, Vendor shall maintain coverage and provide evidence of insurance for 2 years beyond final acceptance. All insurance policies shall be from responsible companies duly authorized to do business in the State of Florida and have an AM Best rating of VIII or better.
3. **Paragraph 1.03 (Term of Contract)** is revised to clarify that, as between the County and Contractor, the “Effective Date” is the date listed above. Should the FSA25-VEH23.0 Agreement terminate before the end of the term of the Agreement between the County and Contractor, all applicable terms of the conditions of the FSA25-VEH23.0 Agreement incorporated herein will remain in full force and effect.
4. For notices required to be sent between County and Contractor, the following County contact is to be used, unless updated in writing by the County: information:

Pinellas County

Attn: N. Thomas Bayot

400 S Fort Harrison Ave

(727) 464-4106

nbayot@pinellas.gov

E. Entirety. This Agreement constitutes the entire agreement between the Parties.

IN WITNESS WHEREOF, the Parties have caused this Agreement to be executed by their undersigned officials, who are duly authorized to bind the Parties to the Agreement.

For CONTRACTOR:

Signature



Print Name & Title **David Metcalf, Truck Specification Specialist**

Date **3/20/2026**

For COUNTY:

Signature

Print Name & Title

Date

APPROVED AS TO FORM

By: Keiah Townsend
Office of the County Attorney

Exhibit A – Pinellas County Standard Terms and Conditions

Pinellas County Standard Terms & Conditions, located on Pinellas County Purchasing's website, effective 4/10/2025, posted at <https://pinellas.gov/county-standard-terms-conditions/> is incorporated into and made part of this Agreement.

Exhibit B – Insurance Requirements

1. INSURANCE

The Contractor must provide a certificate of insurance and endorsement in accordance with the insurance requirements listed below, prior to recommendation for award.

The Contractor shall obtain and maintain, and require any sub-contractors to obtain and maintain, at all times during its performance of the Agreement, insurance of the types and in the amounts set forth. For projects with a Completed Operations exposure, Contractor shall maintain coverage and provide evidence of insurance for two (2) years beyond final acceptance. All insurance policies shall be from responsible companies duly authorized to do business in the State of Florida and have an AM Best rating of A- VIII or better.

- A. Submittals should include the Contractor's current Certificate(s) of Insurance. If Contractor does not currently meet insurance requirements, Contractor shall also include verification from their broker or agent that any required insurance not provided at that time of submittal will be in place prior to the award of contract.

Upon selection of Contractor for award, the selected Contractor shall email certificate that is compliant with the insurance requirements. If the certificate received is compliant, no further action may be necessary. The Certificate(s) of Insurance shall be signed by authorized representatives of the insurance companies shown on the Certificate(s). The Certificate holder section shall indicate Pinellas County, a Political Subdivision of the State of Florida, 400 S Fort Harrison Ave, Clearwater, FL 33756. Pinellas County, a Political Subdivision shall be named as an Additional Insured for General Liability. A Waiver of Subrogation for Workers Compensation shall be provided if Workers Compensation coverage is a requirement.

- B. Approval by the County of any Certificate(s) of Insurance does not constitute verification by the County that the insurance requirements have been satisfied or that the insurance policy shown on the Certificate(s) of Insurance is in compliance with the requirements of the Agreement. The County reserves the right to require a certified copy of the entire insurance policy, including endorsement(s), at any time during the Bid and/or contract period.
- C. If any insurance provided pursuant to the Agreement expires or cancels prior to the completion of the work you will be notified by COI360, the authorized Contractor of Pinellas County. Upon notification, renewal certificate(s) of Insurance and endorsement(s) should be furnished to Pinellas County Risk Management at InsuranceCerts@pinellas.gov and to COI360 c/o MDi Data at PinellasSupport@MDiclaims.io by the Contractor or their agent prior to the expiration date.
- 1) The Contractor shall also notify the County within seventy-two (72) hours after receipt, of any notices of expiration, cancellation, nonrenewal or adverse material change in coverage received by said Contractor from its insurer. Notice shall be given by email to Pinellas County Risk Management at InsuranceCerts@pinellas.gov. Nothing contained herein shall absolve Contractor of this requirement to provide notice. Regardless of notification, it remains the Contractor's obligation to, at all times, maintain the requisite insurance.
 - 2) Should the Contractor, at any time, not maintain the insurance coverages required herein, the County may terminate the Agreement.
- D. If subcontracting is allowed under this Bid, the Primary Contractor shall obtain and maintain, at all times during its performance of the Agreement, insurance of the types and in the amounts set forth; and require any subcontractors to obtain and maintain, at all times during its performance of the Agreement, insurance limits as it may apply to the portion of the Work performed by the subcontractor; but in no event will the insurance limits be less than \$500,000 for Workers' Compensation/Employers' Liability, and \$1,000,000 for General Liability and Auto Liability if required below.

All subcontracts between the Contractor and its subcontractors shall be in writing and are subject to the County's prior written approval. Further, all subcontracts shall;

- 1) require each subcontractor to be bound to the Contractor to the same extent the Contractor is bound to the County by the terms of the Contract Documents, as those terms may apply to the portion of the Work to be performed by the subcontractor;
- 2) provide for the assignment of the subcontracts from the Contractor to the County at the election of Owner upon termination of the Contract;
- 3) provide that County will be an additional indemnified party of the subcontractor.

- 4) provide that the County will be an additional insured on all insurance policies required to be provided by the subcontractor except workers compensation and professional liability;
- 5) provide a waiver of subrogation in favor of the County and other insurance terms and/or conditions as outlined below;
- 6) assign all warranties directly to the County;
- 7) identify the County as an intended third-party beneficiary of the subcontract. The Contractor shall make available to each proposed subcontractor, prior to the execution of the subcontract, copies of the Contract Documents to which the subcontractor will be bound by this Section C and identify to the subcontractor any terms and conditions of the proposed subcontract which may be at variance with the Contract Documents.

E. Each insurance policy and/or certificate shall include the following terms and/or conditions:

- 1) The Named Insured on the Certificate of Insurance and insurance policy must match the entity's name that responded to the solicitation and/or is signing the agreement with the County.
- 2) Companies issuing the insurance policy, or policies, shall have no recourse against County for payment of premiums or assessments for any deductibles which all are at the sole responsibility and risk of Contractor.
- 3) The term "County" or "Pinellas County" shall include all Authorities, Boards, Bureaus, Commissions, Divisions, Departments and Constitutional offices of County and individual members, employees thereof in their official capacities, and/or while acting on behalf of Pinellas County.
- 4) All policies shall be written on a primary, non-contributory basis.

The minimum insurance requirements and limits for this Agreement, which shall remain in effect throughout its duration and for two (2) years beyond final acceptance for projects with a Completed Operations exposure, are as follows:

- 1) **Workers' Compensation Insurance** Worker's Compensation Insurance is required if required pursuant to Florida law. If, pursuant to Florida law, Worker's Compensation Insurance is required, employer's liability, also known as Worker's Compensation Part B, is also required in the amounts set forth herein.

Limits

Employers' Liability Limits	Florida Statutory
Per Employee	\$ 500,000
Per Employee Disease	\$ 500,000
Policy Limit Disease	\$ 500,000

If Vendor/Contractor is not required by Florida law, to carry Workers Compensation Insurance in order to perform the requirements of this Agreement, County Waiver Form for workers compensation must be executed, submitted, and accepted by Risk Management. Failure to obtain required Worker's Compensation Insurance without submitting and receiving a waiver from Risk Management constitutes a material breach of this Agreement.

- 2) **Commercial General Liability Insurance** including, but not limited to, Independent Vendor, Contractual Liability Premises/Operations, Products/Completed Operations, and Personal Injury.

Limits

Combined Single Limit Per Occurrence	\$ 1,000,000
Products/Completed Operations Aggregate	\$ 2,000,000
Personal Injury and Advertising Injury	\$ 1,000,000
General Aggregate	\$ 2,000,000

- 3) **Business Automobile or Trucker's/Garage Liability Insurance** covering owned, hired, and non- owned vehicles. If the Consultant does not own any vehicles, then evidence of Hired and Non-owned coverage is sufficient. Coverage shall be on an "occurrence" basis, such insurance to include coverage for loading and unloading hazards, unless Consultant can show that this coverage exists under the Commercial General Liability policy.

Limit

Combined Single Limit Per Accident	\$1,000,000
------------------------------------	-------------

4) **Excess or Umbrella Liability Insurance** excess of the primary coverage required, in paragraphs (1), (2), and (3) above.

Limits

Each Occurrence	\$ 1,000,000
General Aggregate	\$ 1,000,000

5) **Property Insurance** Vendor will be responsible for all damage to its own property, equipment and/or materials.



Hx620 SBA

Sales Proposal For:

PINELLAS COUNTY

Presented By:

SUN STATE INTL TRKS, LLC

Prepared For:
 PINELLAS COUNTY
 Greg Herremans
 9685 Ulmerton Rd.
 Largo, FL 33771-3699
 (727)582 - 3007
 Reference ID: 5,000 Vac Truck

Presented By:
 SUN STATE INTL TRKS, LLC
 Christopher Harris
 6020 ADAMO DRIVE
 TAMPA FL 33619 -
 (813)621-1331

Thank you for the opportunity to provide you with the following quotation on a new International truck. I am sure the following detailed specification will meet your operational requirements, and I look forward to serving your business needs.

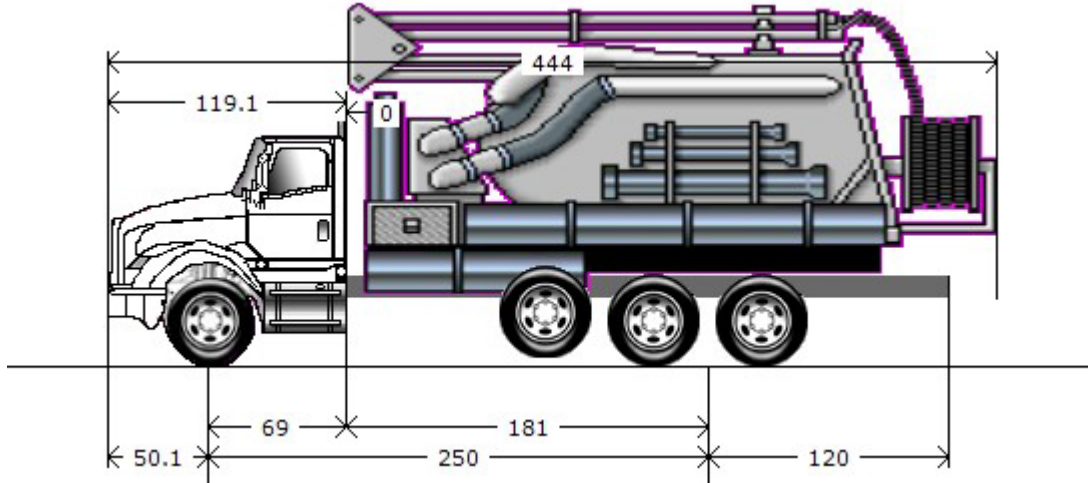

Model Profile
2026 HX620 SBA (HX620)

AXLE CONFIG: 6X4
APPLICATION: Septic Pumper
MISSION: Requested GVWR: 64000. Calc. GVWR: 79500. Calc. GCWR: 140000
 Calc. Start / Grade Ability: 33.15% / 2.93% @ 55 MPH
 Calc. Geared Speed: 80.6 MPH

DIMENSION: Wheelbase: 250.00, CA: 181.00, Axle to Frame: 120.00

ENGINE, DIESEL: {Cummins X15 525} Performance Series, EPA 2024, 525HP @ 1900 RPM, 1850 lb-ft Torque @ 1000 RPM, 1900 RPM Governed Speed, 538 Peak HP (Max)

TRANSMISSION, AUTOMATIC: {Allison 4500 RDS} 6th Generation Controls, Wide Ratio, 6-Speed with Double Overdrive, with PTO Provision, Less Retarder, Includes Oil Level Sensor, On/Off Highway

CLUTCH: Omit Item (Clutch & Control)

AXLE, FRONT NON-DRIVING: {Meritor MFS-20-133A} Wide Track, I-Beam Type, 20,000-lb Capacity

AXLE, REAR, TANDEM: {Meritor RT-46-164P} Single Reduction, Standard Width, 46,000-lb Capacity, with Lube Oil Pump, Driver Controlled Locking Differential in Forward-Rear and Rear-Rear Axle, 200 Wheel Ends Gear Ratio: 4.30

CAB: Conventional, Day Cab

TIRE, FRONT: (2) 425/65R22.5 Load Range L HAC 3 (CONTINENTAL), 465 rev/mile, 68 MPH, All-Position

TIRE, REAR: (8) 11R22.5 Load Range G HDR2+ (CONTINENTAL), 491 rev/mile, 75 MPH, Drive

SUSPENSION, REAR, AIR, TANDEM: {Hendrickson HAS-460-55} 46,000-lb Capacity, 55" Axle Spacing, 9.5" Ride Height, with Shock Absorbers

PAINT: Cab schematic 100LZ
 Location 1: 9219, Winter White (Std)
 Chassis schematic N/A

<u>Code</u>	<u>Description</u>	<u>F/R Wt</u> (lbs)	<u>Tot Wt</u> (lbs)
HX62000	Base Chassis, Model HX620 SBA with 250.00 Wheelbase, 181.00 CA, and 120.00 Axle to Frame.	9318/6671	15989

AXLE CONFIGURATION

1AND	AXLE CONFIGURATION 6x4	0/0	0
	<u>Notes</u> : Pricing may change if axle configuration is changed.		

ENGINE

12EXJ	ENGINE, DIESEL {Cummins X15 525} Performance Series, EPA 2024, 525HP @ 1900 RPM, 1850 lb-ft Torque @ 1000 RPM, 1900 RPM Governed Speed, 538 Peak HP (Max)	601/32	633
12VKK	EMISSION, CALENDAR YEAR {Cummins X15} EPA, OBD and GHG Certified for Calendar Year 2026	0/0	0
12XCS	CARB EMISSION WARR COMPLIANCE Does Not Comply with CARB Emission Warranty	0/0	0
12WZE	CARB IDLE COMPLIANCE Does Not Comply with California Clean Air Idle Regulations	0/0	0
12WVG	EPA IDLE COMPLIANCE Low NOx Idle Engine, Complies with EPA Clean Air Regulations; Includes "Certified Clean Idle" Decal on Hood	0/0	0
10UAV	VEHICLE REGISTRATION IDENTITY ID for Non-CARB Omnibus and/or Non-ACT Adopting State or Exempt Vehicle. Not for use on vehicles registering in CA. Contains non-mitigated legacy engine & cannot be registered in CA unless exempt. You may be held liable under state law for failure to properly register vehicle.	0/0	0
	<u>Notes</u> : CANNOT BE REGISTERED IN CA. For vehicles that will be registered in States other than CA.		
12XBC	RADIATOR Aluminum, Welded, Down Flow, Front to Back System, 1325 SqIn, with 806 SqIn Charge Air Cooler	0/0	0
	<u>Includes</u> : RADIATOR HOSES Premium, Rubber		
12THT	FAN DRIVE {Horton Drivemaster} Two-Speed Type, Direct Drive, with Residual Torque Device for Disengaged Fan Speed	0/0	0
	<u>Includes</u> : FAN Nylon		
12VCA	AIR CLEANER Single Element, with Pre-Cleaner, Engine Mounted	0/0	0
12703	ANTI-FREEZE Red, Extended Life Coolant; To -40 Degrees F/ -40 Degrees C, Freeze Protection	0/0	0
12VGU	ENGINE CONTROL, REMOTE MOUNTED for X15 Engines	0/0	0
12WTA	FAN DRIVE SPECIAL EFFECTS Fan Cooling Ring with Fan Shroud Effects, Engine Mounted	0/0	0
12WGA	HOSE CLAMPS, RADIATOR HOSES , Mechanical Type; with Constant-Tension Functionality	0/0	0

<u>Code</u>	<u>Description</u>	<u>F/R Wt</u> (lbs)	<u>Tot Wt</u> (lbs)
12WYZ	RADIATOR DRAIN & FILL FITTING SPECIAL; To Vacuum Out or Fill the Cooling System from the Bottom of Radiator, for Use with Quick-Connect Radiator Drain Tool or Shop Coolant Evacuation-Fill System	0/0	0

TRANSMISSION

13BEK	TRANSMISSION, AUTOMATIC {Allison 4500 RDS} 6th Generation Controls, Wide Ratio, 6-Speed with Double Overdrive, with PTO Provision, Less Retarder, Includes Oil Level Sensor, On/Off Highway	306/65	371
13WUH	ALLISON SPARE INPUT/OUTPUT for Rugged Duty Series (RDS), Airport Refueler, Sewer Evac, Package Number 150	0/0	0
13WVV	NEUTRAL AT STOP Allison Transmission Shifts to Neutral When Service Brake is Depressed and Vehicle is at Stop; Remains in Neutral Until Service Brake is Released	0/0	0
13WHL	OIL COOLER, TRANSMISSION Remote Mounted, for Automatic Transmission	95/-11	84
13WYU	SHIFT CONTROL PARAMETERS {Allison} 3000 or 4000 Series Transmissions, Performance Programming	0/0	0
13WLM	TRANSMISSION OIL Synthetic; 63 thru 76 Pints	0/0	0
13WET	TRANSMISSION SHIFT CONTROL Column Mounted Stalk Shifter, Not for Use with Allison 1000 & 2000 Series Transmission	1/0	1

CLUTCH

11001	CLUTCH Omit Item (Clutch & Control)	-118/-16	-134
-------	-------------------------------------	----------	------

REAR AXLES, SUSPENSIONS

14HRE	AXLE, REAR, TANDEM {Meritor RT-46-164P} Single Reduction, Standard Width, 46,000-lb Capacity, with Lube Oil Pump, Driver Controlled Locking Differential in Forward-Rear and Rear-Rear Axle, 200 Wheel Ends . Gear Ratio: 4.30	0/514	514
14ULB	SUSPENSION, REAR, AIR, TANDEM {Hendrickson HAS-460-55} 46,000-lb Capacity, 55" Axle Spacing, 9.5" Ride Height, with Shock Absorbers	0/-12	-12
14WNH	AXLE, PUSHER, LIFT TYPE {Watson & Chalin SL1190SSR Tru-Trk Alumilite} 13,500-lb Capacity, One Self-Steer Axle	265/554	819
14UAC	AXLE SPACING, FIRST PUSHER 54" Ahead of Drive Axle	0/0	0
14RAR	AXLE, LIFT, CONTROLS for One Lift Axle; Controls Inside and Outside Cab; Includes Lift/Lower Switch Inside Cab on Dash; Pressure Gauge and Pressure Regulator Outside Cab	0/0	0
14WBA	LIFT AXLE ENGR REVIEW Special Quotation to Allow Engineering Review of Lift Axle Configurations	0/0	0
14WBN	DIFF. SWITCH CONTROLS Two Independent Switches for Control Traction Differentials on Tandem Rear Axles, Mounted on Dash	1/0	1
14899	SUSPENSION AIR CONTROL VALVE Pressure Release Control In Cab	0/1	1

FRONT AXLES

2ARY	AXLE, FRONT NON-DRIVING {Meritor MFS-20-133A} Wide Track, I-Beam Type, 20,000-lb Capacity	126/0	126
------	---	-------	-----

<u>Code</u>	<u>Description</u>	<u>F/R Wt</u> (lbs)	<u>Tot Wt</u> (lbs)
FRONT SUSPENSIONS			
3AGA	SUSPENSION, FRONT, SPRING Parabolic Taper Leaf, Shackle Type, 20,000-lb Capacity, with Shock Absorbers	-26/0	-26
CABS, COWLS, BODIES			
16030	CAB Conventional, Day Cab <u>Includes</u> : CAB REAR SUSPENSION Air : CLEARANCE/MARKER LIGHTS (5) LED Roof Mounted : COAT HOOK, CAB Located on Rear Wall, Centered Above Rear Window : CONSOLE, CENTER Includes Two Cup Holders and One Additional Storage Area : CONSOLE, OVERHEAD Molded Plastic with Dual Storage Pockets, Retainer Nets and CB Radio Pocket; Located Above Driver and Passenger : COURTESY LIGHT (2) Driver and Passenger Door Mounted : DOME LIGHT, CAB Rectangular, Door and Instrument Panel Mounted Switch Activated, Timed Theater Dimming, Center Mounted, Integral to Console : FLOOR COVERING Rubber, Black : GLASS, ALL WINDOWS Tinted : GRAB HANDLE, CAB INTERIOR (1) "A" Pillar Mounted, Passenger Side : GRAB HANDLE, CAB INTERIOR (4) "B" Pillar and Door Mounted, Two Each Side : READING LIGHT, CAB Located in Overhead Console : STORAGE POCKET, DOOR (2) Full Length, Driver and Passenger Door	0/0	0
16XTM	ACCESS, CAB Aluminum, Driver & Passenger Sides, Two Steps per Door, for use with Day Cab or Sleeper Cab	0/0	0
16BAM	AIR CONDITIONER with Integral Heater and Defroster <u>Includes</u> : HOSE CLAMPS, HEATER HOSE Mubea Constant Tension Clamps	0/0	0
16ATC	AUTOMATIC CLIMATE CONTROL Automatically Maintains Cabin Comfort Based on Selected Temperature	0/0	0
16VKK	CAB INTERIOR TRIM Diamond, for Day Cab	0/0	0
16GEG	GAUGE CLUSTER Premium Level; English with English Electronic Speedometer <u>Includes</u> : GAUGE CLUSTER DISPLAY: Base Level (3" Monochromatic Display), Premium Level (5" LCD Color Display); Odometer, Voltmeter, Diagnostic Messages, Gear Indicator, Trip Odometer, Total Engine Hours, Trip Hours, MPG, Distance to Empty/ Refill for : GAUGE CLUSTER Speedometer, Tachometer, Engine Coolant Temp, Fuel Gauge, DEF Gauge, Oil Pressure Gauge, Primary and Secondary Air Pressure : WARNING SYSTEM Low Fuel, Low DEF, Low Oil Pressure, High Engine Coolant Temp, Low Battery Voltage (Visual and Audible), Low Air Pressure (Primary and Secondary)	0/0	0
16SDC	GRAB HANDLE, EXTERIOR (2) Chrome, Towel Bar Type, with Anti-Slip Rubber Inserts, for Cab Entry Mounted Left and Right Side at B-Pillar	6/0	6
16XJP	INSTRUMENT PANEL Wing Panel	0/0	0
16HKT	IP CLUSTER DISPLAY On Board Diagnostics Display of Fault Codes in Gauge Cluster	0/0	0
16SNS	MIRRORS (2) Aero Pedestal, Power Adjust, Heated, Black Heads and Arms, 6.5" x 14" Flat Glass, Includes 6.5" x 6" Convex Mirrors, for 102" Load Width	0/0	0

<u>Code</u>	<u>Description</u>	<u>F/R Wt</u> (lbs)	<u>Tot Wt</u> (lbs)
	<u>Notes</u> : Mirror Dimensions are Rounded to the Nearest 0.5"		
16XBZ	MODESTY PANEL Painted Body Color, with Amber Lens LED Lights, for Day Cab	0/0	0
16VLV	MONITOR, TIRE PRESSURE Omit	-10/-1	-11
16VCC	SEAT BELT All Orange; 1 to 3	0/0	0
16LWX	SEAT, DRIVER {ISRI} Series 400, Air Suspension, High Back, Vinyl, Passive Bolsters, Double Chamber Lumbar, Heat, Inboard Armrest, Suspension Cover, Fore/Aft Isolator, Cushion Extension, Cushion Tilt, Seat Tilt, Memory Quickdown	0/0	0
16SRZ	SEAT, PASSENGER {ISRI} Series 400, Air Suspension, High Back, Vinyl, Passive Bolsters, Double Chamber Lumbar, Heat, Inboard Armrest, Suspension Cover, Fore/Aft Isolator, Cushion Extension, Cushion Tilt, Seat Tilt, Memory Quickdown	69/18	87
16UZJ	STORAGE, REAR WALL Storage Pocket, Located on Back Wall Between Driver and Passenger Seats	3/0	3
16XWV	SUNSHADE, EXTERIOR Aerodynamic, Painted Roof Color, with Integral LED Clearance/Marker Lights	16/1	17
16WJU	WINDOW, POWER (2) and Power Door Locks, Left and Right Doors, Includes Express Down Feature	0/0	0

FRAMES

1CGC	FRAME RAILS Heat Treated Alloy Steel (120,000 PSI Yield); 12.250" x 3.380" x 0.375" (304.8mm x 85.6mm x 9.5mm); 550.0" (13970mm) Maximum OAL	106/565	671
1LRB	BUMPER, FRONT Contoured, Steel, Painted, Heavy Duty, for HX	0/0	0
1AMR	CROSSMEMBER, FRAME TIE for Standard Duty	40/2	42
1652	CROSSMEMBER, REAR Relocated to End of Frame	5/60	65
1SAP	CROSSMEMBER, REAR, AF (1) 5-Piece	-16/81	65
1LEH	LICENSE PLATE HOLDER Single Plate, Swing Type, Mounted Below Front Bumper	1/0	1
1WXM	WHEELBASE RANGE 238" (605cm) Through and Including 295" (750cm)	250/-250	0

BRAKES

4091	BRAKE SYSTEM, AIR Dual System for Straight Truck Applications <u>Includes</u> : BRAKE LINES Color and Size Coded Nylon : PARKING BRAKE CONTROL Yellow Knob, Located on Instrument Panel : PARKING BRAKE VALVE For Truck : QUICK RELEASE VALVE On Rear Axle for Spring Brake Release: 1 for 4x2, 2 for 6x4 : SPRING BRAKE MODULATOR VALVE SR-7 with relay valve for 6x4/8x6	0/0	0
4AZA	AIR BRAKE ABS {Bendix AntiLock Brake System} 4-Channel (4 Sensor/4 Modulator) Full Vehicle Wheel Control System	0/0	0
4GBM	BRAKE, PARKING Manual Push-Pull Pneumatic Parking Brake	1/0	1
4XDT	BRAKES, FRONT {Meritor 16.5X6 Q-PLUS CAST} Air S-Cam Type, Cast Spider, Fabricated Shoe, Double Anchor Pin, Size 16.5" X 6", 23,000-lb Capacity	33/0	33

<u>Code</u>	<u>Description</u>	<u>F/R Wt</u> (lbs)	<u>Tot Wt</u> (lbs)
4EXV	BRAKE CHAMBERS, FRONT AXLE {Bendix} 24 SqIn	4/0	4
4LAA	SLACK ADJUSTERS, FRONT {Haldex} Automatic	14/0	14
4XDR	BRAKES, REAR {Meritor 16.5X7 Q-PLUS CAST} Air S-Cam Type, Cast Spider, Fabricated Shoe, Double Anchor Pin, Size 16.5" X 7", 23,000-lb Capacity per Axle	0/104	104
4EXU	BRAKE CHAMBERS, REAR AXLE {Bendix EverSure} 30/30 SqIn Spring Brake	0/14	14
4LGA	SLACK ADJUSTERS, REAR {Haldex} Automatic	0/32	32
4XEE	PARK BRAKE CHAMBERS, ADDITIONAL (2) Spring Brake Type	0/60	60
4JBR	BRAKES, PUSHER AXLE Air S-Cam Type, 15" x 4.0", Includes MGM 20 Sq.In. Brake Chambers, Furnished with One Pusher Lift Axle	0/0	0
4JNJ	SLACK ADJUSTER, PUSHER AXLE {Haldex} Automatic; for Single Pusher Axle	0/0	0
4SPA	AIR COMPRESSOR {Cummins} 18.7 CFM	0/0	0
4EDM	AIR DRYER {Bendix AD-HF} with Heater, Includes Pressure Protection Circuits, Safety Valve, Integral Purge Tank, Governor Pressure Settings 110 psi Cut-In/130 psi Cut-Out, Integrated PuraGuard Coalescing Filtration	0/0	0
4VKC	AIR DRYER LOCATION Mounted Inside Left Rail, Back of Cab	0/0	0
4VKK	AIR TANK LOCATION (2) Mounted Under Battery Box, Outside Right Rail, Back of Cab, Perpendicular to Rail	0/0	0
4WXR	DRAIN VALVE (2) {Berg} with Pull Chains, for Air Tanks	0/0	0

STEERING

5PTB	STEERING GEAR (2) {Sheppard M100/M80} Dual Power	106/-10	96
5710	STEERING COLUMN Tilting and Telescoping	0/0	0
5CAW	STEERING WHEEL 4-Spoke; 18" Dia., Black	0/0	0

DRIVELINES

6DGU	DRIVELINE SYSTEM {Dana Spicer} SPL250 Main Driveline with SPL170 Interaxle Shaft, for 6x4	2/5	7
------	---	-----	---

EXHAUST SYSTEMS

7BLY	EXHAUST SYSTEM Horizontal Aftertreatment System, Frame Mounted Right Side Under Cab, for Single Vertical Tail Pipe, Cab Mounted Right Side	0/0	0
7BEU	AFTERTREATMENT COVER Aluminum	0/0	0
7SAP	ENGINE COMPRESSION BRAKE {Cummins} Interbrake For Cummins Signature/ ISX/X15 Engines; Furnished with Engine	0/0	0
7WDM	EXHAUST HEIGHT 10'	0/0	0
7WBS	MUFFLER/TAIL PIPE GUARD (1) Bright Stainless Steel	22/9	31
7WZX	SWITCH, FOR EXHAUST 3 Position, Momentary, Lighted Momentary, ON/ CANCEL, Center Stable, INHIBIT REGEN, Mounted in IP Inhibits Diesel Particulate Filter Regeneration When Switch is Moved to ON While Engine is Running, Resets When Ignition is Turned OFF	2/0	2
7WAZ	TAIL PIPE (1) Turnback Type	-11/-2	-13

<u>Code</u>	<u>Description</u>	<u>F/R Wt</u> (lbs)	<u>Tot Wt</u> (lbs)
ELECTRICAL SYSTEMS			
8000	ELECTRICAL SYSTEM 12-Volt, Standard Equipment <u>Includes</u> : HAZARD SWITCH Push On/Push Off, Located on Instrument Panel to Right of Steering Wheel : HEADLIGHT DIMMER SWITCH Integral with Turn Signal Lever : PARKING LIGHT Integral with Front Turn Signal and Rear Tail Light : STARTER SWITCH Electric, Key Operated : STOP, TURN, TAIL & B/U LIGHTS Dual, Rear, Combination with Reflector : WINDSHIELD WIPER SWITCH 2-Speed with Wash and Intermittent Feature (5 Pre-Set Delays), Integral with Turn Signal Lever : WINDSHIELD WIPERS Single Motor, Electric, Cowl Mounted	0/0	0
8GGG	ALTERNATOR {Delco Remy 36SI} Brushless, 12 Volt, 165 Amp Capacity, Pad Mount, with Remote Sense	7/0	7
8RPP	ANTENNA Shark Fin, Roof Mounted	1/0	1
8THB	BACK-UP ALARM Electric, 102 dBA	0/3	3
8VUK	BATTERY BOX Aluminum, with Plastic Cover, 18" Wide, 2-4 Battery Capacity, Mounted Right Side Back of Cab	0/0	0
8MJR	BATTERY SYSTEM {Fleertite} Maintenance-Free, (3) 12-Volt 2250CCA Total, Top Threaded Stud	9/3	12
8HAB	BODY BUILDER WIRING Back of Day Cab at Left Frame or Under Sleeper, Extended or Crew Cab at Left Frame; Includes Sealed Connectors for Tail/Amber Turn/Marker/ Backup/Accessory Power/Ground and Sealed Connector for Stop/Turn	3/0	3
8RJW	CB RADIO Omit Power Feeds, Power Source and Wiring	0/0	0
8XAH	CIRCUIT BREAKERS Manual-Reset (Main Panel) SAE Type III with Trip Indicators, Replaces All Fuses	0/0	0
8WXB	HEADLIGHT WARNING BUZZER Sounds When Head Light Switch is on and Ignition Switch is in "Off" Position	0/0	0
8XNZ	HEADLIGHTS Halogen, with Daytime Running Lights	0/0	0
8653	HORN, AIR Single, Located Under Cab	0/0	0
8VAY	HORN, ELECTRIC Disc Style	0/0	0
8WBW	JUMP START STUD 12V, Remote Mounted	2/0	2
8RPS	RADIO AM/FM/WB/Clock/Bluetooth/USB Input/Auxiliary Input	3/0	3
8RMV	SPEAKERS (2) 6.5" Dual Cone Mounted in Doors	0/0	0
8WXG	STARTING MOTOR {Mitsubishi Electric Automotive America 105P} 12-Volt, with Soft-Start	0/0	0
8WEZ	TURN SIGNAL SWITCH Self-Canceling	0/0	0
FRONT END			
9ASE	FRONT END Tilting, Composite	0/0	0
9WAC	BUG SCREEN Mounted Behind Grille	5/0	5

Code	Description	F/R Wt (lbs)	Tot Wt (lbs)
9585	FENDER EXTENSIONS Rubber	18/0	18
9HCL	GRILLE Black Vertical Accent Bars, with Black Mesh	0/0	0
9AAB	LOGOS EXTERIOR Model Badges	0/0	0
9AAE	LOGOS EXTERIOR, ENGINE Badges	0/0	0
SPEEDOMETER, TOOLS, MISC			
10AGB	CONNECTED PLATFORM Includes Connectivity Module and Five Year Data Plan	0/0	0
10060	PAINT SCHEMATIC, PT-1 Single Color, Design 100	0/0	0
10761	PAINT TYPE Base Coat/Clear Coat, 1-2 Tone	0/0	0
10WCY	SAFETY TRIANGLES	5/1	6
10NZL	SPECIAL RATING, GVWR Limited to 80,000-lb GVWR	0/0	0
FUEL TANKS			
15SWE	FUEL TANK Top Draw, Non-Polished Aluminum, 26" Dia, 70 US Gal (265L), Mounted Left Side, Under Cab	-5/7	2
15WEY	DEF TANK 10.8 US Gal (41L) Capacity, Frame Mounted Outside Left Rail, Under Cab	0/0	0
15LNA	FUEL HEATER PLUMBING {Cummins} Plumbing for Thermal Recirculation Valve (TRV) Mounted to Cummins X15 Engines, Thermostatically Controlled	0/0	0
15LPU	FUEL/WATER SEPARATOR {Racor 6600} Pre-Filter and Filter Base, Includes Water-in-Fuel Sensor	-3/0	-3
WHEELS, TIRES - FRONT			
27DBA	WHEELS, FRONT {Accuride 29374} DISC; 22.5x12.25 Rims, Extra Polish Aluminum, 10-Stud, 285.75mm BC, Hub-Piloted, Flanged Nut, with Steel Hubs	0/0	0
7752665441	(2) TIRE, FRONT 425/65R22.5 Load Range L HAC 3 (CONTINENTAL), 465 rev/mile, 68 MPH, All-Position	112/0	112
WHEELS, TIRES - REAR			
28DWT	WHEELS, REAR {Accuride 43644} DUAL DISC; 22.5x8.25 Rims, Extra Polish Aluminum, 10-Stud, 285.75mm BC, Hub-Piloted, Flanged Nut, with Steel Hubs	0/-232	-232
7372135444	(8) TIRE, REAR 11R22.5 Load Range G HDR2+ (CONTINENTAL), 491 rev/mile, 75 MPH, Drive	0/40	40
WHEELS, TIRES - LIFT AXLE			
34ADH	WHEELS, LIFT AXLE PUSHER {Accuride 43644} Single Wheels, For One Lift Axle; 22.5x8.25 Rims, Standard Polish Aluminum, 10-Stud, 285.75mm BC, Hub-Piloted, Flanged Nut << Pricing Includes Standard Tires >>	66/220	286
7792495439	(2) TIRE, PUSHER 295/75R22.5 Load Range H HSR 3 (CONTINENTAL), 514 rev/mile, 75 MPH, All-Position	0/0	0
BODY INTEGRATION			

<u>Code</u>	<u>Description</u>	<u>F/R Wt</u> (lbs)	<u>Tot Wt</u> (lbs)
60AKG	BDY INTG, PTO ACCOMMODATION for (3) Latched Rocker Switches, (1) PTO Switch, (2) Generic Switches to Control (3) 30 amp relays, with Programmable Interlocks, for Body Builder Hook up in the Engine Compartment Left Side, Recommended for Automatic Transmissions Cab schematic 100LZ Location 1: 9219, Winter White (Std) Chassis schematic N/A Services Section:	0/0	0

WARRANTY

40132	WARRANTY Standard for HX520, HX620, Effective with Vehicles Built January 1, 2021 or Later, CTS-2015B Total Component Weight:	0/0	0
		11435/8528 (lbs)	19963 (lbs)
1	Imperial Industries 5,000 Gallon Vac. Truck for Pineallas Co. Utilities Dept. with Additional Accessories Total Body Allied:	0/0	0
		0/0 (lbs)	0 (lbs)

The weight calculations included in this proposal are an estimate of future vehicle weight. The actual weight as manufactured may be different from the estimated weight. Navistar, Inc. shall not be liable for any consequences resulting from any differences between the estimated weight of a vehicle and the actual weight.

<u>Description</u>	<u>(US DOLLAR)</u>	<u>Price</u>
Net Sales Price:		\$311,407.00
Memo Item(s):		
Total Federal Excise Tax	\$0.00	
Total Taxes:	\$0.00	
Body/Allied Equipment:	\$119,334.00	
Note: Memo item(s) shown here are included in the above Net Sales Price.		

In accordance with Florida Sheriffs Association (FSA) contract FSA25-VEH23.0 valid from 10/1/2025 thru Sept. 30th, 2026. Orders placed must be able to build by 12/31/2026.

Acquisition cost can be secured if PO is received by 6/30/2026, and built by 12/31/2026.

NOTE: Chassis production can be expected to be 120 days from receipt of purchase order. Delivery of completed truck with body within 120 days of chassis build date.

Item# 77, 2027 International HX620 8x6 with options per contract: \$192,073.00
 Item# 77 Body Contract Option IMP-544076, 5,000 Gallon Imperial Tank, Pinellas Co. Spec: \$119,334.00

Total for complete Truck per FSA25-VEH23.0 Contract: \$311,407.00
 Florida State Sales Tax: N/A
 Hillsborough County Surtax: N/A
 Florida Tire & Battery Fee: Included
 Florida County Tag: Included

Total for one (1) unit per the above specifications and including Tire/Battery, County Tag and delivery: \$311,407.00

The TOPS FET Calculation is an estimate for reference purposes only. The seller is responsible for calculating and reporting/paying appropriate FET to the IRS.

The limited warranties applicable to the vehicles described here in are International Motors, LLC* standard printed warranties which are incorporated herein by reference and to which you have been provided a copy and hereby agree to their terms and conditions.

International Motors, LLC d/b/a International Motors USA LLC in Illinois and Ohio.

Exhibit D - Customization Options for Chassis - Item 77 HX620 6x4 Truck

Florida Sheriffs Association Cooperative Purchasing Program Options Template

Bidder: Sun State International Trucks, LLC

Item make & model: 2027 International HX620 SBA 6x4 Truck Chassis, FSA Bid effective 10/1/25 thru 9/30/26

Item number: Item 77, FSA25-VEH23.0. **Proposal #12530 for Pinellas County. 5,000 Gallon Imperial Tank**

Dated: 2/16/2026

Manufacturer Order Code	Price	Description	Factory or Vendor Installed?	Factory Invoice/MSRP Discount % (factory-installed)	Cost-Plus Markup % (vendor-installed)
Item #77	\$142,997	2027 International HX620 6x4 per FSA25-VEH23.0 Standard Specifications	Factory	20%	
DOT-01	\$227	Fire Extinguisher & Triangle Kit	Dealer		0.00%
DOT-02	\$126	Mudflaps	Dealer		0.00%
Tag-01	\$393	New County Tag	Vendor		0.00%
Tag-02	\$262	Transfer Tag	Vendor		0.00%
1CGC	\$161	120,000 PSI Frame Rails, 12.250" x 3.380" x 0.375"	Factory	20%	
1CGD	\$1,809	125,000 PSI Frame Rails, 12.50" x 3.75" x 0.500"	Factory	20%	
1GBP	\$1,908	Outer "C" Channel Frame Reinforcement, 120K PSI, 10.813" x 3.892" x 0.312	Factory	20%	
1LEH	\$24	Front License Plate Holder	Factory	20%	
1AMS	\$213	Cross Member Frame Tie, For Heavy Duty	Factory	20%	
1WRW	\$122	(2) Front Tow Hooks, 80,000 lb. Capacity	Factory	20%	
1SAP/SAR	\$250	5-piece Rear Crossmember(s) After Frame	Factory	20%	
1WXL	\$685	Wheelbase Range 191" through and including 236"	Factory	20%	
1WXM	\$1,313	Wheelbase Range 238" through and including 295"	Factory	20%	
2ASM/3ACP	\$1,259	Meritor Wide Track 14,600-lb Capacity Front Axle, Suspension w/Shocks	Factory	20%	
2ARU/3ACP	\$1,798	Meritor Wide Track 16,000-lb Capacity Front Axle, Suspension w/Shocks	Factory	20%	
2ARZ/3ADG	\$1,977	Meritor Wide Track 18,000-lb Capacity Front Axle, Suspension w/Shocks	Factory	20%	
2ARY/3AGA	\$2,610	Meritor Wide Track 20,000-lb Capacity Front Axle, Suspension w/Shocks	Factory	20%	
3770	\$92	Front Suspension Auxiliary Rubber Springs	Factory	20%	
4AZS	\$1,433	Bendix ABS w/Electronic Stability & Auto Traction Control, 4-Channel	Factory	20%	
4AZV	\$393	6-Channel Bendix ABS with Auto Traction Control			
4AZY	\$1,995	6-Channel Bendix ABS with Electronic Stability Programming & Auto Traction Control			
4WBX/WDM	\$87	Dust Shields for Air Cam Brakes, front & rear	Factory	20%	
4WRJ	\$103	Compressor Discharge Line to Air Dryer, Teflon Hose, w/ Stainless Steel Braid	Factory	20%	
4EYD	\$47	Air Dryer Shield to protect from Debris	Factory	20%	
4WZJ	\$414	Air Tanks mounted Under Each Rail, Front of Rear Suspension, Parallel to Rail	Factory	20%	
4WZW	\$1,241	Air Tanks Stacked, Outside Left Rail, Back of Cab, Perpendicular to Rail	Factory	20%	
4WYZ	\$208	Bendix DV-2 Drian Valves, (2) Auto, w/Heater, (2) Berg, with Pull Chains, for Air Tanks	Factory	20%	
4619	\$446	Straight Truck Trailer Connections, Hand Control & Tractor Protection Valves	Factory	20%	
5PTB	\$953	Sheppard Dual Steering Gear M100/M80 Dual Power			
5PUA	\$1,841	Sheppard Dual Sterring Gear M110/M80 Dual Power			
6DGX	\$162	Dana Spicer Service Free SPL250 Main Driveline, PL170 Interaxle Shaft	Factory	20%	
7BLX	\$2,810	Vertical Aftertreatment System, Frame Mounted Right Side Back of Cab, for Single Vertical Tail Pipe	Factory	20%	
7BMY	\$1,036	Horizontal Aftertreatment System, Right Side Back of Cab, Single Vertical Tail Pipe, Twin Steer Application	Factory	20%	
7WBU/WCK	\$119	Exhaust Height 11'6" or 12'6" with turn back tailpipe	Factory	20%	
7WAZ	\$53	Turn Back Tail Pipe	Factory	20%	
7WBA	\$172	Bright Turn Back Tail Pipe	Factory	20%	
8GGG	\$280	Delco Remy 36SI Brushless Alternator, 165 Amp., Remote Voltage Sensor	Factory	20%	
8GHJ	\$1,034	Delco Remy 40SI Brushless Alternator, 165 Amp., Remote Voltage Sensor	Factory	20%	
8GXC	\$993	Leece-Neville BLP4006HN Brushless Alternator, 325 Amp., Remote Sense	Factory	20%	
8VJV	\$565	Battery Box, Aluminum, Plastic Cover, 18" Wide, 2-4 Batteries, Right Side 49" Back of Cab	Factory	20%	
8VVP	\$1,861	Battery Box, Aluminum, w/Aluminum Cover, 10.5" Wide, 2-3 Batteries, Right Side 14" Back of Cab	Factory	20%	
8XDZ	\$925	Battery Box, Steel, 2-3 Batteries, Mounted In Cab, Under Passenger Seat	Factory	20%	
8WJN	\$138	Battery Box, Aluminum, 30" Wide, 2-4 Batteries, Mounted Left Side Under Cab	Factory	20%	
8WWD	\$597	Battery Box Cover, Stainless Steel, Bright Finish	Factory	20%	
8WYU	\$48	Rubber Pad Added Inside Bottom of Battery Box	Factory	20%	
8MJR	\$104	Battery System, (3), 2250CCA Total	Factory	20%	
8MSH	\$261	Battery System, (4), 2640CCA Total	Factory	20%	
8MRR	\$1,155	Battery System, Enersys Odyssey 31-PC2150 AGM, (3) AGM 12-Volt, 3450CCA Total	Factory	20%	
8XLZ	\$361	Beacon Lights, (2) LED, Cab Mounted, Stainless Mounting Brackets, Wiring, and Switch on Dash	Factory	20%	
8HAA	\$269	Body Builder Wiring to Rear of Frame, with Stop, Tail, Turn, and Marker Lights Circuits, Ignition Controlled Auxiliary Feed and Ground, Less Trailer Socket	Factory	20%	
8HAE	\$172	Body Builder Wiring to Rear of Frame; Includes Sealed Connectors for Tail/Amber Turn/Marker/ Backup/Accessory Power/Ground and Sealed Connector for Stop/Turn	Factory	20%	
8HAH	\$299	Trailer Brake/Light Accomodation Pkg. to Rear of Frame; for Combined Trailer S/T/T	Factory	20%	
8XMZ	\$107	(2) RP1226 Connectors Located Behind Instrument Panel Center Console	Factory	20%	
8XJH	\$227	Fog Lights, (2) Clear Lens Rectangular LED	Factory	20%	
8XKC	\$67	Headlights: Halogen, w/Daytime Running Lights, Auto Twilight Controlled	Factory	20%	
8WRB	\$35	Headlights Will Automatically Turn On if Windshield Wipers are Turned On	Factory	20%	
8WBW	\$139	JUMP START STUD Remote Mounted	Factory	20%	
8XPL	\$139	(2) APO, (2) USB-A Port & (2) USB-C Port in the Instrument Panel	Factory	20%	
8RPS	\$95	Radio: AM/FM/WB/Clock/Bluetooth/USB Input/Auxiliary Input	Factory	20%	

8RPB/XHX	\$108	Radio & Headlight Controls in Steering Wheel w/Bluetooth Answer/Disconnect	Factory	20%
8RMZ	\$74	(2) 6.5" Speakers Mounted in Doors, (2) 5.25" in B-Pillars	Factory	20%
8TKJ	\$398	Truck Lite Super 44 LED for Stop, Turn, Tail and BU Lights	Factory	20%
8WPZ	\$35	Pre-Trip Inspection to Cycle all Exterior Lamps Except Back-up Lights	Factory	20%
8TKK	\$102	Circuit for Electric Trailer Brake Accommodation/Air Trailer ABS	Factory	20%
8TMG	\$361	Trailer Connection Socket, 7-Way, Rear of Frame, Compatible with Trailers with Combined S/T/T Lamps	Factory	20%
8THB	\$99	Back Up Alarm, 102 dBA	Factory	20%
8WXD	\$35	Parking Brake Alarm	Factory	20%
9WAC	\$108	Bug Screen Mounted Behind Grille	Factory	20%
9585	\$86	Rubber Fender Extensions	Factory	20%
12EWW	\$410	Cummins X15 450 V Productivity Series, EPA 2024, 450HP @ 1900 RPM, 1650 lb-ft Torque	Factory	20%
12EWY	\$731	Cummins X15 470 Productivity Series, EPA 2024, 470HP @ 1950 RPM, 1750 lb-ft Torque	Factory	20%
12EXJ	\$2,370	Cummins X15 525 Performance Series, EPA 2024, 525HP @ 1950 RPM, 1850 lb-ft Torque	Factory	20%
12VGA/U	\$77	Remote Mounted Engine Control for PTO	Factory	20%
12XCM	\$3,157	Rear Engine PTO, with SAE 1410 Flange, for S13 Engine (Ratio 1.2:1)	Factory	20%
13BDY	\$16,951	Allison 4000 RDS Automatic Transmission, 5th Gen, Close Ratio, 6-Speed. Includes 13WHL Transmission Oil Cooler, 13WLM Synthetic Transmission Fluid, 13WVV Neutral at Stop, 13WET Column Mounted Shifter	Factory	20%
13BEK	\$19,574	Allison 4500 RDS Automatic Transmission, 5th Gen, Wide Ratio, 6-Speed. Includes 13WHL Transmission Oil Cooler, 13WLM Synthetic Transmission Fluid, 13WVV Neutral at Stop, 13WET Column Mounted Shifter, 16DYE Access Cover	Factory	20%
13WDM	\$8,019	Hydraulic Retarder For Allison 4000 Series Transmission	Factory	20%
13XAA/WDN	\$288	Dash Mounted PTO Controls	Factory	20%
14GVL	\$1,645	Meritor MT-40-14X-4DCR Rear Axles, 40K Cap., Lube Pump, Locking Diff Both axles	Factory	20%
14GRP	\$4,349	Meritor RT-46 Tandem Axles, 46K lb Capacity, locking Dif. in Rear/Rear Axle	Factory	20%
14HRE	\$5,223	Meritor RT-46-164P Rear Axles, 46K-lb Cap., Lube Pump, Locking Diff Both Axles, includes 14WMK synthetic axle oil.	Factory	20%
14ULU	\$672	Hendrickson HAS-402-55 Rear Air Suspension, 40K-lb Cap., 55" Spacing	Factory	20%
14ULT	\$1,281	Hendrickson HAS-460-55 Rear Air Suspension, 46K-lb Cap., 55" Spacing	Factory	20%
14UNX	\$2,793	Hendrickson PRIMAAAX EX Rear Air Suspension, 46K-lb Cap., 55" Spacing	Factory	20%
14UHK	\$410	Hendrickson RT-463 Rear Suspension, Walking Beam, 46K-lb Cap. 54" Axle	Factory	20%
14UMV	\$1,099	Hendrickson HMX-400-54 Walking Beam, 40K-lb Cap., 54" Spacing	Factory	20%
14UMX	\$1,835	Hendrickson HMX EX 460 Walking Beam, 46K-lb Cap., 54" Spacing	Factory	20%
14UZB	\$3,238	Chalmers 854-46H-HS Walking Beam Suspension, 46K-lb Cap., 54" Spacing	Factory	20%
14UZS	\$2,756	Chalmers 854-40L Walking Beam, 40K-lb Cap., 54" Spacing	Factory	20%
14WLM	\$10,320	Watson & Chalin AL-2200 Pusher Lift Axle, 20K-lb Capacity, Non-Steerable Lift Axle	Factory	20%
14WNK/H	\$10,453	Watson & Chalin SL1190SSR Tru-Trk Alumilite, 13,500-lb Cap, Self-Steer Lift Axle	Factory	20%
14WNM	\$13,530	Watson & Chalin SL-2065 Tru-Track, 20,000-lb Cap., Self-Steer Lift Axle	Factory	20%
34ACJ	\$1,174	Wheels & Tires for Lift Axle: Accuride Powerder Coated Steel & Continental 295/75R22.5 HSR 3 Regional/All-Position	Factory	20%
14RAR	\$895	Lift Axle Controls, Controls Inside and Outside Cab; Includes Lift/Lower Switch Inside Cab on Dash; Pressure Gauge and Pressure Regulator Outside Cab	Factory	20%
14WMK	\$102	Rear Axle Lube, Synthetic, EmGard FE-75W-90, 65 thru 89.99 Pints	Factory	20%
14WBN	\$218	(2) Differential Switch controls in dash, one for each locking rear differential	Factory	20%
14WBV/U	\$722	(4) Shocks for Hendrickson HMX or Chalmers Suspensions, Mounted Frame to Beam	Factory	20%
14862	\$42	Rear Axle Power Divider Lock Warning Buzzer	Factory	20%
14WCP	\$142	Hendrickson TRAAX Torque Rods, Longitudinal Only, for suspension	Factory	20%
14WCR	\$142	Hendrickson TRAAX Torque Rods, Transverse Only, for suspension	Factory	20%
14899	\$135	Rear Air Suspension Release Valve (Dump Valve)	Factory	20%
15SGL	\$291	80-Gallon Fuel Tank, Left side under cab	Factory	20%
15SHC	\$509	100-Gallon Fuel Tank, Left side under cab	Factory	20%
15WEZ	\$119	18-Gallon DEF Tank, Frame Mounted Outside Left Rail, Under Cab	Factory	20%
15LPW	\$360	Davco 386 Fuel Water Separator, Heated, Water-in-Fuel Sensor	Factory	20%
16ATC	\$81	Automatic Climate Control, Maintains Cabin Comfort Based on Selected Temperature	Factory	20%
16WLS	\$63	Fresh Air Filter for Intake Cover on Cowl Tray in Front of Windshield Under Hood	Factory	20%
16LWX	\$158	Drivers Seat, Air Suspension, High Back, Vinyl, Double Chamber Lumbar, Heat, Inboard Armrest, Suspension Cover, Fore/Aft Isolator, Cushion Extension, Cushion Tilt, Seat Tilt, Memory Quickdown	Factory	20%
16SRZ	\$1,094	Passenger Seat, Air Suspension, High Back, Vinyl, Double Chamber Lumbar, Heat, Inboard Armrest, Suspension Cover, Fore/Aft Isolator, Cushion Extension, Cushion Tilt, Seat Tilt, Memory Quickdown	Factory	20%
16GHU	\$28	Interior Grab Handles Painted Safety Yellow		
16SNS	\$345	Pedestal Cab Mirrors, Powered, Heated, Black, w/Convex	Factory	20%
16SNT	\$59	Pedestal Cab Mirrors, Powered, Heated, Black, Integrated Turn Signals, w/Convex	Factory	20%
16HCS	\$500	Ambient Temperature Gauge	Factory	20%
16SNW	\$41	Look Down Mirror, Passenger Side Above Door, 6" x 10.5"	Factory	20%
16HCH	\$47	Seatbelt Warning Indicator Light & Alarm	Factory	20%
16VCC	\$22	Orange Seat Belts	Factory	20%
16SPA	\$176	(2) Hood Mounted Mirrors, Black 7.5" Sq.	Factory	20%
16XWV	\$287	Sunshade with Integral Clearance/Marker Lights	Factory	20%
16XYW	\$306	Day Can Interior Noise Reduction Package	Factory	20%
16UZJ	\$42	Storage Pocket Rear Wall between seats	Factory	20%
29ACD	\$20	Flo-Thru Design Tite Valve Caps	Factory	20%

29CAE	\$73	Stemco Sentinal Vented Front Hub Caps	Factory	20%	
27DYH	\$218	Accuride 22.5 x 9.00 Rims, Powder Coat Steel, 5-Hand Hole, 10-Stud, Steel Hubs	Factory	20%	
27DBA	\$869	Accuride 22.5" x 12.25" Aluminum Front Wheels, 10-Stud, Steel Hubs			
7792655441	\$287	Continental 385/65R22.5, LR-L, HAC 3 Steer Tires (For 18K Front Axles), includes 9585 Front Fender Extensions	Factory	20%	
7752665441	\$329	Continental 425/65R22.5, LR-L, HAC 3 Steer Tires (For 20K Front Axles), includes 9585 Front Fender Extensions	Factory	20%	
7372135444	-\$491	Continental 11R22.5, LR-G, HDR2+ Drive Tires	Factory	20%	
7382155439	\$574	Continental 12R22.5, LR-H HSR-3 Steer Tires	Factory	20%	
60AAG/ALV	\$650	Mounted Inside Cab Behind Driver Seat, Up to 6 Outputs & 6 Inputs, Max 20 amp per Channel, Max 80 amp Total; Includes 1 Switch Pack Containing 6 Latched or Momentary Switches	Factory	20%	
60AJK	\$74	(2) Indicator Lights: 1 for Body Up, 1 for Gate Open, Includes Audible Alarm, Programmable Mode for Various Switch Actions. (Requires 2 Remote Power Module Inputs)	Factory	20%	
60AKK	\$221	Programming: High Beam Wig Wag with Park Brake Interlock, Park Brake Disables Wig Wag	Factory	20%	
60AKG	\$122	PTO Accomodation: for (3) Latched Rocker Switches, (1) PTO Switch, (2) Generic Switches to Control (3) 30 amp relays, with Programmable Interlocks, for Body Builder Hook up in the Engine Compartment Left Side, Recommended for Automatic Transmissions	Factory	20%	

\$142,997	FSA Item #77 Base Price
\$49,076.00	FSA Item# 77 plus options Highlighted above under FSA25-VEH23.0
\$119,334.00	FSA Contract Option Body; IMP-544076 Highlighted in Yellow Below. Pinellas Co. Spec
\$311,407.00	<i>PO Total for base chassis + options + body</i>

Body Vendor Options					
IMP-544076	\$119,334	Imperial Industries TMV5000A 5,000 Gallon Septic Vacuum Truck Body, 4310 Blower, Chelsea PTO for 4500 RDS. Requires 79,600 GVW (6x4 w/liftaxle for 8x6). Pinellas County Specification. Detailed Specs provided upon request.	Vendor		1.25%

Exhibit E - 5000-gallon Imperial Tank Quote



QUOTE: 544076-01 Pinellas Co. Utilities Body Spec.

Reference: TMV5000A International HX 4310

QUOTATION REMAINS VALID FOR 15 DAYS FROM QUOTE DATE UNLESS OTHERWISE NOTED.

Accessories						
Item	Part Number	Quantity	UOM	Description	Price Each	Price Total
10	805022	1	EA	TMV5000 (ALUM) COMPLETE ASSEMBLY WITH 4310 BLOWER - Rib Free Exterior. - 1/4" 5454 Barrel. - 5/16" 5454 ASME Dished Heads. - Full Length Skids with Rubber Sills - (3) Full Flanged & Dished Heads For Baffles. - (4) 6" Interior Channel Ribs. - Full Doubler Plate (Bottom 1/3rd of Tank Double Plated) - Hose Trays W/Rear Tail Light Sections. - Primary 12" x 4" With Internal Airline. - 20" Top Manway . - 20" Rear Manway . - 6" Discharge Port, Flanged. W/Piston Valve, Manual Handle and Camlocks - 4" Intake Port, Flanged. W/Lever Valve and Camlocks - (2) Hose Hooks. - (2) Hose Guards. - Ladder. - (3) 5" Sight Glasses. - Toolbox, 24"X24"X36" Aluminum. - LED DOT Light Kit. Marker/Stop/Tail/Signal/2 Work Lights - (4) Mud flaps. - 2"x6" Rear Bumper. - Chelsea Hot Shift PTO. - 3" Tubular Drive Shaft - NVE 4310 Blower Package. (920 CFM) - PTO, RPM, Work Light Controls on Floor by Driver Door - 8 Mount Spring Mounting Kit.		\$76,483.34
						\$300.00
						\$5,000.00
						\$1,000.00
						\$500.00
						\$1,000.00
						\$500.00
						\$500.00
						\$1,000.00
						\$600.00
						\$450.00
						\$450.00
						\$1,000.00
						\$2,050.00
						\$150.00
						\$150.00
						\$450.00
						\$300.00
						\$850.00
						\$1,050.00
						\$250.00
						\$750.00
						\$2,900.00
						\$500.00
						\$9,000.00
						\$500.00
						\$2,050.00
20	809168.TM	1	EA	DOT KIT FOR SEPTIC TRUCK MOUNT		\$0
30	121727.25	1	EA	PTO,CHELSEA (3000RDS) (161%) (4307 & 4310)		\$0

Chris Harris
Let's Get You Going!
 Truck Sales Representative
 Sun State International Trucks LLC
 6020 Adamo Dr Tampa FL 33619
chris.harris@sunstateintl.com
 Phone: 813-621-1331 x1018
 Mobile: 813-760-8550





INTERNATIONAL



QUOTE: 544076-01 Additional Accessories Per Pinellas Co. Body Spec.

Accessories						
Item	Part Number	Quantity	UOM	Description	Price Each	Price Total
40	PROGRAMMING	1	EA	PROGRAMMING		\$0
50	815020	1	EA	WIRING FOR DATA LINK CONTROLLER		\$0
60	815017	1	EA	RELAY CONTROLLER		\$0
70	102383.7	10	EA	LIGHT, MINI AMBER STROBE LED		\$2,192.90
80	809529	1	EA	ROAD CONE HOLDER WELDMENT BOLT-ON UNDER HOSE TRAY (ALUM)		\$308.64
90	PURCHASED	2	EA	AMBER LED ARROW LIGHTS		\$2,559.92
100	815012.4	1	EA	CAMERA, REAR VIEW MIRROR (OPTIMO OP31HD & OP 8801-CD MIRROR)		\$1,649.67
110	PURCHASED	4	EA	3" 300 EPDM HOSE WITH ENDS 40'		\$1,859.76
120	PURCHASED	2	EA	3" 300 EPDM HOSE WITH ENDS 20'		\$929.88
130	101064	1	EA	CAM-LOCK, 4" COUPLER X 3" ADAPTOR (ALUM)		\$99.89

Quote Sub Total: \$119,334.00

Fet Tax: \$0.00

Sales Tax: \$0.00

Estimated Total Freight: \$0.00

Quote Total: \$119,334.00

[Click here for your finance application](#)

Chris Harris

Let's Get You Going!

Truck Sales Representative
Sun State International Trucks LLC
6020 Adamo Dr Tampa FL 33619
chris.harris@sunstateintl.com
Phone: 813-621-1331 x1018
Mobile: 813-760-8550



FSA Cooperative Purchasing Program



FSA25-VEH23.0: Heavy Trucks and Buses Contract Packet



PROTECTING, LEADING & UNITING SINCE 1893

FLORIDA SHERIFFS ASSOCIATION

2617 Mahan Drive
Tallahassee, Florida 32308

p: (850) 877-2165 f: (850) 878-8665
flsheriffs.org    

NOTICE OF FINAL AWARD CONTRACT FSA25-VEH23.0: Heavy Trucks

Date: October 1, 2025

To: All Prospective Bidders and Purchasers

From: Matt Dunagan, Executive Director
Sarrah Glassner, Deputy Executive Director of Administration
Megan Taber, Cooperative Purchasing Program Director

Re: Contract Number FSA25-VEH23.0 Heavy Trucks: Contract Awards

We are pleased to announce that the Florida Sheriffs Association (FSA) has successfully completed its latest nationwide cooperative bid for Heavy Trucks. This contract is in effect beginning October 1, 2025, through September 30, 2027.

This notification is for the Florida Sheriffs Association (FSA), Cooperative Purchasing Program (CPP) Intent to Award for contract FSA25-VEH23.0 : Heavy Trucks. All bids were received in a timely manner, reviewed, and evaluated by the FSA and its Fleet Advisory Committee.

The contract specifications include:

- Buses Electric: 19 to 20 Passenger Capacity Range, Van-Type Cutaway Chassis
- Buses Electric: 20 to 52 Passenger Capacity Range, Conventional-Type Chassis
- Buses Electric: 44 To 80 Passenger Capacity Range, Commercial-Type Chassis
- Buses: 14 to 25 Passenger Capacity Range, Van-Type Cutaway Chassis
- Buses: 20 to 52 Passenger Capacity Range, Conventional Truck-Type Cutaway Chassis
- Buses: 33 to 54 Passenger Capacity Range, Commercial-Type, Rear Engine Chassis
- Buses: 36 to 52 Passenger Capacity Range, Commercial-Type, Front Engine Chassis
- Cab and Chassis Trucks Electric: 54,000 lbs. GVWR 4x6 Semi Tractor
- Cab and Chassis Trucks Electric: Conventional Cab 33,000 lbs. GVWR (DRW) 4x2
- Cab and Chassis Trucks Electric: Tilt Cab 26,000 lbs. GVWR (DRW) 4x2
- Cab and Chassis Trucks: 17,500 lbs. GVWR (DRW) 4x2
- Cab and Chassis Trucks: 17,500 lbs. GVWR (DRW) 4x4
- Cab and Chassis Trucks: 25,500 lbs. GVWR (DRW) 4x2

- Cab and Chassis Trucks: 30,000 lbs. GVWR (DRW) 4x2
- Cab and Chassis Trucks: 52,000 lbs. GVWR Semi Tractor 4x6
- Cab and Chassis Trucks: 52,000 lbs. GVWR Truck 4x6
- Cab and Chassis Trucks: 12,000 lbs. GVWR (DRW) 4x2 Tilt Cab
- Cab and Chassis Trucks: 25,000 lbs. GVWR (DRW) 4x2 Tilt Cab
- Refuse Truck Electric: 60,000 lbs. GVWR 4x6 (cab and chassis only)
- Refuse Truck: 60,000 lbs. GVWR 4x6 (cab and chassis only)
- Refuse Truck: Compact 9.5 Cubic Yds. Self-Loading Refuse Truck
- Tactical Armored Vehicles
- Terminal Tractor
- Spray Truck: 19,500 lbs. GVWR 4x2, Mounted 1,000 gal ROW Spray Unit
- Utility Truck: 33,000 lbs. GVWR 4x4, Digger Derrick
- Utility Truck: 33,000 lbs. GVWR 4x4, Mounted Aerial Device

The competitive process for this award began in March of 2025, when FSA Fleet Advisory Committee, bidders, and stakeholders provided input regarding heavy truck and equipment procurement needs. Specifications were developed based on prior years activity, and new additions were included based on feedback from the FSA Committee, bidders, and stakeholders.

Advertisements of the Invitation to Bid (ITB) were placed on the FSA website on March 28, 2025, and within the Florida Administrative Register on March 28, 2025, and May 1, 2025.

From the ITB, 40 bidders completed the pre-bid process. Of these respondents, 34 submitted bids. 28 responsive bidders were awarded after bids were evaluated by the FSA Fleet Advisory Committee and FSA staff.

The Florida Sheriffs Association Cooperative Purchasing Program has followed the Contract Terms and Conditions to procure this contract.

Contract prices are extended and guaranteed to any local government or political subdivision of the state, public educational institutions, other public agencies or authorities with the State of Florida, and other entities approved by the manufacturer to participate in this contract.

Out-of-state sales are permitted under this contract. All purchasers are bound by their local governing purchasing ordinances, rules and regulations.

All awarded vendors are governed by their manufacturer agreements and the Contract Terms and Conditions.

List of Intended Awards in Alphabetical Order:

- All Roads Kenworth, LLC.
- Altec Industries, Inc.
- Bachrodt FT, LLC. Dba Palmetto Ford of Miami
- Beck Chrysler Dodge Jeep

- Bozard Ford
- Broyhill Equipment, LLC.
- Container Systems & Equipment Co., Inc.
- Cumberland International Trucks of Florida
- DeLand Truck Center, Inc.
- Duval Ford, LLC.
- Florida Kenworth, LLC.
- Florida Transportation Systems, Inc.
- Kenworth of Jacksonville
- Matthews Bus Alliance, Inc.
- Model 1 Commercial Vehicles, Inc.
- Nextran Truck Centers
- Orlando Freightliner
- Ottawa Trucks Center, Inc.
- RDK Assets, Inc.
- Rehtien International Trucks
- Ring Power Corporation
- Rush Truck Centers of Florida, Inc.
- SBL Freightliner, LLC.
- Sun State International Trucks
- Tampa Truck Center
- Terradyne Armored Vehicles, Inc.
- The Peterbilt Store South Florida, LLC.
- Truckmax, Inc.

The final award page document for all awarded bid items is attached.

FSA Cooperative Purchasing Program



**FSA25-VEH23.0: Heavy Trucks and Buses
Awarded Vendor Contract Signature Pages**



CONTRACT SIGNATURE FORM

By submitting a response to this Invitation to Bid and signing this form, the Bidder declares that he or she has read, and the company understands, accepts and will comply with the terms, conditions and specifications of this bid and any addenda issued. The failure or omission to review this document shall in no way relieve the authorized agent of obligations with respect to this bid. The submission of a bid and signature below shall be taken as evidence of acceptance of the terms and conditions of this bid.

The Bidder further declares that no other persons other than the authorized agent herein named has any interest in this bid or in the contract to be taken, and that it is made without any connection with any other person or persons making proposal for the same article, and is in all respects fair and without collusion or fraud.

The Bidder further declares that they have carefully examined the specifications and is thoroughly familiar with its provisions and with the quality, type and grade of materials required.

The Bidder further declares that they have provided a discount on all factory options included in this bid, and such discount will be included in all purchase orders.

The Bidder further declares that the company understands the financial responsibility associated with this bid as stated and further declares that it has the ability to meet the financial responsibility associated with this bid.

The Bidder further declares that the company will furnish the items awarded for the price bid.

FSA Contract Number FSA25-VEH23.0: Heavy Trucks and Buses

Bidder Company Name All Roads Kenworth LLC

Business Address 2909 S Andrews Ave
Fort Lauderdale, FL 33316

Name of Authorized Agent Michael Crawford

Email address of authorized agent mcrawford@allroadstrucks.com

Signed by:
Signature *Michael Crawford*
5F3AF30D0BFB47B...

Date 9/27/2025

FSA Contract Number

FSA25-VEH23.0: Heavy Trucks and Buses

Bidder Company Name All Roads Kenworth LLC



CONTRACT SIGNATURE FORM

By submitting a response to this Invitation to Bid and signing this form, the Bidder declares that he or she has read, and the company understands, accepts and will comply with the terms, conditions and specifications of this bid and any addenda issued. The failure or omission to review this document shall in no way relieve the authorized agent of obligations with respect to this bid. The submission of a bid and signature below shall be taken as evidence of acceptance of the terms and conditions of this bid.

The Bidder further declares that no other persons other than the authorized agent herein named has any interest in this bid or in the contract to be taken, and that it is made without any connection with any other person or persons making proposal for the same article, and is in all respects fair and without collusion or fraud.

The Bidder further declares that they have carefully examined the specifications and is thoroughly familiar with its provisions and with the quality, type and grade of materials required.

The Bidder further declares that they have provided a discount on all factory options included in this bid, and such discount will be included in all purchase orders.

The Bidder further declares that the company understands the financial responsibility associated with this bid as stated and further declares that it has the ability to meet the financial responsibility associated with this bid.

The Bidder further declares that the company will furnish the items awarded for the price bid.

FSA Contract Number FSA25-VEH23.0: Heavy Trucks and Buses

Bidder Company Name Altec Industries, Inc.

Business Address 210 Inverness Center Pkwy
Birmingham, AL 35242

Name of Authorized Agent Brooklyn Russell

Email address of authorized agent contractmanagement@altec.com

Signed by:
Signature *Brooklyn Russell*
EF524702A8584A8...

Date 9/25/2025

FSA Contract Number

FSA25-VEH23.0: Heavy Trucks and Buses

Bidder Company Name Altec Industries, Inc.



CONTRACT SIGNATURE FORM

By submitting a response to this Invitation to Bid and signing this form, the Bidder declares that he or she has read, and the company understands, accepts and will comply with the terms, conditions and specifications of this bid and any addenda issued. The failure or omission to review this document shall in no way relieve the authorized agent of obligations with respect to this bid. The submission of a bid and signature below shall be taken as evidence of acceptance of the terms and conditions of this bid.

The Bidder further declares that no other persons other than the authorized agent herein named has any interest in this bid or in the contract to be taken, and that it is made without any connection with any other person or persons making proposal for the same article, and is in all respects fair and without collusion or fraud.

The Bidder further declares that they have carefully examined the specifications and is thoroughly familiar with its provisions and with the quality, type and grade of materials required.

The Bidder further declares that they have provided a discount on all factory options included in this bid, and such discount will be included in all purchase orders.

The Bidder further declares that the company understands the financial responsibility associated with this bid as stated and further declares that it has the ability to meet the financial responsibility associated with this bid.

The Bidder further declares that the company will furnish the items awarded for the price bid.

FSA Contract Number FSA25-VEH23.0: Heavy Trucks and Buses

Bidder Company Name Bachrodt FT, LLC dba Palmetto Ford of Miami

Business Address 7245 NW 36th Street, Miami, FL. 33166

Name of Authorized Agent Charlie Rodgers

Email address of authorized agent crodgers@palmettofordtrucks.com

Signature Signed by:
Charlie Rodgers
1C63450A9FFF413...

Date 9/26/2025

FSA Contract Number

FSA25-VEH23.0: Heavy Trucks and Buses

Bidder Company Name Bachrodt FT, LLC dba Palmetto Ford of Miami



CONTRACT SIGNATURE FORM

By submitting a response to this Invitation to Bid and signing this form, the Bidder declares that he or she has read, and the company understands, accepts and will comply with the terms, conditions and specifications of this bid and any addenda issued. The failure or omission to review this document shall in no way relieve the authorized agent of obligations with respect to this bid. The submission of a bid and signature below shall be taken as evidence of acceptance of the terms and conditions of this bid.

The Bidder further declares that no other persons other than the authorized agent herein named has any interest in this bid or in the contract to be taken, and that it is made without any connection with any other person or persons making proposal for the same article, and is in all respects fair and without collusion or fraud.

The Bidder further declares that they have carefully examined the specifications and is thoroughly familiar with its provisions and with the quality, type and grade of materials required.

The Bidder further declares that they have provided a discount on all factory options included in this bid, and such discount will be included in all purchase orders.

The Bidder further declares that the company understands the financial responsibility associated with this bid as stated and further declares that it has the ability to meet the financial responsibility associated with this bid.

The Bidder further declares that the company will furnish the items awarded for the price bid.

FSA Contract Number FSA25-VEH23.0: Heavy Trucks and Buses

Bidder Company Name BECK CHRYSLER DODGE JEEP

Business Address 256 HWY 17 NORTH PALATKA FL 32177

Name of Authorized Agent Brandy Sloan

Email address of authorized agent contractinfo@beckfleet.com

Signed by:
Signature *Brandy Sloan*
C989DAD713D6403...

Date 9/29/2025

FSA Contract Number

FSA25-VEH23.0: Heavy Trucks and Buses

Bidder Company Name BECK CHRYSLER DODGE JEEP



CONTRACT SIGNATURE FORM

By submitting a response to this Invitation to Bid and signing this form, the Bidder declares that he or she has read, and the company understands, accepts and will comply with the terms, conditions and specifications of this bid and any addenda issued. The failure or omission to review this document shall in no way relieve the authorized agent of obligations with respect to this bid. The submission of a bid and signature below shall be taken as evidence of acceptance of the terms and conditions of this bid.

The Bidder further declares that no other persons other than the authorized agent herein named has any interest in this bid or in the contract to be taken, and that it is made without any connection with any other person or persons making proposal for the same article, and is in all respects fair and without collusion or fraud.

The Bidder further declares that they have carefully examined the specifications and is thoroughly familiar with its provisions and with the quality, type and grade of materials required.

The Bidder further declares that they have provided a discount on all factory options included in this bid, and such discount will be included in all purchase orders.

The Bidder further declares that the company understands the financial responsibility associated with this bid as stated and further declares that it has the ability to meet the financial responsibility associated with this bid.

The Bidder further declares that the company will furnish the items awarded for the price bid.

FSA Contract Number FSA25-VEH23.0: Heavy Trucks and Buses

Bidder Company Name Bozard Ford Co

Business Address 540 Outlet Mall Blvd
St. Augustine, FL 32084

Name of Authorized Agent Jeff Young

Email address of authorized agent jyoung@bozard.com

Signed by:
Signature 
95278DB5FBF54E7...

Date 9/26/2025

FSA Contract Number

FSA25-VEH23.0: Heavy Trucks and Buses

Bidder Company Name Bozard Ford Co



CONTRACT SIGNATURE FORM

By submitting a response to this Invitation to Bid and signing this form, the Bidder declares that he or she has read, and the company understands, accepts and will comply with the terms, conditions and specifications of this bid and any addenda issued. The failure or omission to review this document shall in no way relieve the authorized agent of obligations with respect to this bid. The submission of a bid and signature below shall be taken as evidence of acceptance of the terms and conditions of this bid.

The Bidder further declares that no other persons other than the authorized agent herein named has any interest in this bid or in the contract to be taken, and that it is made without any connection with any other person or persons making proposal for the same article, and is in all respects fair and without collusion or fraud.

The Bidder further declares that they have carefully examined the specifications and is thoroughly familiar with its provisions and with the quality, type and grade of materials required.

The Bidder further declares that they have provided a discount on all factory options included in this bid, and such discount will be included in all purchase orders.

The Bidder further declares that the company understands the financial responsibility associated with this bid as stated and further declares that it has the ability to meet the financial responsibility associated with this bid.

The Bidder further declares that the company will furnish the items awarded for the price bid.

FSA Contract Number FSA25-VEH23.0: Heavy Trucks and Buses

Bidder Company Name Broyhill Equipment LLC

Business Address One North Market Square PO Box 475
Dakota City NE 68731

Name of Authorized Agent Tammy Steemken

Email address of authorized agent accounting@broyhill.com

Signature DocuSigned by:
Tammy Steemken
1E71F74C01D940B...

Date 9/25/2025

FSA Contract Number

FSA25-VEH23.0: Heavy Trucks and Buses

Bidder Company Name Broyhill Equipment LLC



CONTRACT SIGNATURE FORM

By submitting a response to this Invitation to Bid and signing this form, the Bidder declares that he or she has read, and the company understands, accepts and will comply with the terms, conditions and specifications of this bid and any addenda issued. The failure or omission to review this document shall in no way relieve the authorized agent of obligations with respect to this bid. The submission of a bid and signature below shall be taken as evidence of acceptance of the terms and conditions of this bid.

The Bidder further declares that no other persons other than the authorized agent herein named has any interest in this bid or in the contract to be taken, and that it is made without any connection with any other person or persons making proposal for the same article, and is in all respects fair and without collusion or fraud.

The Bidder further declares that they have carefully examined the specifications and is thoroughly familiar with its provisions and with the quality, type and grade of materials required.

The Bidder further declares that they have provided a discount on all factory options included in this bid, and such discount will be included in all purchase orders.

The Bidder further declares that the company understands the financial responsibility associated with this bid as stated and further declares that it has the ability to meet the financial responsibility associated with this bid.

The Bidder further declares that the company will furnish the items awarded for the price bid.

FSA Contract Number FSA25-VEH23.0: Heavy Trucks and Buses

Bidder Company Name Container Systems & Equipment Co., Inc.

Business Address 506 Bellevue Av.
Daytona Beach, FL 32114

Name of Authorized Agent William Young

Email address of authorized agent byoung@containersys.com

Signed by:
Signature *William Young*
55E2D5B724E54AD...

Date 9/25/2025

FSA Contract Number

FSA25-VEH23.0: Heavy Trucks and Buses

Bidder Company Name Container Systems & Equipment Co., Inc.



CONTRACT SIGNATURE FORM

By submitting a response to this Invitation to Bid and signing this form, the Bidder declares that he or she has read, and the company understands, accepts and will comply with the terms, conditions and specifications of this bid and any addenda issued. The failure or omission to review this document shall in no way relieve the authorized agent of obligations with respect to this bid. The submission of a bid and signature below shall be taken as evidence of acceptance of the terms and conditions of this bid.

The Bidder further declares that no other persons other than the authorized agent herein named has any interest in this bid or in the contract to be taken, and that it is made without any connection with any other person or persons making proposal for the same article, and is in all respects fair and without collusion or fraud.

The Bidder further declares that they have carefully examined the specifications and is thoroughly familiar with its provisions and with the quality, type and grade of materials required.

The Bidder further declares that they have provided a discount on all factory options included in this bid, and such discount will be included in all purchase orders.

The Bidder further declares that the company understands the financial responsibility associated with this bid as stated and further declares that it has the ability to meet the financial responsibility associated with this bid.

The Bidder further declares that the company will furnish the items awarded for the price bid.

FSA Contract Number FSA25-VEH23.0: Heavy Trucks and Buses

Bidder Company Name Cumberland International trucks of Florida LLC

Business Address 2110 S Division Ave, Orlando, FL 32805

Name of Authorized Agent Erick Creasey

Email address of authorized agent ecreasey@cltte.com

Signed by:
Signature 
DD0E592BC03848C...

Date 9/30/2025

FSA Contract Number

FSA25-VEH23.0: Heavy Trucks and Buses

Bidder Company Name Cumberland International trucks of Florida LLC



CONTRACT SIGNATURE FORM

By submitting a response to this Invitation to Bid and signing this form, the Bidder declares that he or she has read, and the company understands, accepts and will comply with the terms, conditions and specifications of this bid and any addenda issued. The failure or omission to review this document shall in no way relieve the authorized agent of obligations with respect to this bid. The submission of a bid and signature below shall be taken as evidence of acceptance of the terms and conditions of this bid.

The Bidder further declares that no other persons other than the authorized agent herein named has any interest in this bid or in the contract to be taken, and that it is made without any connection with any other person or persons making proposal for the same article, and is in all respects fair and without collusion or fraud.

The Bidder further declares that they have carefully examined the specifications and is thoroughly familiar with its provisions and with the quality, type and grade of materials required.

The Bidder further declares that they have provided a discount on all factory options included in this bid, and such discount will be included in all purchase orders.

The Bidder further declares that the company understands the financial responsibility associated with this bid as stated and further declares that it has the ability to meet the financial responsibility associated with this bid.

The Bidder further declares that the company will furnish the items awarded for the price bid.

FSA Contract Number FSA25-VEH23.0: Heavy Trucks and Buses

Bidder Company Name DeLand Truck Center, inc.

Business Address 1208 South Woodland Blvd
DeLand Florida, 32720

Name of Authorized Agent Howard Williams

Email address of authorized agent howardwilliams@cfl.rr.com

Signed by:
Signature *Howard Williams*
A538AF2AA03F479...

Date 9/29/2025

FSA Contract Number

FSA25-VEH23.0: Heavy Trucks and Buses

Bidder Company Name DeLand Truck Center, inc.



CONTRACT SIGNATURE FORM

By submitting a response to this Invitation to Bid and signing this form, the Bidder declares that he or she has read, and the company understands, accepts and will comply with the terms, conditions and specifications of this bid and any addenda issued. The failure or omission to review this document shall in no way relieve the authorized agent of obligations with respect to this bid. The submission of a bid and signature below shall be taken as evidence of acceptance of the terms and conditions of this bid.

The Bidder further declares that no other persons other than the authorized agent herein named has any interest in this bid or in the contract to be taken, and that it is made without any connection with any other person or persons making proposal for the same article, and is in all respects fair and without collusion or fraud.

The Bidder further declares that they have carefully examined the specifications and is thoroughly familiar with its provisions and with the quality, type and grade of materials required.

The Bidder further declares that they have provided a discount on all factory options included in this bid, and such discount will be included in all purchase orders.

The Bidder further declares that the company understands the financial responsibility associated with this bid as stated and further declares that it has the ability to meet the financial responsibility associated with this bid.

The Bidder further declares that the company will furnish the items awarded for the price bid.

FSA Contract Number FSA25-VEH23.0: Heavy Trucks and Buses

Bidder Company Name Duval Ford Ilc

Business Address 405 Lane Ave North; Jacksonville, FL 32254

Name of Authorized Agent Richard Tackett

Email address of authorized agent RICHARD.TACKETT@DUVALFORD.COM

Signature DocuSigned by:
Richard Tackett
F167A39DD605483...

Date 9/25/2025

FSA Contract Number

FSA25-VEH23.0: Heavy Trucks and Buses

Bidder Company Name Duval Ford Ilc



CONTRACT SIGNATURE FORM

By submitting a response to this Invitation to Bid and signing this form, the Bidder declares that he or she has read, and the company understands, accepts and will comply with the terms, conditions and specifications of this bid and any addenda issued. The failure or omission to review this document shall in no way relieve the authorized agent of obligations with respect to this bid. The submission of a bid and signature below shall be taken as evidence of acceptance of the terms and conditions of this bid.

The Bidder further declares that no other persons other than the authorized agent herein named has any interest in this bid or in the contract to be taken, and that it is made without any connection with any other person or persons making proposal for the same article, and is in all respects fair and without collusion or fraud.

The Bidder further declares that they have carefully examined the specifications and is thoroughly familiar with its provisions and with the quality, type and grade of materials required.

The Bidder further declares that they have provided a discount on all factory options included in this bid, and such discount will be included in all purchase orders.

The Bidder further declares that the company understands the financial responsibility associated with this bid as stated and further declares that it has the ability to meet the financial responsibility associated with this bid.

The Bidder further declares that the company will furnish the items awarded for the price bid.

FSA Contract Number FSA25-VEH23.0: Heavy Trucks and Buses

Bidder Company Name Florida Kenworth, LLC

Business Address 1800 N. Orange Blossom Trail
Orlando, FL 32804

Name of Authorized Agent Ryan Van Wolvelaere

Email address of authorized agent ryan.vanwolvelaere@csctruck.com

Signed by:
Signature 
36C08D507A9C445...

Date 9/26/2025

FSA Contract Number

FSA25-VEH23.0: Heavy Trucks and Buses

Bidder Company Name Florida Kenworth, LLC



CONTRACT SIGNATURE FORM

By submitting a response to this Invitation to Bid and signing this form, the Bidder declares that he or she has read, and the company understands, accepts and will comply with the terms, conditions and specifications of this bid and any addenda issued. The failure or omission to review this document shall in no way relieve the authorized agent of obligations with respect to this bid. The submission of a bid and signature below shall be taken as evidence of acceptance of the terms and conditions of this bid.

The Bidder further declares that no other persons other than the authorized agent herein named has any interest in this bid or in the contract to be taken, and that it is made without any connection with any other person or persons making proposal for the same article, and is in all respects fair and without collusion or fraud.

The Bidder further declares that they have carefully examined the specifications and is thoroughly familiar with its provisions and with the quality, type and grade of materials required.

The Bidder further declares that they have provided a discount on all factory options included in this bid, and such discount will be included in all purchase orders.

The Bidder further declares that the company understands the financial responsibility associated with this bid as stated and further declares that it has the ability to meet the financial responsibility associated with this bid.

The Bidder further declares that the company will furnish the items awarded for the price bid.

FSA Contract Number FSA25-VEH23.0: Heavy Trucks and Buses

Bidder Company Name Florida Transportation Systems

Business Address 6041 Orient Road Tampa, FL 33610

Name of Authorized Agent Robert Frick

Email address of authorized agent rfrick@fts4buses.com

DocuSigned by:
Signature *Robert Frick*
027BAE08445744C...

Date 9/25/2025

FSA Contract Number

FSA25-VEH23.0: Heavy Trucks and Buses

Bidder Company Name Florida Transportation Systems



CONTRACT SIGNATURE FORM

By submitting a response to this Invitation to Bid and signing this form, the Bidder declares that he or she has read, and the company understands, accepts and will comply with the terms, conditions and specifications of this bid and any addenda issued. The failure or omission to review this document shall in no way relieve the authorized agent of obligations with respect to this bid. The submission of a bid and signature below shall be taken as evidence of acceptance of the terms and conditions of this bid.

The Bidder further declares that no other persons other than the authorized agent herein named has any interest in this bid or in the contract to be taken, and that it is made without any connection with any other person or persons making proposal for the same article, and is in all respects fair and without collusion or fraud.

The Bidder further declares that they have carefully examined the specifications and is thoroughly familiar with its provisions and with the quality, type and grade of materials required.

The Bidder further declares that they have provided a discount on all factory options included in this bid, and such discount will be included in all purchase orders.

The Bidder further declares that the company understands the financial responsibility associated with this bid as stated and further declares that it has the ability to meet the financial responsibility associated with this bid.

The Bidder further declares that the company will furnish the items awarded for the price bid.

FSA Contract Number FSA25-VEH23.0: Heavy Trucks and Buses

Bidder Company Name Kenworth of Jacksonville

Business Address 1121 Suemac Rd
Jacksonville, FL 32254

Name of Authorized Agent Ed Costello

Email address of authorized agent edcostello@kwjax.com

Signed by:
Signature 
8843C7BDF08B4DE...

Date 9/25/2025

FSA Contract Number

FSA25-VEH23.0: Heavy Trucks and Buses

Bidder Company Name Kenworth of Jacksonville



CONTRACT SIGNATURE FORM

By submitting a response to this Invitation to Bid and signing this form, the Bidder declares that he or she has read, and the company understands, accepts and will comply with the terms, conditions and specifications of this bid and any addenda issued. The failure or omission to review this document shall in no way relieve the authorized agent of obligations with respect to this bid. The submission of a bid and signature below shall be taken as evidence of acceptance of the terms and conditions of this bid.

The Bidder further declares that no other persons other than the authorized agent herein named has any interest in this bid or in the contract to be taken, and that it is made without any connection with any other person or persons making proposal for the same article, and is in all respects fair and without collusion or fraud.

The Bidder further declares that they have carefully examined the specifications and is thoroughly familiar with its provisions and with the quality, type and grade of materials required.

The Bidder further declares that they have provided a discount on all factory options included in this bid, and such discount will be included in all purchase orders.

The Bidder further declares that the company understands the financial responsibility associated with this bid as stated and further declares that it has the ability to meet the financial responsibility associated with this bid.

The Bidder further declares that the company will furnish the items awarded for the price bid.

FSA Contract Number FSA25-VEH23.0: Heavy Trucks and Buses

Bidder Company Name Matthews Bus Alliance, Inc.

Business Address 4802 W. Colonial Drive
Orlando, FL 32808

Name of Authorized Agent Lori Matthews

Email address of authorized agent bids@matthewsbusesflorida.com

Signed by:
Signature *Lori Matthews*
D8B27CB3FE9041A...

Date 9/25/2025

FSA Contract Number

FSA25-VEH23.0: Heavy Trucks and Buses

Bidder Company Name Matthews Bus Alliance, Inc.



CONTRACT SIGNATURE FORM

By submitting a response to this Invitation to Bid and signing this form, the Bidder declares that he or she has read, and the company understands, accepts and will comply with the terms, conditions and specifications of this bid and any addenda issued. The failure or omission to review this document shall in no way relieve the authorized agent of obligations with respect to this bid. The submission of a bid and signature below shall be taken as evidence of acceptance of the terms and conditions of this bid.

The Bidder further declares that no other persons other than the authorized agent herein named has any interest in this bid or in the contract to be taken, and that it is made without any connection with any other person or persons making proposal for the same article, and is in all respects fair and without collusion or fraud.

The Bidder further declares that they have carefully examined the specifications and is thoroughly familiar with its provisions and with the quality, type and grade of materials required.

The Bidder further declares that they have provided a discount on all factory options included in this bid, and such discount will be included in all purchase orders.

The Bidder further declares that the company understands the financial responsibility associated with this bid as stated and further declares that it has the ability to meet the financial responsibility associated with this bid.

The Bidder further declares that the company will furnish the items awarded for the price bid.

FSA Contract Number FSA25-VEH23.0: Heavy Trucks and Buses

Bidder Company Name Model 1 Commercial Vehicles, Inc.

Business Address 9225 Priority Way W Dr, Suite 300
Indianapolis, IN 46240

Name of Authorized Agent Jason Spore

Email address of authorized agent biddepartment@creativebussales.com

Signed by:
Signature *Jason Spore*
8DC5A6ED5A194FC...

Date 9/29/2025

FSA Contract Number

FSA25-VEH23.0: Heavy Trucks and Buses

Bidder Company Name Model 1 Commercial Vehicles, Inc.



CONTRACT SIGNATURE FORM

By submitting a response to this Invitation to Bid and signing this form, the Bidder declares that he or she has read, and the company understands, accepts and will comply with the terms, conditions and specifications of this bid and any addenda issued. The failure or omission to review this document shall in no way relieve the authorized agent of obligations with respect to this bid. The submission of a bid and signature below shall be taken as evidence of acceptance of the terms and conditions of this bid.

The Bidder further declares that no other persons other than the authorized agent herein named has any interest in this bid or in the contract to be taken, and that it is made without any connection with any other person or persons making proposal for the same article, and is in all respects fair and without collusion or fraud.

The Bidder further declares that they have carefully examined the specifications and is thoroughly familiar with its provisions and with the quality, type and grade of materials required.

The Bidder further declares that they have provided a discount on all factory options included in this bid, and such discount will be included in all purchase orders.

The Bidder further declares that the company understands the financial responsibility associated with this bid as stated and further declares that it has the ability to meet the financial responsibility associated with this bid.

The Bidder further declares that the company will furnish the items awarded for the price bid.

FSA Contract Number FSA25-VEH23.0: Heavy Trucks and Buses

Bidder Company Name Nextran Truck Centers

Business Address 1986 West Beaver Street, Jacksonville, FL 32209

Name of Authorized Agent Anthony Abatecola

Email address of authorized agent aabatecola@nexttranusa.com

Signed by:
Signature *Anthony Abatecola*
161F88AF22474AB...

Date 9/25/2025

FSA Contract Number

FSA25-VEH23.0: Heavy Trucks and Buses

Bidder Company Name Nextran Truck Centers



CONTRACT SIGNATURE FORM

By submitting a response to this Invitation to Bid and signing this form, the Bidder declares that he or she has read, and the company understands, accepts and will comply with the terms, conditions and specifications of this bid and any addenda issued. The failure or omission to review this document shall in no way relieve the authorized agent of obligations with respect to this bid. The submission of a bid and signature below shall be taken as evidence of acceptance of the terms and conditions of this bid.

The Bidder further declares that no other persons other than the authorized agent herein named has any interest in this bid or in the contract to be taken, and that it is made without any connection with any other person or persons making proposal for the same article, and is in all respects fair and without collusion or fraud.

The Bidder further declares that they have carefully examined the specifications and is thoroughly familiar with its provisions and with the quality, type and grade of materials required.

The Bidder further declares that they have provided a discount on all factory options included in this bid, and such discount will be included in all purchase orders.

The Bidder further declares that the company understands the financial responsibility associated with this bid as stated and further declares that it has the ability to meet the financial responsibility associated with this bid.

The Bidder further declares that the company will furnish the items awarded for the price bid.

FSA Contract Number FSA25-VEH23.0: Heavy Trucks and Buses

Bidder Company Name Orlando Freightliner

Business Address 2455 So. Orange Blossom Trail
Apopka Fl., 32703

Name of Authorized Agent Bob Scharpnick

Email address of authorized agent bscharpnick@orlandofreightliner.com

Signed by:
Signature *Bob Scharpnick*
927292C6461D433...

Date 9/25/2025

FSA Contract Number

FSA25-VEH23.0: Heavy Trucks and Buses

Bidder Company Name Orlando Freightliner



CONTRACT SIGNATURE FORM

By submitting a response to this Invitation to Bid and signing this form, the Bidder declares that he or she has read, and the company understands, accepts and will comply with the terms, conditions and specifications of this bid and any addenda issued. The failure or omission to review this document shall in no way relieve the authorized agent of obligations with respect to this bid. The submission of a bid and signature below shall be taken as evidence of acceptance of the terms and conditions of this bid.

The Bidder further declares that no other persons other than the authorized agent herein named has any interest in this bid or in the contract to be taken, and that it is made without any connection with any other person or persons making proposal for the same article, and is in all respects fair and without collusion or fraud.

The Bidder further declares that they have carefully examined the specifications and is thoroughly familiar with its provisions and with the quality, type and grade of materials required.

The Bidder further declares that they have provided a discount on all factory options included in this bid, and such discount will be included in all purchase orders.

The Bidder further declares that the company understands the financial responsibility associated with this bid as stated and further declares that it has the ability to meet the financial responsibility associated with this bid.

The Bidder further declares that the company will furnish the items awarded for the price bid.

FSA Contract Number FSA25-VEH23.0: Heavy Trucks and Buses

Bidder Company Name Ottawa Trucks Center Inc.

Business Address 7227 NW 74th Ave Miami, FL 33166

Name of Authorized Agent Peter Albanese

Email address of authorized agent palbanese@rechtien.com

Signed by:
Signature 
F3DE28A8522146A...

Date 9/25/2025

FSA Contract Number

FSA25-VEH23.0: Heavy Trucks and Buses

Bidder Company Name Ottawa Trucks Center Inc.



CONTRACT SIGNATURE FORM

By submitting a response to this Invitation to Bid and signing this form, the Bidder declares that he or she has read, and the company understands, accepts and will comply with the terms, conditions and specifications of this bid and any addenda issued. The failure or omission to review this document shall in no way relieve the authorized agent of obligations with respect to this bid. The submission of a bid and signature below shall be taken as evidence of acceptance of the terms and conditions of this bid.

The Bidder further declares that no other persons other than the authorized agent herein named has any interest in this bid or in the contract to be taken, and that it is made without any connection with any other person or persons making proposal for the same article, and is in all respects fair and without collusion or fraud.

The Bidder further declares that they have carefully examined the specifications and is thoroughly familiar with its provisions and with the quality, type and grade of materials required.

The Bidder further declares that they have provided a discount on all factory options included in this bid, and such discount will be included in all purchase orders.

The Bidder further declares that the company understands the financial responsibility associated with this bid as stated and further declares that it has the ability to meet the financial responsibility associated with this bid.

The Bidder further declares that the company will furnish the items awarded for the price bid.

FSA Contract Number FSA25-VEH23.0: Heavy Trucks and Buses

Bidder Company Name The Peterbilt Store South Florida LLC

Business Address 2441 S. State Rd. 7
Ft. Lauderdale, Fl. 33317

Name of Authorized Agent Andy Hallums

Email address of authorized agent ahallums@thepetestore.com

Signed by:
Signature 
E30E7B0B833F4F7...

Date 9/25/2025

FSA Contract Number

FSA25-VEH23.0: Heavy Trucks and Buses

Bidder Company Name The Peterbilt Store South Florida LLC



CONTRACT SIGNATURE FORM

By submitting a response to this Invitation to Bid and signing this form, the Bidder declares that he or she has read, and the company understands, accepts and will comply with the terms, conditions and specifications of this bid and any addenda issued. The failure or omission to review this document shall in no way relieve the authorized agent of obligations with respect to this bid. The submission of a bid and signature below shall be taken as evidence of acceptance of the terms and conditions of this bid.

The Bidder further declares that no other persons other than the authorized agent herein named has any interest in this bid or in the contract to be taken, and that it is made without any connection with any other person or persons making proposal for the same article, and is in all respects fair and without collusion or fraud.

The Bidder further declares that they have carefully examined the specifications and is thoroughly familiar with its provisions and with the quality, type and grade of materials required.

The Bidder further declares that they have provided a discount on all factory options included in this bid, and such discount will be included in all purchase orders.

The Bidder further declares that the company understands the financial responsibility associated with this bid as stated and further declares that it has the ability to meet the financial responsibility associated with this bid.

The Bidder further declares that the company will furnish the items awarded for the price bid.

FSA Contract Number FSA25-VEH23.0: Heavy Trucks and Buses

Bidder Company Name RDK Assets Inc

Business Address 3214 E Adamo Dr
Tampa, FL 33605

Name of Authorized Agent Richard Kemner

Email address of authorized agent craigchown@gmail.com

Signed by:
Signature *Richard Kemner*
DC78FC7049394D7...

Date 9/28/2025

FSA Contract Number

FSA25-VEH23.0: Heavy Trucks and Buses

Bidder Company Name RDK Assets Inc



CONTRACT SIGNATURE FORM

By submitting a response to this Invitation to Bid and signing this form, the Bidder declares that he or she has read, and the company understands, accepts and will comply with the terms, conditions and specifications of this bid and any addenda issued. The failure or omission to review this document shall in no way relieve the authorized agent of obligations with respect to this bid. The submission of a bid and signature below shall be taken as evidence of acceptance of the terms and conditions of this bid.

The Bidder further declares that no other persons other than the authorized agent herein named has any interest in this bid or in the contract to be taken, and that it is made without any connection with any other person or persons making proposal for the same article, and is in all respects fair and without collusion or fraud.

The Bidder further declares that they have carefully examined the specifications and is thoroughly familiar with its provisions and with the quality, type and grade of materials required.

The Bidder further declares that they have provided a discount on all factory options included in this bid, and such discount will be included in all purchase orders.

The Bidder further declares that the company understands the financial responsibility associated with this bid as stated and further declares that it has the ability to meet the financial responsibility associated with this bid.

The Bidder further declares that the company will furnish the items awarded for the price bid.

FSA Contract Number FSA25-VEH23.0: Heavy Trucks and Buses

Bidder Company Name RECHTIEN INTERNATIONAL TRUCKS

Business Address 7227 NW 74th Ave., Miami, FL 33166

Name of Authorized Agent CARLOS CORREA

Email address of authorized agent ccorrea@rechtien.com

Signed by:
Signature 
594602F83AF74C1...

Date 9/25/2025

FSA Contract Number

FSA25-VEH23.0: Heavy Trucks and Buses

Bidder Company Name RECHTIEN INTERNATIONAL TRUCKS



CONTRACT SIGNATURE FORM

By submitting a response to this Invitation to Bid and signing this form, the Bidder declares that he or she has read, and the company understands, accepts and will comply with the terms, conditions and specifications of this bid and any addenda issued. The failure or omission to review this document shall in no way relieve the authorized agent of obligations with respect to this bid. The submission of a bid and signature below shall be taken as evidence of acceptance of the terms and conditions of this bid.

The Bidder further declares that no other persons other than the authorized agent herein named has any interest in this bid or in the contract to be taken, and that it is made without any connection with any other person or persons making proposal for the same article, and is in all respects fair and without collusion or fraud.

The Bidder further declares that they have carefully examined the specifications and is thoroughly familiar with its provisions and with the quality, type and grade of materials required.

The Bidder further declares that they have provided a discount on all factory options included in this bid, and such discount will be included in all purchase orders.

The Bidder further declares that the company understands the financial responsibility associated with this bid as stated and further declares that it has the ability to meet the financial responsibility associated with this bid.

The Bidder further declares that the company will furnish the items awarded for the price bid.

FSA Contract Number FSA25-VEH23.0: Heavy Trucks and Buses

Bidder Company Name Rush Truck Centers of Florida

Business Address 8111 E Adamo Dr. Tampa, FL 33619

Name of Authorized Agent Paul Canadine

Email address of authorized agent canadinep@rushenterprises.com

Signature DocuSigned by:
Paul Canadine
CD8E6988C97C4C1...

Date 9/25/2025

FSA Contract Number

FSA25-VEH23.0: Heavy Trucks and Buses

Bidder Company Name Rush Truck Centers of Florida



CONTRACT SIGNATURE FORM

By submitting a response to this Invitation to Bid and signing this form, the Bidder declares that he or she has read, and the company understands, accepts and will comply with the terms, conditions and specifications of this bid and any addenda issued. The failure or omission to review this document shall in no way relieve the authorized agent of obligations with respect to this bid. The submission of a bid and signature below shall be taken as evidence of acceptance of the terms and conditions of this bid.

The Bidder further declares that no other persons other than the authorized agent herein named has any interest in this bid or in the contract to be taken, and that it is made without any connection with any other person or persons making proposal for the same article, and is in all respects fair and without collusion or fraud.

The Bidder further declares that they have carefully examined the specifications and is thoroughly familiar with its provisions and with the quality, type and grade of materials required.

The Bidder further declares that they have provided a discount on all factory options included in this bid, and such discount will be included in all purchase orders.

The Bidder further declares that the company understands the financial responsibility associated with this bid as stated and further declares that it has the ability to meet the financial responsibility associated with this bid.

The Bidder further declares that the company will furnish the items awarded for the price bid.

FSA Contract Number FSA25-VEH23.0: Heavy Trucks and Buses

Bidder Company Name SBL Freightliner LLC

Business Address 2840 Center Port Circle Pompano Beach FL 33064

Name of Authorized Agent Don Maher

Email address of authorized agent dmaher@freightlinerfl.com

Signed by:
Signature *Don Maher*
85B56C3FDE584D2...

Date 9/25/2025

FSA Contract Number

FSA25-VEH23.0: Heavy Trucks and Buses

Bidder Company Name SBL Freightliner LLC



CONTRACT SIGNATURE FORM

By submitting a response to this Invitation to Bid and signing this form, the Bidder declares that he or she has read, and the company understands, accepts and will comply with the terms, conditions and specifications of this bid and any addenda issued. The failure or omission to review this document shall in no way relieve the authorized agent of obligations with respect to this bid. The submission of a bid and signature below shall be taken as evidence of acceptance of the terms and conditions of this bid.

The Bidder further declares that no other persons other than the authorized agent herein named has any interest in this bid or in the contract to be taken, and that it is made without any connection with any other person or persons making proposal for the same article, and is in all respects fair and without collusion or fraud.

The Bidder further declares that they have carefully examined the specifications and is thoroughly familiar with its provisions and with the quality, type and grade of materials required.

The Bidder further declares that they have provided a discount on all factory options included in this bid, and such discount will be included in all purchase orders.

The Bidder further declares that the company understands the financial responsibility associated with this bid as stated and further declares that it has the ability to meet the financial responsibility associated with this bid.

The Bidder further declares that the company will furnish the items awarded for the price bid.

FSA Contract Number FSA25-VEH23.0: Heavy Trucks and Buses

Bidder Company Name Sun State International Trucks, LLC

Business Address 6020 Adamo Dr., Tampa, FL, 33619

Name of Authorized Agent Dave Metcalf

Email address of authorized agent dave.metcalf@sunstateintl.com

DocuSigned by:
Signature *Dave Metcalf*
2F23AD89B486452...

Date 9/28/2025

FSA Contract Number

FSA25-VEH23.0: Heavy Trucks and Buses

Bidder Company Name Sun State International Trucks, LLC



CONTRACT SIGNATURE FORM

By submitting a response to this Invitation to Bid and signing this form, the Bidder declares that he or she has read, and the company understands, accepts and will comply with the terms, conditions and specifications of this bid and any addenda issued. The failure or omission to review this document shall in no way relieve the authorized agent of obligations with respect to this bid. The submission of a bid and signature below shall be taken as evidence of acceptance of the terms and conditions of this bid.

The Bidder further declares that no other persons other than the authorized agent herein named has any interest in this bid or in the contract to be taken, and that it is made without any connection with any other person or persons making proposal for the same article, and is in all respects fair and without collusion or fraud.

The Bidder further declares that they have carefully examined the specifications and is thoroughly familiar with its provisions and with the quality, type and grade of materials required.

The Bidder further declares that they have provided a discount on all factory options included in this bid, and such discount will be included in all purchase orders.

The Bidder further declares that the company understands the financial responsibility associated with this bid as stated and further declares that it has the ability to meet the financial responsibility associated with this bid.

The Bidder further declares that the company will furnish the items awarded for the price bid.

FSA Contract Number FSA25-VEH23.0: Heavy Trucks and Buses

Bidder Company Name Tampa Truck Center LLC

Business Address 7528 US HWY 301N, Tampa, FL 33637

Name of Authorized Agent Scott Endris

Email address of authorized agent sendris@southporttruck.com

Signature 

Date 9/25/2025

FSA Contract Number

FSA25-VEH23.0: Heavy Trucks and Buses

Bidder Company Name Tampa Truck Center LLC



CONTRACT SIGNATURE FORM

By submitting a response to this Invitation to Bid and signing this form, the Bidder declares that he or she has read, and the company understands, accepts and will comply with the terms, conditions and specifications of this bid and any addenda issued. The failure or omission to review this document shall in no way relieve the authorized agent of obligations with respect to this bid. The submission of a bid and signature below shall be taken as evidence of acceptance of the terms and conditions of this bid.

The Bidder further declares that no other persons other than the authorized agent herein named has any interest in this bid or in the contract to be taken, and that it is made without any connection with any other person or persons making proposal for the same article, and is in all respects fair and without collusion or fraud.

The Bidder further declares that they have carefully examined the specifications and is thoroughly familiar with its provisions and with the quality, type and grade of materials required.

The Bidder further declares that they have provided a discount on all factory options included in this bid, and such discount will be included in all purchase orders.

The Bidder further declares that the company understands the financial responsibility associated with this bid as stated and further declares that it has the ability to meet the financial responsibility associated with this bid.

The Bidder further declares that the company will furnish the items awarded for the price bid.

FSA Contract Number FSA25-VEH23.0: Heavy Trucks and Buses

Bidder Company Name Terradyne Armored Vehicles Inc.

Business Address 1-402 Mulock Drive, Newmarket, Ontario, L3Y 9B8

Name of Authorized Agent Lucas Witzke

Email address of authorized agent lucus.witzke@terradyneinc.com

DocuSigned by:
Signature *Lucas Witzke*
045391049B324AD...

Date 9/25/2025

FSA Contract Number

FSA25-VEH23.0: Heavy Trucks and Buses

Bidder Company Name Terradyne Armored Vehicles Inc.



CONTRACT SIGNATURE FORM

By submitting a response to this Invitation to Bid and signing this form, the Bidder declares that he or she has read, and the company understands, accepts and will comply with the terms, conditions and specifications of this bid and any addenda issued. The failure or omission to review this document shall in no way relieve the authorized agent of obligations with respect to this bid. The submission of a bid and signature below shall be taken as evidence of acceptance of the terms and conditions of this bid.

The Bidder further declares that no other persons other than the authorized agent herein named has any interest in this bid or in the contract to be taken, and that it is made without any connection with any other person or persons making proposal for the same article, and is in all respects fair and without collusion or fraud.

The Bidder further declares that they have carefully examined the specifications and is thoroughly familiar with its provisions and with the quality, type and grade of materials required.

The Bidder further declares that they have provided a discount on all factory options included in this bid, and such discount will be included in all purchase orders.

The Bidder further declares that the company understands the financial responsibility associated with this bid as stated and further declares that it has the ability to meet the financial responsibility associated with this bid.

The Bidder further declares that the company will furnish the items awarded for the price bid.

FSA Contract Number FSA25-VEH23.0: Heavy Trucks and Buses

Bidder Company Name Truckmax, inc.

Business Address 6000 NW 77TH COURT, MIAMI, FLORIDA, 33166

Name of Authorized Agent Gil Chez

Email address of authorized agent GCHEZ@TRUCKMAX.COM

Signed by:
Signature 
FBD79737C2A8444...

Date 9/25/2025

FSA Contract Number

FSA25-VEH23.0: Heavy Trucks and Buses

Bidder Company Name Truckmax, inc.

FSA Cooperative Purchasing Program



**FSA25-VEH23.0: Heavy Trucks and Buses
Final Award Report**

Bid Award

Contract: FSA25-VEH23.0, Heavy Trucks and Buses

Group: Buses Electric: 19 to 20 Passenger Capacity Range, Van-Type Cutaway Chassis

Item: 1, BYD/RIDE, The Achiever, The Achiever

Description: Refer FSA Base Specifications PDF document.

Model Upgrade/Downgrade:

Zone	Rank	Vendor	Price	Build File	Options File
Western	Primary	Model 1 Commercial Vehicles, Inc.	\$310,896.00	Build	Options
Northern	Primary	Model 1 Commercial Vehicles, Inc.	\$310,896.00	Build	Options
Central	Primary	Model 1 Commercial Vehicles, Inc.	\$310,896.00	Build	Options
Southern	Primary	Model 1 Commercial Vehicles, Inc.	\$310,896.00	Build	Options

Bid Award

Contract: FSA25-VEH23.0, Heavy Trucks and Buses

Group: Buses Electric: 19 to 20 Passenger Capacity Range, Van-Type Cutaway Chassis

Item: 2, Endera, B-Series, B-Series

Description: Refer FSA Base Specifications PDF document.

Model Upgrade/Downgrade:

Zone	Rank	Vendor	Price	Build File	Options File
Western	Primary	Florida Transportation Systems, Inc.	\$321,639.00	Build	Options
Northern	Primary	Florida Transportation Systems, Inc.	\$321,639.00	Build	Options
Central	Primary	Florida Transportation Systems, Inc.	\$321,639.00	Build	Options
Southern	Primary	Florida Transportation Systems, Inc.	\$321,639.00	Build	Options

Bid Award

Contract: FSA25-VEH23.0, Heavy Trucks and Buses

Group: Buses Electric: 20 to 52 Passenger Capacity Range, Conventional-Type Chassis

Item: 3, Bluebird, All-American Electric, T3RE

Description: Refer FSA Base Specifications PDF document.

Model Upgrade/Downgrade:

Zone	Rank	Vendor	Price	Build File	Options File
Western	Primary	Florida Transportation Systems, Inc.	\$430,321.00	Build	Options
Northern	Primary	Florida Transportation Systems, Inc.	\$430,321.00	Build	Options
Central	Primary	Florida Transportation Systems, Inc.	\$430,321.00	Build	Options
Southern	Primary	Florida Transportation Systems, Inc.	\$430,321.00	Build	Options

Bid Award

Contract: FSA25-VEH23.0, Heavy Trucks and Buses

Group: Buses Electric: 20 to 52 Passenger Capacity Range, Conventional-Type Chassis

Item: 4, Bluebird, Vision Electric, Vision Electric

Description: Refer FSA Base Specifications PDF document.

Model Upgrade/Downgrade:

Zone	Rank	Vendor	Price	Build File	Options File
Western	Primary	Florida Transportation Systems, Inc.	\$412,921.00	Build	Options
Northern	Primary	Florida Transportation Systems, Inc.	\$412,921.00	Build	Options
Central	Primary	Florida Transportation Systems, Inc.	\$412,921.00	Build	Options
Southern	Primary	Florida Transportation Systems, Inc.	\$412,921.00	Build	Options

Bid Award

Contract: FSA25-VEH23.0, Heavy Trucks and Buses

Group: Buses Electric: 20 to 52 Passenger Capacity Range, Conventional-Type Chassis

Item: 5, BYD/RIDE, The Creator, The Creator

Description: Refer FSA Base Specifications PDF document.

Model Upgrade/Downgrade:

Zone	Rank	Vendor	Price	Build File	Options File
Western	Primary	Model 1 Commercial Vehicles, Inc.	\$399,639.00	Build	Options
Northern	Primary	Model 1 Commercial Vehicles, Inc.	\$399,639.00	Build	Options
Central	Primary	Model 1 Commercial Vehicles, Inc.	\$399,639.00	Build	Options
Southern	Primary	Model 1 Commercial Vehicles, Inc.	\$399,639.00	Build	Options

Bid Award

Contract: FSA25-VEH23.0, Heavy Trucks and Buses

Group: Buses Electric: 44 To 80 Passenger Capacity Range, Commercial-Type Chassis

Item: 7, BYD/RIDE, The Dreamer, Type D Electric School Bus

Description: Refer FSA Base Specifications PDF document.

Model Upgrade/Downgrade:

Zone	Rank	Vendor	Price	Build File	Options File
Western	Primary	Model 1 Commercial Vehicles, Inc.	\$430,525.00	Build	Options
Northern	Primary	Model 1 Commercial Vehicles, Inc.	\$430,525.00	Build	Options
Central	Primary	Model 1 Commercial Vehicles, Inc.	\$430,525.00	Build	Options
Southern	Primary	Model 1 Commercial Vehicles, Inc.	\$430,525.00	Build	Options

Bid Award

Contract: FSA25-VEH23.0, Heavy Trucks and Buses

Group: Buses: 14 to 25 Passenger Capacity Range, Van-Type Cutaway Chassis

Item: 8, Endera, B-Series, B-Series

Description: Refer FSA Base Specifications PDF document.

Model Upgrade/Downgrade:

Zone	Rank	Vendor	Price	Build File	Options File
Western	Primary	Florida Transportation Systems, Inc.	\$119,274.00	Build	Options
Northern	Primary	Florida Transportation Systems, Inc.	\$119,174.00	Build	Options
Central	Primary	Florida Transportation Systems, Inc.	\$119,174.00	Build	Options
Southern	Primary	Florida Transportation Systems, Inc.	\$119,274.00	Build	Options

Bid Award

Contract: FSA25-VEH23.0, Heavy Trucks and Buses

Group: Buses: 14 to 25 Passenger Capacity Range, Van-Type Cutaway Chassis

Item: 10, Starcraft, Allstar, Allstar

Description: Refer FSA Base Specifications PDF document.

Model Upgrade/Downgrade:

Zone	Rank	Vendor	Price	Build File	Options File
Western	Primary	Model 1 Commercial Vehicles, Inc.	\$88,276.00	Build	Options
Northern	Primary	Model 1 Commercial Vehicles, Inc.	\$88,276.00	Build	Options
Central	Primary	Model 1 Commercial Vehicles, Inc.	\$88,276.00	Build	Options
Southern	Primary	Model 1 Commercial Vehicles, Inc.	\$88,276.00	Build	Options

Bid Award

Contract: FSA25-VEH23.0, Heavy Trucks and Buses

Group: Buses: 14 to 25 Passenger Capacity Range, Van-Type Cutaway Chassis

Item: 11, StarTrans, The Senator II, Senator SII 22

Description: Refer FSA Base Specifications PDF document.

Model Upgrade/Downgrade:

Zone	Rank	Vendor	Price	Build File	Options File
Western	Primary	Matthews Bus Alliance Inc.	\$102,962.00	Build	Options
Northern	Primary	Matthews Bus Alliance Inc.	\$102,962.00	Build	Options
Central	Primary	Matthews Bus Alliance Inc.	\$102,962.00	Build	Options
Southern	Primary	Matthews Bus Alliance Inc.	\$102,962.00	Build	Options

Bid Award

Contract: FSA25-VEH23.0, Heavy Trucks and Buses

Group: Buses: 20 to 52 Passenger Capacity Range, Conventional Truck-Type Cutaway Chassis

Item: 12, Bluebird, Vision, Vision

Description: Refer FSA Base Specifications PDF document.

Model Upgrade/Downgrade:

Zone	Rank	Vendor	Price	Build File	Options File
Western	Primary	Florida Transportation Systems, Inc.	\$160,751.00	Build	Options
Northern	Primary	Florida Transportation Systems, Inc.	\$160,651.00	Build	Options
Central	Primary	Florida Transportation Systems, Inc.	\$160,651.00	Build	Options
Southern	Primary	Florida Transportation Systems, Inc.	\$160,751.00	Build	Options

Bid Award

Contract: FSA25-VEH23.0, Heavy Trucks and Buses

Group: Buses: 20 to 52 Passenger Capacity Range, Conventional Truck-Type Cutaway Chassis

Item: 13, Starcraft, Allstar, Allstar

Description: Refer FSA Base Specifications PDF document.

Model Upgrade/Downgrade:

Zone	Rank	Vendor	Price	Build File	Options File
Western	Primary	Model 1 Commercial Vehicles, Inc.	\$149,252.00	Build	Options
Northern	Primary	Model 1 Commercial Vehicles, Inc.	\$149,252.00	Build	Options
Central	Primary	Model 1 Commercial Vehicles, Inc.	\$149,252.00	Build	Options
Southern	Primary	Model 1 Commercial Vehicles, Inc.	\$149,252.00	Build	Options

Bid Award

Contract: FSA25-VEH23.0, Heavy Trucks and Buses

Group: Buses: 20 to 52 Passenger Capacity Range, Conventional Truck-Type Cutaway Chassis

Item: 14, StarTrans, The Senator II HD, Senator HD 28

Description: Refer FSA Base Specifications PDF document.

Model Upgrade/Downgrade:

Zone	Rank	Vendor	Price	Build File	Options File
Western	Primary	Matthews Bus Alliance Inc.	\$159,499.00	Build	Options
	Alternate	Duval Ford LLC	\$170,017.00	Build	Options
Northern	Primary	Matthews Bus Alliance Inc.	\$159,499.00	Build	Options
	Alternate	Duval Ford LLC	\$169,807.00	Build	Options
Central	Primary	Matthews Bus Alliance Inc.	\$159,499.00	Build	Options
	Alternate	Duval Ford LLC	\$170,017.00	Build	Options
Southern	Primary	Matthews Bus Alliance Inc.	\$159,499.00	Build	Options
	Alternate	Duval Ford LLC	\$170,042.00	Build	Options

Bid Award

Contract: FSA25-VEH23.0, Heavy Trucks and Buses

Group: Buses: 33 to 54 Passenger Capacity Range, Commercial-Type, Rear Engine Chassis

Item: 15, Bluebird, T3RE, T3RE

Description: Refer FSA Base Specifications PDF document.

Model Upgrade/Downgrade:

Zone	Rank	Vendor	Price	Build File	Options File
Western	Primary	Florida Transportation Systems, Inc.	\$192,676.00	Build	Options
Northern	Primary	Florida Transportation Systems, Inc.	\$192,576.00	Build	Options
Central	Primary	Florida Transportation Systems, Inc.	\$192,576.00	Build	Options
Southern	Primary	Florida Transportation Systems, Inc.	\$192,676.00	Build	Options

Bid Award**Contract:** FSA25-VEH23.0, Heavy Trucks and Buses**Group:** Buses: 36 to 52 Passenger Capacity Range, Commercial-Type, Front Engine Chassis**Item:** 16, Bluebird, T3FE, T3FE**Description:** Refer FSA Base Specifications PDF document.**Model Upgrade/Downgrade:**

Zone	Rank	Vendor	Price	Build File	Options File
Western	Primary	Florida Transportation Systems, Inc.	\$174,229.00	Build	Options
Northern	Primary	Florida Transportation Systems, Inc.	\$174,129.00	Build	Options
Central	Primary	Florida Transportation Systems, Inc.	\$174,129.00	Build	Options
Southern	Primary	Florida Transportation Systems, Inc.	\$174,229.00	Build	Options

Bid Award

Contract: FSA25-VEH23.0, Heavy Trucks and Buses

Group: Cab and Chassis Trucks Electric: 54,000 lbs. GVWR 4x6 Semi Tractor

Item: 17, Kenworth, T680E, T680E

Description: Refer FSA Base Specifications PDF document.

Model Upgrade/Downgrade:

Zone	Rank	Vendor	Price	Build File	Options File
Western					
Northern	Primary	Kenworth of Jacksonville	\$346,360.00	Build	Options
Central	Primary	All Roads Kenworth, LLC.	\$503,450.00	Build	Options
Southern	Primary	All Roads Kenworth, LLC.	\$503,450.00	Build	Options

Bid Award

Contract: FSA25-VEH23.0, Heavy Trucks and Buses

Group: Cab and Chassis Trucks Electric: 54,000 lbs. GVWR 4x6 Semi Tractor

Item: 18, Peterbilt, 579EV, 579EV

Description: Refer FSA Base Specifications PDF document.

Model Upgrade/Downgrade:

Zone	Rank	Vendor	Price	Build File	Options File
Western	Primary	Rush Truck Centers of Florida, Inc.	\$437,640.00	Build	Options
Northern	Primary	Rush Truck Centers of Florida, Inc.	\$437,640.00	Build	Options
Central	Primary	Rush Truck Centers of Florida, Inc.	\$437,640.00	Build	Options
Southern	Primary	The Peterbilt Store South Florida LLC	\$439,750.00	Build	Options

Bid Award

Contract: FSA25-VEH23.0, Heavy Trucks and Buses

Group: Cab and Chassis Trucks Electric: 54,000 lbs. GVWR 4x6 Semi Tractor

Item: 19, Volvo, VNR Electric, VNRe

Description: Refer FSA Base Specifications PDF document.

Model Upgrade/Downgrade:

Zone	Rank	Vendor	Price	Build File	Options File
Western	Primary	Nextran Truck Centers	\$387,681.00	Build	Options
Northern	Primary	Nextran Truck Centers	\$387,681.00	Build	Options
Central	Primary	Nextran Truck Centers	\$387,681.00	Build	Options
Southern	Primary	Nextran Truck Centers	\$387,681.00	Build	Options

Bid Award

Contract: FSA25-VEH23.0, Heavy Trucks and Buses

Group: Cab and Chassis Trucks Electric: Conventional Cab 33,000 lbs. GVWR (DRW) 4x2

Item: 20, International, EMV, MV60E

Description: Refer FSA Base Specifications PDF document.

Model Upgrade/Downgrade:

Zone	Rank	Vendor	Price	Build File	Options File
Western	Primary	Cumberland International Trucks of Florida	\$283,750.00	Build	Options
Northern	Primary	Cumberland International Trucks of Florida	\$283,000.00	Build	Options
Central	Primary	Cumberland International Trucks of Florida	\$283,000.00	Build	Options
	Alternate	Sun State International Trucks	\$283,820.00	Build	Options
Southern	Primary	Rechtien International Trucks	\$283,500.00	Build	Options

Bid Award

Contract: FSA25-VEH23.0, Heavy Trucks and Buses

Group: Cab and Chassis Trucks Electric: Conventional Cab 33,000 lbs. GVWR (DRW) 4x2

Item: 21, Mack, MD7 Electric, MDe7

Description: Refer FSA Base Specifications PDF document.

Model Upgrade/Downgrade:

Zone	Rank	Vendor	Price	Build File	Options File
Western	Primary	Nextran Truck Centers	\$248,990.00	Build	Options
Northern	Primary	Nextran Truck Centers	\$248,990.00	Build	Options
Central	Primary	Nextran Truck Centers	\$248,990.00	Build	Options
Southern	Primary	Nextran Truck Centers	\$248,990.00	Build	Options

Bid Award

Contract: FSA25-VEH23.0, Heavy Trucks and Buses

Group: Cab and Chassis Trucks Electric: Tilt Cab 26,000 lbs. GVWR (DRW) 4x2

Item: 22, Battle Motors, Striker EV, Striker EV

Description: Refer FSA Base Specifications PDF document.

Model Upgrade/Downgrade:

Zone	Rank	Vendor	Price	Build File	Options File
Western	Primary	Container Systems & Equipment Co., Inc.	\$431,600.00	Build	Options
Northern	Primary	Container Systems & Equipment Co., Inc.	\$431,600.00	Build	Options
Central	Primary	Container Systems & Equipment Co., Inc.	\$431,600.00	Build	Options
Southern	Primary	Container Systems & Equipment Co., Inc.	\$431,600.00	Build	Options

Bid Award

Contract: FSA25-VEH23.0, Heavy Trucks and Buses

Group: Cab and Chassis Trucks: 12,000 lbs. GVWR (DRW) 4x2 Tilt Cab

Item: 23, Isuzu, NPR-HD, N3F1

Description: Refer FSA Base Specifications PDF document.

Model Upgrade/Downgrade:

Zone	Rank	Vendor	Price	Build File	Options File
Western	Primary	DeLand Truck Center, Inc.	\$57,920.00	Build	Options
	Alternate	Nextran Truck Centers	\$62,770.00	Build	Options
Northern	Primary	DeLand Truck Center, Inc.	\$57,920.00	Build	Options
	Alternate	Nextran Truck Centers	\$62,770.00	Build	Options
Central	Primary	DeLand Truck Center, Inc.	\$57,920.00	Build	Options
	Alternate	Nextran Truck Centers	\$62,770.00	Build	Options
Southern	Primary	DeLand Truck Center, Inc.	\$57,920.00	Build	Options
	Alternate	Nextran Truck Centers	\$62,770.00	Build	Options

Bid Award**Contract:** FSA25-VEH23.0, Heavy Trucks and Buses**Group:** Cab and Chassis Trucks: 17,500 lbs. GVWR (DRW) 4x2**Item:** 24, Ford, F-550 Crew Cab, W5G**Description:** Refer FSA Base Specifications PDF document.**Model Upgrade/Downgrade:**

Zone	Rank	Vendor	Price	Build File	Options File
Western	Primary	BOZARD FORD	\$63,989.00	Build	Options
	Alternate	Duval Ford LLC	\$64,225.00	Build	Options
	Alternate	Bachrodt FT, LLC dba Palmetto Ford of Miami	\$64,232.00	Build	Options
Northern	Primary	Bachrodt FT, LLC dba Palmetto Ford of Miami	\$63,932.00	Build	Options
	Alternate	BOZARD FORD	\$63,989.00	Build	Options
	Alternate	Duval Ford LLC	\$64,015.00	Build	Options
Central	Primary	Bachrodt FT, LLC dba Palmetto Ford of Miami	\$63,832.00	Build	Options
	Alternate	BOZARD FORD	\$64,131.00	Build	Options
	Alternate	Duval Ford LLC	\$64,225.00	Build	Options
Southern	Primary	Bachrodt FT, LLC dba Palmetto Ford of Miami	\$63,832.00	Build	Options
	Alternate	BOZARD FORD	\$64,131.00	Build	Options
	Alternate	Duval Ford LLC	\$64,250.00	Build	Options

Bid Award

Contract: FSA25-VEH23.0, Heavy Trucks and Buses

Group: Cab and Chassis Trucks: 17,500 lbs. GVWR (DRW) 4x2

Item: 25, Ford, F-550 Regular Cab, F5G

Description: Refer FSA Base Specifications PDF document.

Model Upgrade/Downgrade:

Zone	Rank	Vendor	Price	Build File	Options File
Western	Primary	BOZARD FORD	\$60,858.00	Build	Options
	Alternate	Duval Ford LLC	\$61,073.00	Build	Options
	Alternate	Bachrodt FT, LLC dba Palmetto Ford of Miami	\$61,109.00	Build	Options
Northern	Primary	Bachrodt FT, LLC dba Palmetto Ford of Miami	\$60,809.00	Build	Options
	Alternate	BOZARD FORD	\$60,858.00	Build	Options
	Alternate	Duval Ford LLC	\$60,863.00	Build	Options
Central	Primary	Bachrodt FT, LLC dba Palmetto Ford of Miami	\$60,709.00	Build	Options
	Alternate	BOZARD FORD	\$60,993.00	Build	Options
	Alternate	Duval Ford LLC	\$61,073.00	Build	Options
Southern	Primary	Bachrodt FT, LLC dba Palmetto Ford of Miami	\$60,709.00	Build	Options
	Alternate	BOZARD FORD	\$60,993.00	Build	Options
	Alternate	Duval Ford LLC	\$61,098.00	Build	Options

Bid Award**Contract:** FSA25-VEH23.0, Heavy Trucks and Buses**Group:** Cab and Chassis Trucks: 17,500 lbs. GVWR (DRW) 4x2**Item:** 26, Ford, F-550 Super Cab, X5G**Description:** Refer FSA Base Specifications PDF document.**Model Upgrade/Downgrade:**

Zone	Rank	Vendor	Price	Build File	Options File
Western	Primary	BOZARD FORD	\$62,229.00	Build	Options
	Alternate	Duval Ford LLC	\$62,452.00	Build	Options
	Alternate	Bachrodt FT, LLC dba Palmetto Ford of Miami	\$62,476.00	Build	Options
Northern	Primary	Bachrodt FT, LLC dba Palmetto Ford of Miami	\$62,176.00	Build	Options
	Alternate	BOZARD FORD	\$62,229.00	Build	Options
	Alternate	Duval Ford LLC	\$62,242.00	Build	Options
Central	Primary	Bachrodt FT, LLC dba Palmetto Ford of Miami	\$62,076.00	Build	Options
	Alternate	BOZARD FORD	\$62,367.00	Build	Options
	Alternate	Duval Ford LLC	\$62,452.00	Build	Options
Southern	Primary	Bachrodt FT, LLC dba Palmetto Ford of Miami	\$62,076.00	Build	Options
	Alternate	BOZARD FORD	\$62,367.00	Build	Options
	Alternate	Duval Ford LLC	\$62,477.00	Build	Options

Bid Award**Contract:** FSA25-VEH23.0, Heavy Trucks and Buses**Group:** Cab and Chassis Trucks: 17,500 lbs. GVWR (DRW) 4x2**Item:** 27, Ford, F-600 Super Cab, F6K**Description:** Refer FSA Base Specifications PDF document.**Model Upgrade/Downgrade:**

Zone	Rank	Vendor	Price	Build File	Options File
Western	Primary	BOZARD FORD	\$62,371.00	Build	Options
	Alternate	Duval Ford LLC	\$62,596.00	Build	Options
	Alternate	Bachrodt FT, LLC dba Palmetto Ford of Miami	\$62,618.00	Build	Options
Northern	Primary	Bachrodt FT, LLC dba Palmetto Ford of Miami	\$62,318.00	Build	Options
	Alternate	BOZARD FORD	\$62,371.00	Build	Options
	Alternate	Duval Ford LLC	\$62,386.00	Build	Options
Central	Primary	Bachrodt FT, LLC dba Palmetto Ford of Miami	\$62,218.00	Build	Options
	Alternate	BOZARD FORD	\$62,509.00	Build	Options
	Alternate	Duval Ford LLC	\$62,596.00	Build	Options
Southern	Primary	Bachrodt FT, LLC dba Palmetto Ford of Miami	\$62,218.00	Build	Options
	Alternate	BOZARD FORD	\$62,509.00	Build	Options
	Alternate	Duval Ford LLC	\$62,621.00	Build	Options

Bid Award

Contract: FSA25-VEH23.0, Heavy Trucks and Buses

Group: Cab and Chassis Trucks: 17,500 lbs. GVWR (DRW) 4x2

Item: 28, International, CV, 515

Description: Refer FSA Base Specifications PDF document.

Model Upgrade/Downgrade:

Zone	Rank	Vendor	Price	Build File	Options File
Western	Primary	Cumberland International Trucks of Florida	\$69,650.00	Build	Options
Northern	Primary	Cumberland International Trucks of Florida	\$68,900.00	Build	Options
Central	Primary	Sun State International Trucks	\$68,825.00	Build	Options
	Alternate	Cumberland International Trucks of Florida	\$68,900.00	Build	Options
Southern	Primary	Rechtien International Trucks	\$69,660.00	Build	Options

Bid Award

Contract: FSA25-VEH23.0, Heavy Trucks and Buses

Group: Cab and Chassis Trucks: 17,500 lbs. GVWR (DRW) 4x2

Item: 29, Kenworth, T180, T180

Description: Refer FSA Base Specifications PDF document.

Model Upgrade/Downgrade:

Zone	Rank	Vendor	Price	Build File	Options File
Western					
Northern	Primary	Kenworth of Jacksonville	\$95,459.00	Build	Options
	Alternate	Florida Kenworth, LLC	\$95,939.00	Build	Options
Central	Primary	Florida Kenworth, LLC	\$90,939.00	Build	Options
	Alternate	All Roads Kenworth, LLC.	\$94,890.00	Build	Options
Southern	Primary	Florida Kenworth, LLC	\$90,939.00	Build	Options
	Alternate	All Roads Kenworth, LLC.	\$94,890.00	Build	Options

Bid Award

Contract: FSA25-VEH23.0, Heavy Trucks and Buses

Group: Cab and Chassis Trucks: 17,500 lbs. GVWR (DRW) 4x2

Item: 30, Peterbilt, 535, 535

Description: Refer FSA Base Specifications PDF document.

Model Upgrade/Downgrade:

Zone	Rank	Vendor	Price	Build File	Options File
Western	Primary	Rush Truck Centers of Florida, Inc.	\$102,010.00	Build	Options
Northern	Primary	Rush Truck Centers of Florida, Inc.	\$102,010.00	Build	Options
Central	Primary	Rush Truck Centers of Florida, Inc.	\$102,010.00	Build	Options
Southern	Primary	The Peterbilt Store South Florida LLC	\$104,969.00	Build	Options

Bid Award

Contract: FSA25-VEH23.0, Heavy Trucks and Buses

Group: Cab and Chassis Trucks: 17,500 lbs. GVWR (DRW) 4x2

Item: 31, Ram, 5500 Crew Cab Chassis 4x2 (173.4" WB - CA of 60"), DP5L93

Description: Refer FSA Base Specifications PDF document.

Model Upgrade/Downgrade:

Zone	Rank	Vendor	Price	Build File	Options File
Western	Primary	Beck Chrysler Dodge Jeep	\$61,935.00	Build	
Northern	Primary	Beck Chrysler Dodge Jeep	\$61,935.00	Build	
Central	Primary	Beck Chrysler Dodge Jeep	\$61,935.00	Build	
Southern	Primary	Beck Chrysler Dodge Jeep	\$62,035.00	Build	

Bid Award

Contract: FSA25-VEH23.0, Heavy Trucks and Buses

Group: Cab and Chassis Trucks: 17,500 lbs. GVWR (DRW) 4x2

Item: 32, Ram, 5500 Crew Cab Chassis 4x2 (197.4" WB - CA of 84"), DP5L94

Description: Refer FSA Base Specifications PDF document.

Model Upgrade/Downgrade:

Zone	Rank	Vendor	Price	Build File	Options File
Western	Primary	Beck Chrysler Dodge Jeep	\$62,119.00	Build	
Northern	Primary	Beck Chrysler Dodge Jeep	\$62,119.00	Build	
Central	Primary	Beck Chrysler Dodge Jeep	\$62,119.00	Build	
Southern	Primary	Beck Chrysler Dodge Jeep	\$62,119.00	Build	

Bid Award

Contract: FSA25-VEH23.0, Heavy Trucks and Buses

Group: Cab and Chassis Trucks: 17,500 lbs. GVWR (DRW) 4x2

Item: 33, Ram, 5500 Regular Cab Chassis 4x2 (144.5" WB - CA of 60"), DP5L63

Description: Refer FSA Base Specifications PDF document.

Model Upgrade/Downgrade:

Zone	Rank	Vendor	Price	Build File	Options File
Western	Primary	Beck Chrysler Dodge Jeep	\$60,972.00	Build	
Northern	Primary	Beck Chrysler Dodge Jeep	\$60,972.00	Build	
Central	Primary	Beck Chrysler Dodge Jeep	\$60,972.00	Build	
Southern					

Bid Award

Contract: FSA25-VEH23.0, Heavy Trucks and Buses

Group: Cab and Chassis Trucks: 17,500 lbs. GVWR (DRW) 4x2

Item: 34, Ram, 5500 Regular Cab Chassis 4x2 (168.5" WB - CA of 84"), DP5L64

Description: Refer FSA Base Specifications PDF document.

Model Upgrade/Downgrade:

Zone	Rank	Vendor	Price	Build File	Options File
Western	Primary	Beck Chrysler Dodge Jeep	\$61,060.00	Build	
Northern	Primary	Beck Chrysler Dodge Jeep	\$61,060.00	Build	
Central	Primary	Beck Chrysler Dodge Jeep	\$61,060.00	Build	
Southern	Primary	Beck Chrysler Dodge Jeep	\$61,160.00	Build	

Bid Award

Contract: FSA25-VEH23.0, Heavy Trucks and Buses

Group: Cab and Chassis Trucks: 17,500 lbs. GVWR (DRW) 4x2

Item: 35, Ram, 5500 Regular Cab Chassis 4x2 (192.5" WB - CA of 108"), DP5L65

Description: Refer FSA Base Specifications PDF document.

Model Upgrade/Downgrade:

Zone	Rank	Vendor	Price	Build File	Options File
Western	Primary	Beck Chrysler Dodge Jeep	\$58,835.00	Build	
Northern	Primary	Beck Chrysler Dodge Jeep	\$58,835.00	Build	
Central	Primary	Beck Chrysler Dodge Jeep	\$58,835.00	Build	
Southern	Primary	Beck Chrysler Dodge Jeep	\$58,935.00	Build	

Bid Award

Contract: FSA25-VEH23.0, Heavy Trucks and Buses

Group: Cab and Chassis Trucks: 17,500 lbs. GVWR (DRW) 4x2

Item: 36, Ram, 5500 Regular Cab Chassis 4x2 (204.5" WB - CA of 120"), DP5L66

Description: Refer FSA Base Specifications PDF document.

Model Upgrade/Downgrade:

Zone	Rank	Vendor	Price	Build File	Options File
Western	Primary	Beck Chrysler Dodge Jeep	\$59,024.00	Build	
Northern	Primary	Beck Chrysler Dodge Jeep	\$59,024.00	Build	
Central	Primary	Beck Chrysler Dodge Jeep	\$59,024.00	Build	
Southern	Primary	Beck Chrysler Dodge Jeep	\$59,124.00	Build	

Bid Award**Contract:** FSA25-VEH23.0, Heavy Trucks and Buses**Group:** Cab and Chassis Trucks: 17,500 lbs. GVWR (DRW) 4x4**Item:** 37, Ford, F-550 Crew Cab, W5H**Description:** Refer FSA Base Specifications PDF document.**Model Upgrade/Downgrade:**

Zone	Rank	Vendor	Price	Build File	Options File
Western	Primary	BOZARD FORD	\$67,180.00	Build	Options
	Alternate	Bachrodt FT, LLC dba Palmetto Ford of Miami	\$67,415.00	Build	Options
	Alternate	Duval Ford LLC	\$67,437.00	Build	Options
Northern	Primary	Bachrodt FT, LLC dba Palmetto Ford of Miami	\$67,115.00	Build	Options
	Alternate	BOZARD FORD	\$67,180.00	Build	Options
	Alternate	Duval Ford LLC	\$67,227.00	Build	Options
Central	Primary	Bachrodt FT, LLC dba Palmetto Ford of Miami	\$67,015.00	Build	Options
	Alternate	BOZARD FORD	\$67,329.00	Build	Options
	Alternate	Duval Ford LLC	\$67,437.00	Build	Options
Southern	Primary	Bachrodt FT, LLC dba Palmetto Ford of Miami	\$67,015.00	Build	Options
	Alternate	BOZARD FORD	\$67,329.00	Build	Options
	Alternate	Duval Ford LLC	\$67,462.00	Build	Options

Bid Award**Contract:** FSA25-VEH23.0, Heavy Trucks and Buses**Group:** Cab and Chassis Trucks: 17,500 lbs. GVWR (DRW) 4x4**Item:** 38, Ford, F-550 Regular Cab, F5H**Description:** Refer FSA Base Specifications PDF document.**Model Upgrade/Downgrade:**

Zone	Rank	Vendor	Price	Build File	Options File
Western	Primary	BOZARD FORD	\$63,506.00	Build	Options
	Alternate	Duval Ford LLC	\$63,738.00	Build	Options
	Alternate	Bachrodt FT, LLC dba Palmetto Ford of Miami	\$63,749.00	Build	Options
Northern	Primary	Bachrodt FT, LLC dba Palmetto Ford of Miami	\$63,449.00	Build	Options
	Alternate	BOZARD FORD	\$63,506.00	Build	Options
	Alternate	Duval Ford LLC	\$63,528.00	Build	Options
Central	Primary	Bachrodt FT, LLC dba Palmetto Ford of Miami	\$63,349.00	Build	Options
	Alternate	BOZARD FORD	\$63,646.00	Build	Options
	Alternate	Duval Ford LLC	\$63,738.00	Build	Options
Southern	Primary	Bachrodt FT, LLC dba Palmetto Ford of Miami	\$63,349.00	Build	Options
	Alternate	BOZARD FORD	\$63,646.00	Build	Options
	Alternate	Duval Ford LLC	\$63,763.00	Build	Options

Bid Award**Contract:** FSA25-VEH23.0, Heavy Trucks and Buses**Group:** Cab and Chassis Trucks: 17,500 lbs. GVWR (DRW) 4x4**Item:** 39, Ford, F-550 Super Cab, X5H**Description:** Refer FSA Base Specifications PDF document.**Model Upgrade/Downgrade:**

Zone	Rank	Vendor	Price	Build File	Options File
Western	Primary	BOZARD FORD	\$65,728.00	Build	Options
	Alternate	Bachrodt FT, LLC dba Palmetto Ford of Miami	\$65,966.00	Build	Options
	Alternate	Duval Ford LLC	\$65,975.00	Build	Options
Northern	Primary	Bachrodt FT, LLC dba Palmetto Ford of Miami	\$65,666.00	Build	Options
	Alternate	BOZARD FORD	\$65,728.00	Build	Options
	Alternate	Duval Ford LLC	\$65,765.00	Build	Options
Central	Primary	Bachrodt FT, LLC dba Palmetto Ford of Miami	\$65,566.00	Build	Options
	Alternate	BOZARD FORD	\$65,873.00	Build	Options
	Alternate	Duval Ford LLC	\$65,975.00	Build	Options
Southern	Primary	Bachrodt FT, LLC dba Palmetto Ford of Miami	\$65,566.00	Build	Options
	Alternate	BOZARD FORD	\$65,873.00	Build	Options
	Alternate	Duval Ford LLC	\$66,000.00	Build	Options

Bid Award**Contract:** FSA25-VEH23.0, Heavy Trucks and Buses**Group:** Cab and Chassis Trucks: 17,500 lbs. GVWR (DRW) 4x4**Item:** 40, Ford, F-600 Regular Cab, F6L**Description:** Refer FSA Base Specifications PDF document.**Model Upgrade/Downgrade:**

Zone	Rank	Vendor	Price	Build File	Options File
Western	Primary	BOZARD FORD	\$65,020.00	Build	Options
	Alternate	Bachrodt FT, LLC dba Palmetto Ford of Miami	\$65,260.00	Build	Options
	Alternate	Duval Ford LLC	\$65,262.00	Build	Options
Northern	Primary	Bachrodt FT, LLC dba Palmetto Ford of Miami	\$64,960.00	Build	Options
	Alternate	BOZARD FORD	\$65,020.00	Build	Options
	Alternate	Duval Ford LLC	\$65,052.00	Build	Options
Central	Primary	Bachrodt FT, LLC dba Palmetto Ford of Miami	\$64,860.00	Build	Options
	Alternate	BOZARD FORD	\$65,163.00	Build	Options
	Alternate	Duval Ford LLC	\$65,262.00	Build	Options
Southern	Primary	Bachrodt FT, LLC dba Palmetto Ford of Miami	\$64,860.00	Build	Options
	Alternate	BOZARD FORD	\$65,163.00	Build	Options
	Alternate	Duval Ford LLC	\$65,287.00	Build	Options

Bid Award

Contract: FSA25-VEH23.0, Heavy Trucks and Buses

Group: Cab and Chassis Trucks: 17,500 lbs. GVWR (DRW) 4x4

Item: 41, International, CV, 515

Description: Refer FSA Base Specifications PDF document.

Model Upgrade/Downgrade:

Zone	Rank	Vendor	Price	Build File	Options File
Western	Primary	Cumberland International Trucks of Florida	\$73,445.00	Build	Options
Northern	Primary	Cumberland International Trucks of Florida	\$72,695.00	Build	Options
Central	Primary	Cumberland International Trucks of Florida	\$72,695.00	Build	Options
	Alternate	Sun State International Trucks	\$72,755.00	Build	Options
Southern	Primary	Rechtien International Trucks	\$73,600.00	Build	Options

Bid Award

Contract: FSA25-VEH23.0, Heavy Trucks and Buses

Group: Cab and Chassis Trucks: 17,500 lbs. GVWR (DRW) 4x4

Item: 42, Ram, 5500 Crew Cab Chassis 4x4 (173.4" WB - CA of 60"), DP0L93

Description: Refer FSA Base Specifications PDF document.

Model Upgrade/Downgrade:

Zone	Rank	Vendor	Price	Build File	Options File
Western	Primary	Beck Chrysler Dodge Jeep	\$65,456.00	Build	
Northern	Primary	Beck Chrysler Dodge Jeep	\$65,456.00	Build	
Central	Primary	Beck Chrysler Dodge Jeep	\$65,456.00	Build	
Southern	Primary	Beck Chrysler Dodge Jeep	\$65,556.00	Build	

Bid Award

Contract: FSA25-VEH23.0, Heavy Trucks and Buses

Group: Cab and Chassis Trucks: 17,500 lbs. GVWR (DRW) 4x4

Item: 43, Ram, 5500 Crew Cab Chassis 4x4 (197.4" WB - CA of 84"), DP0L94

Description: Refer FSA Base Specifications PDF document.

Model Upgrade/Downgrade:

Zone	Rank	Vendor	Price	Build File	Options File
Western	Primary	Beck Chrysler Dodge Jeep	\$65,368.00	Build	
Northern	Primary	Beck Chrysler Dodge Jeep	\$65,368.00	Build	
Central	Primary	Beck Chrysler Dodge Jeep	\$65,368.00	Build	
Southern	Primary	Beck Chrysler Dodge Jeep	\$65,468.00	Build	

Bid Award

Contract: FSA25-VEH23.0, Heavy Trucks and Buses

Group: Cab and Chassis Trucks: 17,500 lbs. GVWR (DRW) 4x4

Item: 44, Ram, 5500 Regular Cab Chassis 4x4 (144.5" WB - CA of 60"), DP0L63

Description: Refer FSA Base Specifications PDF document.

Model Upgrade/Downgrade:

Zone	Rank	Vendor	Price	Build File	Options File
Western	Primary	Beck Chrysler Dodge Jeep	\$61,834.00	Build	
Northern	Primary	Beck Chrysler Dodge Jeep	\$61,834.00	Build	
Central	Primary	Beck Chrysler Dodge Jeep	\$61,834.00	Build	
Southern	Primary	Beck Chrysler Dodge Jeep	\$61,934.00	Build	

Bid Award

Contract: FSA25-VEH23.0, Heavy Trucks and Buses

Group: Cab and Chassis Trucks: 17,500 lbs. GVWR (DRW) 4x4

Item: 45, Ram, 5500 Regular Cab Chassis 4x4 (168.5" WB - CA of 84"), DP0L64

Description: Refer FSA Base Specifications PDF document.

Model Upgrade/Downgrade:

Zone	Rank	Vendor	Price	Build File	Options File
Western	Primary	Beck Chrysler Dodge Jeep	\$61,893.00	Build	
Northern	Primary	Beck Chrysler Dodge Jeep	\$61,893.00	Build	
Central	Primary	Beck Chrysler Dodge Jeep	\$61,893.00	Build	
Southern	Primary	Beck Chrysler Dodge Jeep	\$61,993.00	Build	

Bid Award

Contract: FSA25-VEH23.0, Heavy Trucks and Buses

Group: Cab and Chassis Trucks: 17,500 lbs. GVWR (DRW) 4x4

Item: 46, Ram, 5500 Regular Cab Chassis 4x4 (192.5" WB - CA of 108"), DP0L65

Description: Refer FSA Base Specifications PDF document.

Model Upgrade/Downgrade:

Zone	Rank	Vendor	Price	Build File	Options File
Western	Primary	Beck Chrysler Dodge Jeep	\$62,082.00	Build	
Northern	Primary	Beck Chrysler Dodge Jeep	\$62,082.00	Build	
Central	Primary	Beck Chrysler Dodge Jeep	\$62,082.00	Build	
Southern	Primary	Beck Chrysler Dodge Jeep	\$62,182.00	Build	

Bid Award

Contract: FSA25-VEH23.0, Heavy Trucks and Buses

Group: Cab and Chassis Trucks: 17,500 lbs. GVWR (DRW) 4x4

Item: 47, Ram, 5500 Regular Cab Chassis 4x4 (204.5" WB - CA of 120"), DP0L66

Description: Refer FSA Base Specifications PDF document.

Model Upgrade/Downgrade:

Zone	Rank	Vendor	Price	Build File	Options File
Western	Primary	Beck Chrysler Dodge Jeep	\$62,417.00	Build	
Northern	Primary	Beck Chrysler Dodge Jeep	\$62,417.00	Build	
Central	Primary	Beck Chrysler Dodge Jeep	\$62,417.00	Build	
Southern	Primary	Beck Chrysler Dodge Jeep	\$62,517.00	Build	

Bid Award**Contract:** FSA25-VEH23.0, Heavy Trucks and Buses**Group:** Cab and Chassis Trucks: 25,000 lbs. GVWR (DRW) 4x2 Tilt Cab**Item:** 48, Battle Motors, Striker, Striker**Description:** Refer FSA Base Specifications PDF document.**Model Upgrade/Downgrade:**

Zone	Rank	Vendor	Price	Build File	Options File
Western	Primary	RDK Assets Inc	\$139,763.00	Build	Options
	Alternate	Container Systems & Equipment Co., Inc.	\$171,707.00	Build	Options
Northern	Primary	RDK Assets Inc	\$139,763.00	Build	Options
	Alternate	Container Systems & Equipment Co., Inc.	\$171,707.00	Build	Options
Central	Primary	RDK Assets Inc	\$139,763.00	Build	Options
	Alternate	Container Systems & Equipment Co., Inc.	\$171,707.00	Build	Options
Southern	Primary	RDK Assets Inc	\$139,763.00	Build	Options
	Alternate	Container Systems & Equipment Co., Inc.	\$171,707.00	Build	Options

Bid Award

Contract: FSA25-VEH23.0, Heavy Trucks and Buses

Group: Cab and Chassis Trucks: 25,000 lbs. GVWR (DRW) 4x2 Tilt Cab

Item: 49, Isuzu, FTR Chassis, MT1/G1

Description: Refer FSA Base Specifications PDF document.

Model Upgrade/Downgrade:

Zone	Rank	Vendor	Price	Build File	Options File
Western	Primary	DeLand Truck Center, Inc.	\$84,257.00	Build	Options
	Alternate	Nextran Truck Centers	\$91,644.00	Build	Options
Northern	Primary	DeLand Truck Center, Inc.	\$84,257.00	Build	Options
	Alternate	Nextran Truck Centers	\$91,644.00	Build	Options
Central	Primary	DeLand Truck Center, Inc.	\$84,257.00	Build	Options
	Alternate	Nextran Truck Centers	\$91,644.00	Build	Options
Southern	Primary	DeLand Truck Center, Inc.	\$84,257.00	Build	Options
	Alternate	Nextran Truck Centers	\$91,644.00	Build	Options

Bid Award

Contract: FSA25-VEH23.0, Heavy Trucks and Buses

Group: Cab and Chassis Trucks: 25,000 lbs. GVWR (DRW) 4x2 Tilt Cab

Item: 50, Kenworth, K270, K270

Description: Refer FSA Base Specifications PDF document.

Model Upgrade/Downgrade:

Zone	Rank	Vendor	Price	Build File	Options File
Western					
Northern	Primary	Kenworth of Jacksonville	\$97,639.00	Build	Options
Central	Primary	All Roads Kenworth, LLC.	\$113,900.00	Build	Options
Southern	Primary	All Roads Kenworth, LLC.	\$113,900.00	Build	Options

Bid Award**Contract:** FSA25-VEH23.0, Heavy Trucks and Buses**Group:** Cab and Chassis Trucks: 25,500 lbs. GVWR (DRW) 4x2**Item:** 51, Ford, F-650 Regular Cab, F6D**Description:** Refer FSA Base Specifications PDF document.**Model Upgrade/Downgrade:**

Zone	Rank	Vendor	Price	Build File	Options File
Western	Primary	BOZARD FORD	\$68,466.00	Build	Options
	Alternate	Bachrodt FT, LLC dba Palmetto Ford of Miami	\$68,505.00	Build	Options
	Alternate	Duval Ford LLC	\$69,434.00	Build	Options
Northern	Primary	Bachrodt FT, LLC dba Palmetto Ford of Miami	\$68,405.00	Build	Options
	Alternate	BOZARD FORD	\$68,466.00	Build	Options
	Alternate	Duval Ford LLC	\$69,225.00	Build	Options
Central	Primary	Bachrodt FT, LLC dba Palmetto Ford of Miami	\$68,305.00	Build	Options
	Alternate	BOZARD FORD	\$68,618.00	Build	Options
	Alternate	Duval Ford LLC	\$69,296.00	Build	Options
Southern	Primary	Bachrodt FT, LLC dba Palmetto Ford of Miami	\$68,305.00	Build	Options
	Alternate	BOZARD FORD	\$68,618.00	Build	Options
	Alternate	Duval Ford LLC	\$69,434.00	Build	Options

Bid Award

Contract: FSA25-VEH23.0, Heavy Trucks and Buses

Group: Cab and Chassis Trucks: 25,500 lbs. GVWR (DRW) 4x2

Item: 52, Freightliner, M2, 106

Description: Refer FSA Base Specifications PDF document.

Model Upgrade/Downgrade:

Zone	Rank	Vendor	Price	Build File	Options File
Western	Primary	SBL Freightliner, LLC	\$81,500.00	Build	Options
	Alternate	Tampa Truck Center	\$83,987.00	Build	Options
Northern	Primary	SBL Freightliner, LLC	\$81,900.00	Build	Options
	Alternate	Tampa Truck Center	\$83,987.00	Build	Options
Central	Primary	SBL Freightliner, LLC	\$81,900.00	Build	Options
	Alternate	Tampa Truck Center	\$83,987.00	Build	Options
Southern	Primary	SBL Freightliner, LLC	\$81,400.00	Build	Options
	Alternate	Tampa Truck Center	\$83,987.00	Build	Options

Bid Award

Contract: FSA25-VEH23.0, Heavy Trucks and Buses

Group: Cab and Chassis Trucks: 25,500 lbs. GVWR (DRW) 4x2

Item: 53, Hino, L6, L6

Description: Refer FSA Base Specifications PDF document.

Model Upgrade/Downgrade:

Zone	Rank	Vendor	Price	Build File	Options File
Western	Primary	TRUCKMAX, INC.	\$78,327.00	Build	Options
	Alternate	Nextran Truck Centers	\$83,416.00	Build	Options
Northern	Primary	TRUCKMAX, INC.	\$78,327.00	Build	Options
	Alternate	Nextran Truck Centers	\$83,416.00	Build	Options
	Alternate	Florida Kenworth, LLC	\$86,924.00	Build	Options
Central	Primary	TRUCKMAX, INC.	\$78,327.00	Build	Options
	Alternate	Florida Kenworth, LLC	\$81,924.00	Build	Options
Southern	Primary	TRUCKMAX, INC.	\$78,327.00	Build	Options
	Alternate	Florida Kenworth, LLC	\$81,924.00	Build	Options

Bid Award

Contract: FSA25-VEH23.0, Heavy Trucks and Buses

Group: Cab and Chassis Trucks: 25,500 lbs. GVWR (DRW) 4x2

Item: 54, International, MV, 607

Description: Refer FSA Base Specifications PDF document.

Model Upgrade/Downgrade:

Zone	Rank	Vendor	Price	Build File	Options File
Western	Primary	Cumberland International Trucks of Florida	\$86,250.00	Build	Options
Northern	Primary	Cumberland International Trucks of Florida	\$85,500.00	Build	Options
Central	Primary	Cumberland International Trucks of Florida	\$85,500.00	Build	Options
	Alternate	Sun State International Trucks	\$86,464.00	Build	Options
Southern	Primary	Rechtien International Trucks	\$86,750.00	Build	Options

Bid Award

Contract: FSA25-VEH23.0, Heavy Trucks and Buses

Group: Cab and Chassis Trucks: 25,500 lbs. GVWR (DRW) 4x2

Item: 55, Kenworth, T280, T280

Description: Refer FSA Base Specifications PDF document.

Model Upgrade/Downgrade:

Zone	Rank	Vendor	Price	Build File	Options File
Western					
Northern	Primary	Florida Kenworth, LLC	\$96,768.00	Build	Options
	Alternate	Kenworth of Jacksonville	\$98,829.00	Build	Options
Central	Primary	Florida Kenworth, LLC	\$91,768.00	Build	Options
	Alternate	All Roads Kenworth, LLC.	\$94,944.00	Build	Options
Southern	Primary	Florida Kenworth, LLC	\$91,768.00	Build	Options
	Alternate	All Roads Kenworth, LLC.	\$94,944.00	Build	Options

Bid Award

Contract: FSA25-VEH23.0, Heavy Trucks and Buses

Group: Cab and Chassis Trucks: 25,500 lbs. GVWR (DRW) 4x2

Item: 56, Mack, MD6, MD6

Description: Refer FSA Base Specifications PDF document.

Model Upgrade/Downgrade:

Zone	Rank	Vendor	Price	Build File	Options File
Western	Primary	Nextran Truck Centers	\$84,931.00	Build	Options
Northern	Primary	Nextran Truck Centers	\$84,931.00	Build	Options
Central	Primary	Nextran Truck Centers	\$84,931.00	Build	Options
Southern	Primary	Nextran Truck Centers	\$84,931.00	Build	Options

Bid Award

Contract: FSA25-VEH23.0, Heavy Trucks and Buses

Group: Cab and Chassis Trucks: 25,500 lbs. GVWR (DRW) 4x2

Item: 57, Peterbilt, 536, 536

Description: Refer FSA Base Specifications PDF document.

Model Upgrade/Downgrade:

Zone	Rank	Vendor	Price	Build File	Options File
Western	Primary	Rush Truck Centers of Florida, Inc.	\$100,000.00	Build	Options
Northern	Primary	Rush Truck Centers of Florida, Inc.	\$100,000.00	Build	Options
Central	Primary	Rush Truck Centers of Florida, Inc.	\$100,000.00	Build	Options
Southern	Primary	The Peterbilt Store South Florida LLC	\$100,850.00	Build	Options

Bid Award**Contract:** FSA25-VEH23.0, Heavy Trucks and Buses**Group:** Cab and Chassis Trucks: 30,000 lbs. GVWR (DRW) 4x2**Item:** 58, Ford, F-750 Regular Cab, F7D**Description:** Refer FSA Base Specifications PDF document.**Model Upgrade/Downgrade:**

Zone	Rank	Vendor	Price	Build File	Options File
Western	Primary	BOZARD FORD	\$70,099.00	Build	Options
	Alternate	Bachrodt FT, LLC dba Palmetto Ford of Miami	\$70,133.00	Build	Options
	Alternate	Duval Ford LLC	\$71,072.00	Build	Options
Northern	Primary	Bachrodt FT, LLC dba Palmetto Ford of Miami	\$70,033.00	Build	Options
	Alternate	BOZARD FORD	\$70,099.00	Build	Options
	Alternate	Duval Ford LLC	\$70,863.00	Build	Options
Central	Primary	Bachrodt FT, LLC dba Palmetto Ford of Miami	\$69,933.00	Build	Options
	Alternate	BOZARD FORD	\$70,254.00	Build	Options
	Alternate	Duval Ford LLC	\$70,934.00	Build	Options
Southern	Primary	Bachrodt FT, LLC dba Palmetto Ford of Miami	\$69,933.00	Build	Options
	Alternate	BOZARD FORD	\$70,254.00	Build	Options
	Alternate	Duval Ford LLC	\$71,072.00	Build	Options

Bid Award**Contract:** FSA25-VEH23.0, Heavy Trucks and Buses**Group:** Cab and Chassis Trucks: 30,000 lbs. GVWR (DRW) 4x2**Item:** 59, Freightliner, M2, 106**Description:** Refer FSA Base Specifications PDF document.**Model Upgrade/Downgrade:**

Zone	Rank	Vendor	Price	Build File	Options File
Western	Primary	Tampa Truck Center	\$84,287.00	Build	Options
	Alternate	Orlando Freightliner	\$85,150.00	Build	Options
	Alternate	SBL Freightliner, LLC	\$85,600.00	Build	Options
Northern	Primary	Tampa Truck Center	\$84,287.00	Build	Options
	Alternate	Orlando Freightliner	\$84,688.00	Build	Options
	Alternate	SBL Freightliner, LLC	\$85,600.00	Build	Options
Central	Primary	Orlando Freightliner	\$83,688.00	Build	Options
	Alternate	Tampa Truck Center	\$84,287.00	Build	Options
	Alternate	SBL Freightliner, LLC	\$85,600.00	Build	Options
Southern	Primary	SBL Freightliner, LLC	\$83,400.00	Build	Options
	Alternate	Orlando Freightliner	\$84,250.00	Build	Options
	Alternate	Tampa Truck Center	\$84,788.00	Build	Options

Bid Award

Contract: FSA25-VEH23.0, Heavy Trucks and Buses

Group: Cab and Chassis Trucks: 30,000 lbs. GVWR (DRW) 4x2

Item: 60, Hino, L7, L7

Description: Refer FSA Base Specifications PDF document.

Model Upgrade/Downgrade:

Zone	Rank	Vendor	Price	Build File	Options File
Western	Primary	TRUCKMAX, INC.	\$79,827.00	Build	Options
	Alternate	Nextran Truck Centers	\$85,433.00	Build	Options
Northern	Primary	TRUCKMAX, INC.	\$79,827.00	Build	Options
	Alternate	Nextran Truck Centers	\$85,433.00	Build	Options
	Alternate	Florida Kenworth, LLC	\$88,582.00	Build	Options
Central	Primary	TRUCKMAX, INC.	\$79,827.00	Build	Options
	Alternate	Florida Kenworth, LLC	\$83,582.00	Build	Options
Southern	Primary	TRUCKMAX, INC.	\$79,827.00	Build	Options
	Alternate	Florida Kenworth, LLC	\$83,582.00	Build	Options

Bid Award

Contract: FSA25-VEH23.0, Heavy Trucks and Buses

Group: Cab and Chassis Trucks: 30,000 lbs. GVWR (DRW) 4x2

Item: 61, International, MV, 607

Description: Refer FSA Base Specifications PDF document.

Model Upgrade/Downgrade:

Zone	Rank	Vendor	Price	Build File	Options File
Western	Primary	Cumberland International Trucks of Florida	\$87,700.00	Build	Options
Northern	Primary	Cumberland International Trucks of Florida	\$86,950.00	Build	Options
Central	Primary	Cumberland International Trucks of Florida	\$86,950.00	Build	Options
	Alternate	Sun State International Trucks	\$87,875.00	Build	Options
Southern	Primary	Rechtien International Trucks	\$87,990.00	Build	Options

Bid Award**Contract:** FSA25-VEH23.0, Heavy Trucks and Buses**Group:** Cab and Chassis Trucks: 30,000 lbs. GVWR (DRW) 4x2**Item:** 62, Kenworth, T380, T380**Description:** Refer FSA Base Specifications PDF document.**Model Upgrade/Downgrade:**

Zone	Rank	Vendor	Price	Build File	Options File
Western					
Northern	Primary	Florida Kenworth, LLC	\$96,578.00	Build	Options
	Alternate	Kenworth of Jacksonville	\$98,845.00	Build	Options
Central	Primary	Florida Kenworth, LLC	\$91,578.00	Build	Options
	Alternate	All Roads Kenworth, LLC.	\$95,890.00	Build	Options
Southern	Primary	Florida Kenworth, LLC	\$91,578.00	Build	Options
	Alternate	All Roads Kenworth, LLC.	\$95,890.00	Build	Options

Bid Award

Contract: FSA25-VEH23.0, Heavy Trucks and Buses

Group: Cab and Chassis Trucks: 30,000 lbs. GVWR (DRW) 4x2

Item: 63, Kenworth, T480, T480

Description: Refer FSA Base Specifications PDF document.

Model Upgrade/Downgrade:

Zone	Rank	Vendor	Price	Build File	Options File
Western					
Northern	Primary	Florida Kenworth, LLC	\$103,763.00	Build	Options
	Alternate	Kenworth of Jacksonville	\$106,430.00	Build	Options
Central	Primary	All Roads Kenworth, LLC.	\$96,990.00	Build	Options
	Alternate	Florida Kenworth, LLC	\$98,763.00	Build	Options
Southern	Primary	All Roads Kenworth, LLC.	\$96,990.00	Build	Options
	Alternate	Florida Kenworth, LLC	\$98,763.00	Build	Options

Bid Award

Contract: FSA25-VEH23.0, Heavy Trucks and Buses

Group: Cab and Chassis Trucks: 30,000 lbs. GVWR (DRW) 4x2

Item: 64, Mack, MD7, MD7

Description: Refer FSA Base Specifications PDF document.

Model Upgrade/Downgrade:

Zone	Rank	Vendor	Price	Build File	Options File
Western	Primary	Nextran Truck Centers	\$90,294.00	Build	Options
Northern	Primary	Nextran Truck Centers	\$90,294.00	Build	Options
Central	Primary	Nextran Truck Centers	\$90,294.00	Build	Options
Southern	Primary	Nextran Truck Centers	\$90,294.00	Build	Options

Bid Award

Contract: FSA25-VEH23.0, Heavy Trucks and Buses

Group: Cab and Chassis Trucks: 30,000 lbs. GVWR (DRW) 4x2

Item: 65, Peterbilt, 537, 537

Description: Refer FSA Base Specifications PDF document.

Model Upgrade/Downgrade:

Zone	Rank	Vendor	Price	Build File	Options File
Western	Primary	Rush Truck Centers of Florida, Inc.	\$102,010.00	Build	Options
Northern	Primary	Rush Truck Centers of Florida, Inc.	\$102,010.00	Build	Options
Central	Primary	Rush Truck Centers of Florida, Inc.	\$102,010.00	Build	Options
Southern	Primary	The Peterbilt Store South Florida LLC	\$101,135.00	Build	Options

Bid Award

Contract: FSA25-VEH23.0, Heavy Trucks and Buses

Group: Cab and Chassis Trucks: 30,000 lbs. GVWR (DRW) 4x2

Item: 66, Western Star, 47X, 47X

Description: Refer FSA Base Specifications PDF document.

Model Upgrade/Downgrade:

Zone	Rank	Vendor	Price	Build File	Options File
Western	Primary	Tampa Truck Center	\$117,655.00	Build	Options
	Alternate	Orlando Freightliner	\$118,473.00	Build	Options
Northern	Primary	Tampa Truck Center	\$118,200.00	Build	Options
	Alternate	Orlando Freightliner	\$118,473.00	Build	Options
Central	Primary	Orlando Freightliner	\$117,473.00	Build	Options
	Alternate	Tampa Truck Center	\$118,200.00	Build	Options
Southern	Primary	Orlando Freightliner	\$118,473.00	Build	Options
	Alternate	Tampa Truck Center	\$118,888.00	Build	Options

Bid Award**Contract:** FSA25-VEH23.0, Heavy Trucks and Buses**Group:** Cab and Chassis Trucks: 52,000 lbs. GVWR Semi Tractor 4x6**Item:** 67, Freightliner, M2, 114SD**Description:** Refer FSA Base Specifications PDF document.**Model Upgrade/Downgrade:**

Zone	Rank	Vendor	Price	Build File	Options File
Western	Primary	Tampa Truck Center	\$116,200.00	Build	Options
	Alternate	Orlando Freightliner	\$116,800.00	Build	Options
	Alternate	SBL Freightliner, LLC	\$117,600.00	Build	Options
Northern	Primary	Tampa Truck Center	\$116,400.00	Build	Options
	Alternate	Orlando Freightliner	\$116,800.00	Build	Options
	Alternate	SBL Freightliner, LLC	\$117,600.00	Build	Options
Central	Primary	Orlando Freightliner	\$115,917.00	Build	Options
	Alternate	Tampa Truck Center	\$116,400.00	Build	Options
	Alternate	SBL Freightliner, LLC	\$117,600.00	Build	Options
Southern	Primary	SBL Freightliner, LLC	\$115,600.00	Build	Options
	Alternate	Orlando Freightliner	\$116,800.00	Build	Options
	Alternate	Tampa Truck Center	\$116,950.00	Build	Options

Bid Award

Contract: FSA25-VEH23.0, Heavy Trucks and Buses

Group: Cab and Chassis Trucks: 52,000 lbs. GVWR Semi Tractor 4x6

Item: 68, International, HV, 615

Description: Refer FSA Base Specifications PDF document.

Model Upgrade/Downgrade:

Zone	Rank	Vendor	Price	Build File	Options File
Western	Primary	Cumberland International Trucks of Florida	\$128,250.00	Build	Options
Northern	Primary	Cumberland International Trucks of Florida	\$127,500.00	Build	Options
Central	Primary	Cumberland International Trucks of Florida	\$127,500.00	Build	Options
	Alternate	Sun State International Trucks	\$127,619.00	Build	Options
Southern	Primary	Rechtien International Trucks	\$127,650.00	Build	Options

Bid Award

Contract: FSA25-VEH23.0, Heavy Trucks and Buses

Group: Cab and Chassis Trucks: 52,000 lbs. GVWR Semi Tractor 4x6

Item: 69, International, HX, 620F

Description: Refer FSA Base Specifications PDF document.

Model Upgrade/Downgrade:

Zone	Rank	Vendor	Price	Build File	Options File
Western	Primary	Cumberland International Trucks of Florida	\$139,650.00	Build	Options
Northern	Primary	Cumberland International Trucks of Florida	\$138,900.00	Build	Options
Central	Primary	Cumberland International Trucks of Florida	\$138,900.00	Build	Options
	Alternate	Sun State International Trucks	\$138,995.00	Build	Options
Southern	Primary	Rechtien International Trucks	\$138,990.00	Build	Options

Bid Award

Contract: FSA25-VEH23.0, Heavy Trucks and Buses

Group: Cab and Chassis Trucks: 52,000 lbs. GVWR Semi Tractor 4x6

Item: 70, Kenworth, T880, T880

Description: Refer FSA Base Specifications PDF document.

Model Upgrade/Downgrade:

Zone	Rank	Vendor	Price	Build File	Options File
Western					
Northern	Primary	Florida Kenworth, LLC	\$140,831.00	Build	Options
	Alternate	Kenworth of Jacksonville	\$141,931.00	Build	Options
Central	Primary	Florida Kenworth, LLC	\$135,831.00	Build	Options
	Alternate	All Roads Kenworth, LLC.	\$144,205.00	Build	Options
Southern	Primary	Florida Kenworth, LLC	\$135,831.00	Build	Options
	Alternate	All Roads Kenworth, LLC.	\$144,205.00	Build	Options

Bid Award

Contract: FSA25-VEH23.0, Heavy Trucks and Buses

Group: Cab and Chassis Trucks: 52,000 lbs. GVWR Semi Tractor 4x6

Item: 71, Mack, AP or G Series, AP or G Series

Description: Refer FSA Base Specifications PDF document.

Model Upgrade/Downgrade:

Zone	Rank	Vendor	Price	Build File	Options File
Western	Primary	Nextran Truck Centers	\$142,462.00	Build	Options
Northern	Primary	Nextran Truck Centers	\$142,462.00	Build	Options
Central	Primary	Nextran Truck Centers	\$142,462.00	Build	Options
Southern	Primary	Nextran Truck Centers	\$142,462.00	Build	Options

Bid Award

Contract: FSA25-VEH23.0, Heavy Trucks and Buses

Group: Cab and Chassis Trucks: 52,000 lbs. GVWR Semi Tractor 4x6

Item: 72, Peterbilt, 567, 567

Description: Refer FSA Base Specifications PDF document.

Model Upgrade/Downgrade:

Zone	Rank	Vendor	Price	Build File	Options File
Western	Primary	Rush Truck Centers of Florida, Inc.	\$153,016.00	Build	Options
Northern	Primary	Rush Truck Centers of Florida, Inc.	\$153,016.00	Build	Options
Central	Primary	Rush Truck Centers of Florida, Inc.	\$153,016.00	Build	Options
Southern	Primary	The Peterbilt Store South Florida LLC	\$156,075.00	Build	Options

Bid Award

Contract: FSA25-VEH23.0, Heavy Trucks and Buses

Group: Cab and Chassis Trucks: 52,000 lbs. GVWR Semi Tractor 4x6

Item: 73, Volvo, V Series, V Series

Description: Refer FSA Base Specifications PDF document.

Model Upgrade/Downgrade:

Zone	Rank	Vendor	Price	Build File	Options File
Western	Primary	TRUCKMAX, INC.	\$115,309.00	Build	Options
	Alternate	Nextran Truck Centers	\$128,156.00	Build	Options
Northern	Primary	TRUCKMAX, INC.	\$115,309.00	Build	Options
	Alternate	Nextran Truck Centers	\$128,156.00	Build	Options
Central	Primary	TRUCKMAX, INC.	\$115,309.00	Build	Options
	Alternate	Nextran Truck Centers	\$128,156.00	Build	Options
Southern	Primary	TRUCKMAX, INC.	\$115,309.00	Build	Options
	Alternate	Nextran Truck Centers	\$128,156.00	Build	Options

Bid Award

Contract: FSA25-VEH23.0, Heavy Trucks and Buses

Group: Cab and Chassis Trucks: 52,000 lbs. GVWR Semi Tractor 4x6

Item: 74, Western Star, 47X, 47X

Description: Refer FSA Base Specifications PDF document.

Model Upgrade/Downgrade:

Zone	Rank	Vendor	Price	Build File	Options File
Western	Primary	Tampa Truck Center	\$136,800.00	Build	Options
	Alternate	Orlando Freightliner	\$137,337.00	Build	Options
Northern	Primary	Tampa Truck Center	\$137,100.00	Build	Options
	Alternate	Orlando Freightliner	\$137,337.00	Build	Options
Central	Primary	Orlando Freightliner	\$136,337.00	Build	Options
	Alternate	Tampa Truck Center	\$137,100.00	Build	Options
Southern	Primary	Orlando Freightliner	\$137,337.00	Build	Options
	Alternate	Tampa Truck Center	\$138,200.00	Build	Options

Bid Award**Contract:** FSA25-VEH23.0, Heavy Trucks and Buses**Group:** Cab and Chassis Trucks: 52,000 lbs. GVWR Truck 4x6**Item:** 75, Freightliner, M2, 112**Description:** Refer FSA Base Specifications PDF document.**Model Upgrade/Downgrade:**

Zone	Rank	Vendor	Price	Build File	Options File
Western	Primary	Tampa Truck Center	\$109,555.00	Build	Options
	Alternate	Orlando Freightliner	\$110,191.00	Build	Options
	Alternate	SBL Freightliner, LLC	\$110,900.00	Build	Options
Northern	Primary	Tampa Truck Center	\$110,300.00	Build	Options
	Alternate	Orlando Freightliner	\$110,541.00	Build	Options
	Alternate	SBL Freightliner, LLC	\$111,500.00	Build	Options
Central	Primary	Orlando Freightliner	\$109,541.00	Build	Options
	Alternate	Tampa Truck Center	\$110,300.00	Build	Options
	Alternate	SBL Freightliner, LLC	\$110,900.00	Build	Options
Southern	Primary	SBL Freightliner, LLC	\$109,200.00	Build	Options
	Alternate	Orlando Freightliner	\$110,191.00	Build	Options
	Alternate	Tampa Truck Center	\$110,888.00	Build	Options

Bid Award

Contract: FSA25-VEH23.0, Heavy Trucks and Buses

Group: Cab and Chassis Trucks: 52,000 lbs. GVWR Truck 4x6

Item: 76, International, HV, 615

Description: Refer FSA Base Specifications PDF document.

Model Upgrade/Downgrade:

Zone	Rank	Vendor	Price	Build File	Options File
Western	Primary	Cumberland International Trucks of Florida	\$125,250.00	Build	Options
Northern	Primary	Cumberland International Trucks of Florida	\$124,500.00	Build	Options
Central	Primary	Sun State International Trucks	\$124,428.00	Build	Options
	Alternate	Cumberland International Trucks of Florida	\$124,500.00	Build	Options
Southern	Primary	Rechtien International Trucks	\$124,650.00	Build	Options

Bid Award

Contract: FSA25-VEH23.0, Heavy Trucks and Buses

Group: Cab and Chassis Trucks: 52,000 lbs. GVWR Truck 4x6

Item: 77, International, HX, 620F

Description: Refer FSA Base Specifications PDF document.

Model Upgrade/Downgrade:

Zone	Rank	Vendor	Price	Build File	Options File
Western	Primary	Cumberland International Trucks of Florida	\$137,550.00	Build	Options
Northern	Primary	Cumberland International Trucks of Florida	\$136,800.00	Build	Options
Central	Primary	Sun State International Trucks	\$136,697.00	Build	
	Alternate	Cumberland International Trucks of Florida	\$136,800.00	Build	Options
Southern	Primary	Rechtien International Trucks	\$136,990.00	Build	Options

Bid Award

Contract: FSA25-VEH23.0, Heavy Trucks and Buses

Group: Cab and Chassis Trucks: 52,000 lbs. GVWR Truck 4x6

Item: 79, Kenworth, T880, T880

Description: Refer FSA Base Specifications PDF document.

Model Upgrade/Downgrade:

Zone	Rank	Vendor	Price	Build File	Options File
Western					
Northern	Primary	Florida Kenworth, LLC	\$137,984.00	Build	Options
	Alternate	Kenworth of Jacksonville	\$141,410.00	Build	Options
Central	Primary	Florida Kenworth, LLC	\$132,984.00	Build	Options
	Alternate	All Roads Kenworth, LLC.	\$138,190.00	Build	Options
Southern	Primary	Florida Kenworth, LLC	\$132,984.00	Build	Options
	Alternate	All Roads Kenworth, LLC.	\$138,190.00	Build	Options

Bid Award

Contract: FSA25-VEH23.0, Heavy Trucks and Buses

Group: Cab and Chassis Trucks: 52,000 lbs. GVWR Truck 4x6

Item: 80, Mack, AP or G Series, AP or G Series

Description: Refer FSA Base Specifications PDF document.

Model Upgrade/Downgrade:

Zone	Rank	Vendor	Price	Build File	Options File
Western	Primary	Nextran Truck Centers	\$151,453.00	Build	Options
Northern	Primary	Nextran Truck Centers	\$151,453.00	Build	Options
Central	Primary	Nextran Truck Centers	\$151,453.00	Build	Options
Southern	Primary	Nextran Truck Centers	\$151,453.00	Build	Options

Bid Award

Contract: FSA25-VEH23.0, Heavy Trucks and Buses

Group: Cab and Chassis Trucks: 52,000 lbs. GVWR Truck 4x6

Item: 81, Peterbilt, 5671, 5671

Description: Refer FSA Base Specifications PDF document.

Model Upgrade/Downgrade:

Zone	Rank	Vendor	Price	Build File	Options File
Western	Primary	Rush Truck Centers of Florida, Inc.	\$150,014.00	Build	Options
Northern	Primary	Rush Truck Centers of Florida, Inc.	\$150,014.00	Build	Options
Central	Primary	Rush Truck Centers of Florida, Inc.	\$150,014.00	Build	Options
Southern	Primary	The Peterbilt Store South Florida LLC	\$150,755.00	Build	Options

Bid Award**Contract:** FSA25-VEH23.0, Heavy Trucks and Buses**Group:** Cab and Chassis Trucks: 52,000 lbs. GVWR Truck 4x6**Item:** 82, Volvo, V Series, V Series**Description:** Refer FSA Base Specifications PDF document.**Model Upgrade/Downgrade:**

Zone	Rank	Vendor	Price	Build File	Options File
Western	Primary	TRUCKMAX, INC.	\$117,614.00	Build	Options
	Alternate	Nextran Truck Centers	\$137,554.00	Build	Options
Northern	Primary	Nextran Truck Centers	\$137,554.00	Build	Options
Central	Primary	TRUCKMAX, INC.	\$117,614.00	Build	Options
	Alternate	Nextran Truck Centers	\$137,554.00	Build	Options
Southern	Primary	TRUCKMAX, INC.	\$117,614.00	Build	Options
	Alternate	Nextran Truck Centers	\$137,554.00	Build	Options

Bid Award

Contract: FSA25-VEH23.0, Heavy Trucks and Buses

Group: Cab and Chassis Trucks: 52,000 lbs. GVWR Truck 4x6

Item: 83, Western Star, 49X, 49X

Description: Refer FSA Base Specifications PDF document.

Model Upgrade/Downgrade:

Zone	Rank	Vendor	Price	Build File	Options File
Western	Primary	Tampa Truck Center	\$133,855.00	Build	Options
	Alternate	Orlando Freightliner	\$134,900.00	Build	Options
	Alternate	SBL Freightliner, LLC	\$140,950.00	Build	Options
Northern	Primary	Tampa Truck Center	\$134,400.00	Build	Options
	Alternate	Orlando Freightliner	\$134,900.00	Build	Options
	Alternate	SBL Freightliner, LLC	\$140,950.00	Build	Options
Central	Primary	Orlando Freightliner	\$133,791.00	Build	Options
	Alternate	Tampa Truck Center	\$134,400.00	Build	Options
	Alternate	SBL Freightliner, LLC	\$139,950.00	Build	Options
Southern	Primary	Orlando Freightliner	\$134,900.00	Build	Options
	Alternate	SBL Freightliner, LLC	\$134,950.00	Build	Options
	Alternate	Tampa Truck Center	\$135,688.00	Build	Options

Bid Award

Contract: FSA25-VEH23.0, Heavy Trucks and Buses

Group: Refuse Truck Electric: 60,000 lbs. GVWR 4x6 (cab and chassis only)

Item: 84, Battle Motors, Raider EV, Raider EV

Description: Refer FSA Base Specifications PDF document.

Model Upgrade/Downgrade:

Zone	Rank	Vendor	Price	Build File	Options File
Western	Primary	Container Systems & Equipment Co., Inc.	\$460,513.00	Build	Options
Northern	Primary	Container Systems & Equipment Co., Inc.	\$460,513.00	Build	Options
Central	Primary	Container Systems & Equipment Co., Inc.	\$460,513.00	Build	Options
Southern	Primary	Container Systems & Equipment Co., Inc.	\$460,513.00	Build	Options

Bid Award

Contract: FSA25-VEH23.0, Heavy Trucks and Buses

Group: Refuse Truck Electric: 60,000 lbs. GVWR 4x6 (cab and chassis only)

Item: 85, Kenworth, L770E, L770E

Description: Refer FSA Base Specifications PDF document.

Model Upgrade/Downgrade:

Zone	Rank	Vendor	Price	Build File	Options File
Western					
Northern	Primary	Florida Kenworth, LLC	\$448,625.00	Build	Options
	Alternate	Kenworth of Jacksonville	\$475,550.00	Build	Options
Central	Primary	Florida Kenworth, LLC	\$443,625.00	Build	Options
	Alternate	All Roads Kenworth, LLC.	\$534,360.00	Build	Options
Southern	Primary	Florida Kenworth, LLC	\$443,625.00	Build	Options
	Alternate	All Roads Kenworth, LLC.	\$534,360.00	Build	Options

Bid Award

Contract: FSA25-VEH23.0, Heavy Trucks and Buses

Group: Refuse Truck Electric: 60,000 lbs. GVWR 4x6 (cab and chassis only)

Item: 86, Mack, Mack LR Electric, Lre

Description: Refer FSA Base Specifications PDF document.

Model Upgrade/Downgrade:

Zone	Rank	Vendor	Price	Build File	Options File
Western	Primary	Nextran Truck Centers	\$471,351.00	Build	Options
Northern	Primary	Nextran Truck Centers	\$471,351.00	Build	Options
Central	Primary	Nextran Truck Centers	\$471,351.00	Build	Options
Southern	Primary	Nextran Truck Centers	\$471,351.00	Build	Options

Bid Award

Contract: FSA25-VEH23.0, Heavy Trucks and Buses

Group: Refuse Truck Electric: 60,000 lbs. GVWR 4x6 (cab and chassis only)

Item: 87, Peterbilt, 520EV, 520EV

Description: Refer FSA Base Specifications PDF document.

Model Upgrade/Downgrade:

Zone	Rank	Vendor	Price	Build File	Options File
Western	Primary	Rush Truck Centers of Florida, Inc.	\$475,682.00	Build	Options
Northern	Primary	Rush Truck Centers of Florida, Inc.	\$475,682.00	Build	Options
Central	Primary	Rush Truck Centers of Florida, Inc.	\$475,682.00	Build	Options
Southern	Primary	The Peterbilt Store South Florida LLC	\$475,451.00	Build	Options

Bid Award

Contract: FSA25-VEH23.0, Heavy Trucks and Buses

Group: Refuse Truck: 60,000 lbs. GVWR 4x6 (cab and chassis only)

Item: 88, Autocar, ACX64, ACX64

Description: Refer FSA Base Specifications PDF document.

Model Upgrade/Downgrade:

Zone	Rank	Vendor	Price	Build File	Options File
Western	Primary	Bachrodt FT, LLC dba Palmetto Ford of Miami	\$213,989.00	Build	Options
Northern	Primary	Bachrodt FT, LLC dba Palmetto Ford of Miami	\$211,989.00	Build	Options
	Alternate	Florida Kenworth, LLC	\$214,787.00	Build	Options
Central	Primary	Florida Kenworth, LLC	\$209,787.00	Build	Options
Southern	Primary	Bachrodt FT, LLC dba Palmetto Ford of Miami	\$205,989.00	Build	Options
	Alternate	Florida Kenworth, LLC	\$209,787.00	Build	Options

Bid Award

Contract: FSA25-VEH23.0, Heavy Trucks and Buses

Group: Refuse Truck: 60,000 lbs. GVWR 4x6 (cab and chassis only)

Item: 89, Battle Motors, Raider, Raider

Description: Refer FSA Base Specifications PDF document.

Model Upgrade/Downgrade:

Zone	Rank	Vendor	Price	Build File	Options File
Western	Primary	RDK Assets Inc	\$198,789.00	Build	Options
	Alternate	Container Systems & Equipment Co., Inc.	\$209,892.00	Build	Options
Northern	Primary	RDK Assets Inc	\$198,789.00	Build	Options
	Alternate	Container Systems & Equipment Co., Inc.	\$209,892.00	Build	Options
Central	Primary	RDK Assets Inc	\$198,789.00	Build	Options
	Alternate	Container Systems & Equipment Co., Inc.	\$209,892.00	Build	Options
Southern	Primary	RDK Assets Inc	\$198,789.00	Build	Options
	Alternate	Container Systems & Equipment Co., Inc.	\$209,892.00	Build	Options

Bid Award

Contract: FSA25-VEH23.0, Heavy Trucks and Buses

Group: Refuse Truck: 60,000 lbs. GVWR 4x6 (cab and chassis only)

Item: 90, Kenworth, L770, L770

Description: Refer FSA Base Specifications PDF document.

Model Upgrade/Downgrade:

Zone	Rank	Vendor	Price	Build File	Options File
Western					
Northern	Primary	Kenworth of Jacksonville	\$195,251.00	Build	Options
	Alternate	Florida Kenworth, LLC	\$208,351.00	Build	Options
Central	Primary	All Roads Kenworth, LLC.	\$194,194.00	Build	Options
	Alternate	Florida Kenworth, LLC	\$203,351.00	Build	Options
Southern	Primary	All Roads Kenworth, LLC.	\$194,194.00	Build	Options
	Alternate	Florida Kenworth, LLC	\$203,351.00	Build	Options

Bid Award

Contract: FSA25-VEH23.0, Heavy Trucks and Buses

Group: Refuse Truck: 60,000 lbs. GVWR 4x6 (cab and chassis only)

Item: 91, Mack, TE Series, TE Series

Description: Refer FSA Base Specifications PDF document.

Model Upgrade/Downgrade:

Zone	Rank	Vendor	Price	Build File	Options File
Western	Primary	Nextran Truck Centers	\$196,167.00	Build	Options
Northern	Primary	Nextran Truck Centers	\$196,167.00	Build	Options
Central	Primary	Nextran Truck Centers	\$196,167.00	Build	Options
Southern	Primary	Nextran Truck Centers	\$196,167.00	Build	Options

Bid Award

Contract: FSA25-VEH23.0, Heavy Trucks and Buses

Group: Refuse Truck: 60,000 lbs. GVWR 4x6 (cab and chassis only)

Item: 92, Peterbilt, 520, 520

Description: Refer FSA Base Specifications PDF document.

Model Upgrade/Downgrade:

Zone	Rank	Vendor	Price	Build File	Options File
Western	Primary	Rush Truck Centers of Florida, Inc.	\$204,510.00	Build	Options
Northern	Primary	Rush Truck Centers of Florida, Inc.	\$204,510.00	Build	Options
Central	Primary	Rush Truck Centers of Florida, Inc.	\$204,510.00	Build	Options
Southern	Primary	The Peterbilt Store South Florida LLC	\$209,749.00	Build	Options

Bid Award

Contract: FSA25-VEH23.0, Heavy Trucks and Buses

Group: Refuse Truck: Compact 9.5 Cubic Yds. Self-Loading Refuse Truck

Item: 93, Broyhill, TD3.6, TD3.6

Description: Refer FSA Base Specifications PDF document.

Model Upgrade/Downgrade:

Zone	Rank	Vendor	Price	Build File	Options File
Western	Primary	Broyhill Equipment LLC	\$272,645.00	Build	Options
Northern	Primary	Broyhill Equipment LLC	\$272,645.00	Build	Options
Central	Primary	Broyhill Equipment LLC	\$272,645.00	Build	Options
Southern	Primary	Broyhill Equipment LLC	\$272,645.00	Build	Options

Bid Award

Contract: FSA25-VEH23.0, Heavy Trucks and Buses

Group: Spray Truck: 19,500 lbs. GVWR 4x2, Mounted 1,000 gal ROW Spray Unit

Item: 94, Chemical Containers, Inc., 1,025 Gallon Right of Way Spray Truck, CCI1025ROW

Description: Refer FSA Base Specifications PDF document.

Model Upgrade/Downgrade:

Zone	Rank	Vendor	Price	Build File	Options File
Western	Primary	BOZARD FORD	\$182,065.00	Build	
Northern	Primary	BOZARD FORD	\$182,065.00	Build	
Central	Primary	BOZARD FORD	\$182,065.00	Build	
Southern	Primary	Rechtien International Trucks	\$147,760.00	Build	Options
	Alternate	The Peterbilt Store South Florida LLC	\$174,000.00	Build	Options
	Alternate	BOZARD FORD	\$182,065.00	Build	

Bid Award

Contract: FSA25-VEH23.0, Heavy Trucks and Buses

Group: Tactical Armored Vehicles

Item: 95, Ford/IAG, Sentinel, ARV

Description: Refer FSA Base Specifications PDF document.

Model Upgrade/Downgrade:

Zone	Rank	Vendor	Price	Build File	Options File
Western	Primary	Duval Ford LLC	\$338,326.00	Build	Options
Northern	Primary	Duval Ford LLC	\$336,926.00	Build	Options
Central	Primary	Duval Ford LLC	\$337,299.00	Build	Options
Southern	Primary	Duval Ford LLC	\$338,552.00	Build	Options

Bid Award**Contract:** FSA25-VEH23.0, Heavy Trucks and Buses**Group:** Tactical Armored Vehicles**Item:** 96, Terradyne, Gurkha MPV, Gurkha MPV**Description:** Refer FSA Base Specifications PDF document.**Model Upgrade/Downgrade:**

Zone	Rank	Vendor	Price	Build File	Options File
Western	Primary	Terradyne Armored Vehicles Inc.	\$245,058.00	Build	Options
Northern	Primary	Terradyne Armored Vehicles Inc.	\$245,058.00	Build	Options
Central	Primary	Terradyne Armored Vehicles Inc.	\$245,553.00	Build	Options
Southern	Primary	Terradyne Armored Vehicles Inc.	\$246,047.00	Build	Options

Bid Award

Contract: FSA25-VEH23.0, Heavy Trucks and Buses

Group: Terminal Tractor

Item: 98, Capacity, TJ, 5000

Description: Refer FSA Base Specifications PDF document.

Model Upgrade/Downgrade:

Zone	Rank	Vendor	Price	Build File	Options File
Western	Primary	Cumberland International Trucks of Florida	\$137,500.00	Build	Options
Northern	Primary	Cumberland International Trucks of Florida	\$137,500.00	Build	Options
Central	Primary	Cumberland International Trucks of Florida	\$137,500.00	Build	Options
Southern	Primary	Cumberland International Trucks of Florida	\$137,500.00	Build	Options

Bid Award**Contract:** FSA25-VEH23.0, Heavy Trucks and Buses**Group:** Terminal Tractor**Item:** 99, Kalmar Ottawa, T2, 71056**Description:** Refer FSA Base Specifications PDF document.**Model Upgrade/Downgrade:**

Zone	Rank	Vendor	Price	Build File	Options File
Western	Primary	Ottawa Trucks Center Inc.	\$139,329.00	Build	Options
	Alternate	Kenworth of Jacksonville	\$144,675.00	Build	Options
Northern	Primary	Ottawa Trucks Center Inc.	\$139,329.00	Build	Options
	Alternate	Kenworth of Jacksonville	\$144,425.00	Build	Options
Central	Primary	Ottawa Trucks Center Inc.	\$139,329.00	Build	Options
	Alternate	Kenworth of Jacksonville	\$144,775.00	Build	Options
Southern	Primary	Ottawa Trucks Center Inc.	\$139,329.00	Build	Options
	Alternate	Kenworth of Jacksonville	\$144,975.00	Build	Options

Bid Award

Contract: FSA25-VEH23.0, Heavy Trucks and Buses

Group: Terminal Tractor

Item: 100, Kalmar Ottawa, T2 4x2 Offroad, 71055

Description: Refer FSA Base Specifications PDF document.

Model Upgrade/Downgrade:

Zone	Rank	Vendor	Price	Build File	Options File
Western	Primary	Ottawa Trucks Center Inc.	\$137,387.00	Build	Options
	Alternate	Kenworth of Jacksonville	\$142,295.00	Build	Options
Northern	Primary	Ottawa Trucks Center Inc.	\$137,387.00	Build	Options
	Alternate	Kenworth of Jacksonville	\$142,045.00	Build	Options
Central	Primary	Ottawa Trucks Center Inc.	\$137,387.00	Build	Options
	Alternate	Kenworth of Jacksonville	\$142,395.00	Build	Options
Southern	Primary	Ottawa Trucks Center Inc.	\$137,387.00	Build	Options
	Alternate	Kenworth of Jacksonville	\$142,495.00	Build	Options

Bid Award

Contract: FSA25-VEH23.0, Heavy Trucks and Buses

Group: Terminal Tractor

Item: 101, Tico, Pro-Spotter, Pro-Spotter

Description: Refer FSA Base Specifications PDF document.

Model Upgrade/Downgrade:

Zone	Rank	Vendor	Price	Build File	Options File
Western	Primary	Tampa Truck Center	\$158,242.00	Build	Options
Northern	Primary	Tampa Truck Center	\$158,242.00	Build	Options
Central	Primary	Tampa Truck Center	\$158,242.00	Build	Options
Southern	Primary	Tampa Truck Center	\$158,242.00	Build	Options

Bid Award

Contract: FSA25-VEH23.0, Heavy Trucks and Buses

Group: Utility Truck: 33,000 lbs. GVWR 4x4, Digger Derrick

Item: 102, Altec, DM47, DM47

Description: Refer FSA Base Specifications PDF document.

Model Upgrade/Downgrade:

Zone	Rank	Vendor	Price	Build File	Options File
Western	Primary	Altec Industries, Inc.	\$332,500.00	Build	Options
Northern	Primary	Altec Industries, Inc.	\$332,500.00	Build	Options
Central	Primary	Altec Industries, Inc.	\$332,500.00	Build	Options
Southern	Primary	Altec Industries, Inc.	\$332,500.00	Build	Options

Bid Award

Contract: FSA25-VEH23.0, Heavy Trucks and Buses

Group: Utility Truck: 33,000 lbs. GVWR 4x4, Digger Derrick

Item: 103, Terex, Commander 4047, Commander 4047

Description: Refer FSA Base Specifications PDF document.

Model Upgrade/Downgrade:

Zone	Rank	Vendor	Price	Build File	Options File
Western	Primary	Ring Power Corporation	\$312,355.00	Build	
Northern	Primary	Ring Power Corporation	\$312,355.00	Build	
Central	Primary	Ring Power Corporation	\$312,355.00	Build	
Southern	Primary	Ring Power Corporation	\$312,355.00	Build	

Bid Award

Contract: FSA25-VEH23.0, Heavy Trucks and Buses

Group: Utility Truck: 33,000 lbs. GVWR 4x4, Mounted Aerial Device

Item: 104, Altec, AA55, AA55

Description: Refer FSA Base Specifications PDF document.

Model Upgrade/Downgrade:

Zone	Rank	Vendor	Price	Build File	Options File
Western	Primary	Altec Industries, Inc.	\$295,491.00	Build	Options
Northern	Primary	Altec Industries, Inc.	\$295,491.00	Build	Options
Central	Primary	Altec Industries, Inc.	\$295,491.00	Build	Options
Southern	Primary	Altec Industries, Inc.	\$295,491.00	Build	Options

Bid Award

Contract: FSA25-VEH23.0, Heavy Trucks and Buses

Group: Utility Truck: 33,000 lbs. GVWR 4x4, Mounted Aerial Device

Item: 105, Terex, TC55 Optima, TC55 Optima

Description: Refer FSA Base Specifications PDF document.

Model Upgrade/Downgrade:

Zone	Rank	Vendor	Price	Build File	Options File
Western	Primary	Ring Power Corporation	\$274,718.00	Build	
Northern	Primary	Ring Power Corporation	\$274,718.00	Build	
Central	Primary	Ring Power Corporation	\$274,718.00	Build	
Southern	Primary	Ring Power Corporation	\$274,718.00	Build	

FSA Cooperative Purchasing Program



**FSA25-VEH23.0: Heavy Trucks and Buses
How to Order**

How to Purchase



FSA Cooperative Purchasing Program



FSA25-VEH23.0: Heavy Trucks and Buses Terms and Conditions

Florida Sheriffs Association
Cooperative Purchasing Program
Contract Terms and Conditions

Table of Contents

1.0 GENERAL CONDITIONS	5
1.01 BID CORRESPONDENCE.....	5
1.02 PURPOSE	5
1.03 TERM OF CONTRACT	5
1.04 JURISDICTION	5
1.05 SHERIFF AS COUNTY CONSTITUTIONAL OFFICER	5
1.06 FUNDING	6
1.07 CURRENCY	6
1.08 GENERAL DEFINITIONS.....	6
1.09 ELIGIBLE PURCHASERS OF CONTRACT	8
1.10 LEGAL REQUIREMENTS	8
1.11 PATENTS & ROYALTIES.....	9
1.12 FEDERAL AND STATE STANDARDS	9
1.13 UNDERWRITERS’ LABORATORIES	9
1.14 AMERICANS WITH DISABILITIES ACT	9
1.15 REASONABLE ACCOMMODATION	9
1.16 DISADVANTAGED BUSINESSES.....	9
1.17 ANTI-DISCRIMINATION, E-VERIFY, AND ANTI-HUMAN TRAFFICKING REQUIREMENTS 10	
1.18 BEST COMMERCIAL PRACTICES	11
1.19 PUBLIC ENTITY CRIMES (“PEC”) AND SCRUTINIZED COMPANIES STATEMENTS	11
1.20 TAX EXEMPTION.....	11
1.21 ORDER OF PRECEDENCE IN THE EVENT OF CONFLICT	11
1.22 COMMUNICATIONS	12
1.23 CLARIFICATION AND ADDENDA	12
1.24 SIGNED BID CONSIDERED AN OFFER	12
1.25 ASSIGNMENT OF CONTRACT	13
1.26 TERMINATION OF PRODUCT LINE.....	13
1.27 DEMONSTRATION OF COMPETENCY	13

Florida Sheriffs Association
Cooperative Purchasing Program
Contract Terms and Conditions

1.28	VENDOR ABILITY TO PERFORM.....	13
1.29	FINANCIAL RESPONSIBILITY	14
1.30	QUALITY AND SAFETY	14
1.31	NONCONFORMANCE	14
1.32	GRATUITIES	15
1.33	TIE BIDS	15
1.34	RIGHT TO AUDIT.....	15
1.35	LICENSES AND PERMITS.....	16
1.36	PERFORMANCE BONDS.....	16
1.37	ELIMINATION FROM CONSIDERATION	16
1.38	INDEPENDENT PREPARATION.....	16
1.39	DEFAULT.....	17
1.40	PROTESTS AND ARBITRATION.....	17
1.41	NONPERFORMANCE	18
1.42	SEVERABILITY	19
1.43	TERMINATION FOR CAUSE.....	19
1.44	TERMINATION WITHOUT CAUSE	19
1.45	CONTRACT ADVERTISEMENT AND USE OF FSA LOGO.....	19
2.0	BIDDER INSTRUCTIONS.....	21
2.01	QUALIFICATION.....	21
2.02	LICENSING AND FACILITIES	21
2.03	INSURANCE AND INDEMNIFICATION.....	21
2.04	SPECIFICATIONS	23
2.05	SEALED BIDS.....	24
2.06	MISTAKES	24
2.07	EXCEPTIONS	24
2.08	EQUIVALENTS.....	24
2.09	MANDATORY PRE-BID MEETING	24
2.10	PRICES QUOTED	25
2.11	OPTION PRICING	25
2.12	BID SUBMISSION	26

Florida Sheriffs Association
Cooperative Purchasing Program
Contract Terms and Conditions

2.13	ZONE BIDDING	27
2.14	EXECUTION OF BID.....	27
2.15	MODIFICATION OR WITHDRAWALS OF BIDS.....	27
2.16	LATE BIDS	27
2.17	BID OPENING.....	27
2.18	DETERMINATION OF RESPONSIVENESS.....	28
2.19	RESPONSIBLE BIDDER CRITERIA.....	28
2.20	BASIS FOR AWARD	28
2.21	BID TABULATIONS.....	29
2.22	MINOR IRREGULARITIES/RIGHT TO REJECT	29
2.25	CONE OF SILENCE.....	29
3.0	CONTRACT CONDITIONS	30
3.01	GENERAL REQUIREMENTS	30
3.02	STATEMENT OF AUTHORITY	30
3.03	VENDOR CONTACT INFORMATION.....	30
3.04	ADDITIONS OR DELETIONS.....	30
3.05	CONTRACT EXTENSION	30
3.06	PRICE ADJUSTMENT	31
3.07	CONDITIONS.....	31
3.08	PRODUCTION CUTOFF	31
3.09	FACILITIES.....	32
3.10	CAB AND CHASSIS PURCHASES	32
3.11	FACTORY-INSTALLED OPTIONS	32
3.12	VENDOR-INSTALLED OPTIONS	32
3.13	NON-SCHEDULED OPTIONS	32
3.14	FORCE MAJEURE	33
3.15	PARTS	33
3.16	PURCHASE ORDERS.....	33
3.17	REGISTRATION, TAG, AND TITLE	34
3.18	DELIVERY	34
3.19	INSPECTION AND ACCEPTANCE	35

Florida Sheriffs Association
Cooperative Purchasing Program
Contract Terms and Conditions

3.20	INVOICING AND PAYMENTS.....	35
3.23	WARRANTY.....	35
3.24	QUARTERLY REPORTS	35
3.25	ADMINISTRATIVE FEE.....	36
3.26	LIQUIDATED DAMAGES.....	37
	Appendix A: Zone Map.....	38
	Appendix B. Bid Calendar.....	39
	Appendix C: ACH Payments	40
	Appendix D: Federal Clauses.....	41

Florida Sheriffs Association
Cooperative Purchasing Program
Contract Terms and Conditions

1.0 GENERAL CONDITIONS

1.01 BID CORRESPONDENCE

All correspondence regarding this bid should be directed to the Florida Sheriffs Association (“FSA”). Please be sure to reference the bid number and title and provide your contact information. Communication for this Invitation to Bid should be identified by contract number and title and directed to:

Florida Sheriffs Association
Attn: Cooperative Purchasing Program Coordinator
2617 Mahan Drive
Tallahassee, FL 32308
E-mail: CPP@flsheriffs.org

1.02 PURPOSE

The Florida Sheriffs Association invites interested bidders, including manufacturers and dealers or authorized representatives (each a “Bidder” and together, “Bidders”), to submit responses in accordance with this solicitation document for Bid FSA25-VEH23.0 Heavy Trucks and Buses. The FSA Cooperative Purchasing Program will conduct the solicitation process and administer the resulting contract. The purpose of this bid is to establish contracts with manufacturers and/or manufacturers’ authorized dealers for contract terms specified under Section 1.03 for the purchase of on a “no trade-in basis.”

1.03 TERM OF CONTRACT

The term for Contract FSA25-VEH23.0 Heavy Trucks and Buses (“Contract” or “Agreement”) shall remain in effect for two years from date of Contract execution by the FSA, and may be extended by mutual agreement, at the sole option and discretion of the FSA. The initial term of this Contract begins October 1, 2025, and ends September 30, 2027.

Contract extensions will only be executed when the FSA determines, based on then-existing conditions, that it is in the best interest of the FSA and the purchasers to do so.

1.04 JURISDICTION

This Agreement and the provisions contained herein shall be governed by and interpreted and construed in accordance with the laws of the State of Florida. Each party consents that the venue for any litigation arising out of or related to this Agreement shall lie in the appropriate court in and for Leon County, Florida.

1.05 SHERIFF AS COUNTY CONSTITUTIONAL OFFICER

The Offices of the Sheriff in the State of Florida are constitutional offices of the State of Florida. Each has the authority either individually or collectively to execute contracts for all goods and services for the proper conduct of that office. Section 30.53, *Florida Statutes*, exempts the sheriffs’ offices from the provisions of the Florida Statutes that would otherwise require sealed and competitive bidding procedures “concerning the purchase and procurement of supplies and equipment, selection of personnel, and the hiring, firing, and setting of salaries of such personnel”.

Florida Sheriffs Association
Cooperative Purchasing Program
Contract Terms and Conditions

The Offices of the Sheriff are not required by law to accept the lowest priced proposal and may reject any or all of the proposals without recourse. Bidders are solely responsible for their own bid preparation costs and nothing in this solicitation in any way obligates the participating sheriffs' offices for any payment for any activity or costs incurred by any Bidder in responding to this solicitation.

1.06 FUNDING

In the case of certain purchasers, including state agencies, funds expended for the purposes of a contract must be appropriated by the Florida Legislature, the individual purchaser or the purchaser's appropriating authority for each fiscal year included within the contract period. For such purchasers, their performances and obligations to pay for products or services under any resulting contract or Purchase Order, including this Contract, are contingent upon such an annual appropriation by the Legislature, individual purchaser or by the appropriating authority. Therefore, any contract or Purchase Order, including this Contract, with such a purchaser shall automatically terminate without penalty or termination costs in the event of non-appropriation.

1.07 CURRENCY

All transaction amounts, bids, quotes, provisions, payments or any part of this Contract relating to currency are to be made in United States Dollars.

1.08 GENERAL DEFINITIONS

The terms used in this Contract are defined as the following:

- A. Bidder: A business or enterprise that submits a formal bid to the Florida Sheriffs Association Cooperative Purchasing Program in accordance with these Terms and Conditions. A bidder, that is not the Manufacturer, must be authorized by the Manufacturer to market and sell an item for which they are bidding.
- B. Bid System: The online forum used for the submission of bids and review of bid results for the specifications connected to this Invitation to Bid. VendorLink is the software used for this bid.
- C. Build Sheet: A document from the Bidder that confirms that the item submitted meets or exceeds the FSA Base Specifications. Build Sheets include, but are not limited to, the factory options list and door data plate information for vehicles that include details such as engine size and transmission, paint codes, production date, axle code, etc.
- D. Dealer: An enterprise authorized by the Manufacturer to market, sell, provide, and service the items for the Florida Sheriffs Association Cooperative Purchasing Program. Dealers may be Vendor-owned and controlled, in whole or in part, or independently owned and controlled.
- E. End User: A term used to distinguish the person who ultimately uses or is intended to use a product or for whom a product is designed for use.
- F. Factory: Refers to the Manufacturer produced products.
- G. Fleet Advisory Committee ("Committee"): An employee of a sheriff's office or other local governmental agency, or person who FSA CPP identifies as a subject matter expert who assists with the development of bid specifications and evaluation of bid responses. The Committee makes recommendations to the FSA CPP but is not responsible for final awards.

Florida Sheriffs Association
Cooperative Purchasing Program
Contract Terms and Conditions

- H. Florida Sheriffs Association Cooperative Purchasing Program (“FSA CPP”): The entity that administers the Invitation to Bid and contract administration functions for the resulting contract(s).
- I. FSA Base Specifications: Written descriptions of the minimum requirements for each item or item group developed by the FSA CPP for Bidders to bid on. These item requirements may be unique to FSA CPP and require additional components to the Manufacturer’s standard item.
- J. Invitation to Bid: A competitive solicitation and award process established through the issuance of an invitation to Bidders, vendors, Dealers and Manufacturers to submit a price offer on a specific product to be provided. This term shall include the FSA Base Specifications available to Bidders on the Bid System and references to solicitation documents. The term shall not include requests for proposals, requests for quotes, requests for letters of interest, or purchase orders based on oral or written quotations.
- K. Manufacturer: The original producer or provider of items offered on this Contract.
- L. Manufacturer’s Suggested Retail Price (“MSRP”): The Manufacturer’s recommended retail selling price, list price, published list price, or other usual and customary price that would be paid by the purchaser. The following are acceptable sources of current MSRPs and MSRP Lists for use in submission of the bid solicitation and the resulting contract:
 - a. Manufacturer’s Computer Printouts
 - b. Chrome Systems, Inc.’s PC Carbook Plus and PC Carbook Fleet Edition
 - c. Manufacturer’s Annual U.S. Price Book
 - d. Manufacturer’s official website
- M. Non-Scheduled Option: Any optional new or unused component, feature or configuration that is not included or listed in the FSA Base Specifications or options provided by the Vendor.
- N. Production Cutoff: A date used by Manufacturers to notify vendors and Dealers that the Manufacturer has reached maximum capacity for orders or are discontinuing the production of an item. Vehicle Manufacturers use this term when referring to any given model year for production.
- O. Published List Price: A standard “quantity of one” price currently available to government and educational purchasers, excluding cooperative or volume discounts.
- P. Purchase Order: An official request for order from a purchaser to an awarded Vendor for an item that has been awarded on this Contract. Purchase Orders placed using this Contract formalize the Terms and Conditions of this Contract under which a Vendor furnishes items to a purchaser.
- Q. Purchaser: An entity that seeks to obtain items awarded on this Contract by meeting the eligible user criteria.
- R. Qualifications Packet: This packet containing the required forms, attestations, authorizations, and organizational information needed by Bidders to qualify.
- S. Terms and Conditions: This document, which serves as the governing Invitation to Bid and Contract for the identified FSA CPP Invitation to Bid and resulting contract(s). Standard regulations, processes, procedures, and compliance requirements are identified herein. Bidders complete a Qualifications Packet during the bid process indicating they agree to comply with the Terms and Conditions, and that this will serve as the

Florida Sheriffs Association

Cooperative Purchasing Program

Contract Terms and Conditions

Contract for both parties, should the Bidder(s) receive award. Bidder must respond to the Contract Signature Form affirming acceptance of the Terms and Conditions, which will serve as the Contract for both parties, should the Bidder receive an award.

- T. Third Party Supplier: Businesses external to a Bidder or Vendor that provide products and services which contribute to the overall finished item in this Contract. Third Party Suppliers are contractors and/or subcontractors under the direction and responsibility of the Bidder or Vendor.
- U. Vendor: The Bidder(s) that receive award, who agree to provide the contract items that meet the requirements of this ITB and FSA Base Specifications of the Contract. The Vendor must agree to the Terms and Conditions, which will serve as the governing Contract. If the Vendor is not the Manufacturer, the Vendor must be authorized by the Manufacturer to market, sell, provide, and service all awarded items.
- V. Vendor Installed: A product or service provided by the Vendor or other third party; not the factory.

1.09 ELIGIBLE PURCHASERS OF CONTRACT

Awarded bid contract pricing will be extended and guaranteed to the Florida Sheriffs Association, any unit of local government, political subdivision or agency of the State of Florida ("State"). This includes, but is not limited to counties, municipalities, sheriffs' offices, clerks, property appraisers, tax collectors, supervisors of elections, school boards or districts, water management districts, other special districts, police and fire departments, emergency response units, state universities and colleges, or other state, local or regional government entities within the State of Florida. Eligible purchaser also includes all Eligible Users as defined in Section 60A-1.001(2), *Florida Administrative Code* ("F.A.C.").

All purchasers are bound by applicable Federal and State law, local ordinances, rules and regulations for purchases made under this Contract. Participating agencies cannot guarantee any order other than those ordered by the individual agency.

In addition, awarded bids can be extended and guaranteed to other entities, which can include out-of-state sales, in accordance with Vendors' individual Manufacturers' agreements. Vendors that wish to extend contract pricing to entities other than those defined here are governed by their Manufacturers' agreements and must agree to the Terms and Conditions.

1.10 LEGAL REQUIREMENTS

Federal, State, and local laws, ordinances, rules and regulations, including any applicable motor vehicle dealer laws, that in any manner affect the items covered herein apply to this Contract and all services, work, materials, and supplies provided by Vendor in order to fulfill its obligations under this Contract. Lack of knowledge by the Bidder of applicable legal requirements will in no way be a cause for relief from responsibility.

Bidders have the option to certify that they are willing to accept Purchase Orders funded in whole or in part with Federal funds. By opting in, Bidders certify that they are willing to comply with the requirements outlined in Appendix D upon receipt of a federally funded Purchase Order. This is not a requirement of the Invitation to Bid or Contract. Bidders are not required to opt-in; however, they are required to indicate whether they will opt-in or opt-out of receiving federally funded Purchase Orders. FSA CPP has taken actions to provide and develop information, materials, and resources for Bidders, Vendors and purchasers that will assist in the use of Federal funding with this

Florida Sheriffs Association
Cooperative Purchasing Program
Contract Terms and Conditions

Contract. It is the responsibility of the purchaser to determine compliance for each Vendor, if they wish to use Federal funds for purchase or intend to request reimbursements using Federal funds.

1.11 PATENTS & ROYALTIES

The Vendor, without exception, shall indemnify and hold harmless the Florida Sheriffs Association (“FSA”) and its employees from liability of any nature or kind, including costs and expenses for, or on account of, any copyrighted, patented, or unpatented invention, process, or article manufactured or used in the performance of the Contract, including its use by the FSA or a purchaser.

If the Bidder uses any design, device or materials covered by letters, patent, or copyright, it is mutually understood and agreed, without exception, that the bid prices shall include all royalties or costs in any way arising, directly or indirectly, from the use of such design, device, or materials in any way involved in the work.

1.12 FEDERAL AND STATE STANDARDS

It is the intent of FSA CPP that all specifications herein are in full and complete compliance with all Federal and State of Florida laws, requirements, and regulations applicable to the type and class of commodities and contractual services being provided.

In addition, any applicable Federal or State legal or regulatory requirements that become effective during the term of the Terms and Conditions, regarding the items and services specifications, safety, and environmental requirements shall immediately become a part of the Terms and Conditions. The Vendor shall meet or exceed any such requirements of the laws and regulations. If an apparent conflict exists, the Vendor shall contact the FSA CPP immediately.

1.13 UNDERWRITERS’ LABORATORIES

Unless otherwise stipulated in the bid, all manufactured items and fabricated assemblies shall be Underwriters’ Laboratories, or U.L., listed or re-examination listing where such has been established by U.L. for the item(s) offered and furnished.

1.14 AMERICANS WITH DISABILITIES ACT

To request this material in accessible format, sign language interpreters, information on access for persons with disabilities, or any accommodation to review any document or participate in any FSA sponsored proceeding, please contact FSA Human Resources at (850) 877-2165 five business days in advance to initiate your request. TTY users may also call the Florida Relay Service at 711.

1.15 REASONABLE ACCOMMODATION

In accordance with the Title II of the Americans with Disabilities Act, any person requiring an accommodation because of a disability at the bid opening must contact the FSA Human Resources at (850) 877-2165.

1.16 DISADVANTAGED BUSINESSES

As part of the solicitation process FSA CPP makes information publicly available to potentially qualified entities, and conducts additional outreach to qualified:

Florida Sheriffs Association

Cooperative Purchasing Program

Contract Terms and Conditions

- Small businesses,
- Minority-owned small businesses,
- Women-owned small business enterprises, and
- Disadvantaged business enterprises.

FSA CPP takes necessary affirmative steps to ensure that minority businesses, women's business enterprises, and labor surplus area firms are used, when possible, as recommended by 2 C.F.R. § 200.321. FSA CPP will:

- Evaluate whether small, minority, and women's businesses are potential sources,
- Place those qualified small and minority businesses and women's business enterprises on solicitation lists, and
- Search the Small Business Administration, Minority Business Development Agency, and Labor Surplus Area reports for additional potential sources.

Bidders self-certify in the Qualifications Packet whether they meet the state and federal definitions of a small business, minority-owned small business, women-owned small business enterprise, and disadvantaged business.

1.17 ANTI-DISCRIMINATION, E-VERIFY, AND ANTI-HUMAN TRAFFICKING REQUIREMENTS

The Bidder certifies that they are in compliance as applicable by federal or state law with the non-discrimination clause contained in Section 202, Executive Order 11246, as amended by Executive Order 11375, relative to equal employment opportunity for all persons without regard to race, color, religion, sex or national origin.

The Vendor shall comply with and perform all applicable provisions of Section 448.095, *Florida Statutes*. The Vendor shall register with and use the United States Department of Homeland Security's E-Verify system to verify the work authorization status of all newly hired employees. The FSA CPP, or purchaser, may terminate this Agreement immediately for cause if there is a good faith belief that the Vendor has knowingly violated Section 448.091, *Florida Statutes*.

If the Vendor anticipates entering into agreements with a subcontractor for the services and/or work contemplated under this Agreement, the Vendor will not enter into the subcontractor agreement without first receiving an affidavit from the subcontractor regarding compliance with Section 448.095, *Florida Statutes*, and stating that the subcontractor does not employ, contract with, or subcontract with an unauthorized alien. The Vendor shall maintain a copy of such affidavit for the duration of the agreement and provide a copy to the FSA CPP, or purchaser, upon request.

In the event that the FSA CPP, or purchaser, has a good faith belief that a subcontractor has knowingly violated Section 448.095, *Florida Statutes*, but the Vendor has otherwise complied with its obligations hereunder, the FSA CPP, or purchaser, shall promptly notify the Vendor. The Vendor agrees to immediately terminate the agreement with the subcontractor upon notice from the FSA CPP or purchaser. Further, absent such notification from the FSA CPP or purchaser, the Vendor or any subcontractor who has a good faith belief that a person or entity with which it is contracting has knowingly violated Section 448.09(1), *Florida Statutes*, shall promptly terminate its agreement with such person or entity.

By entering into this Contract, the Vendor represents that no public employer has terminated a contract with the Vendor under Section 448.095(5)(c), *Florida Statutes*, within the year immediately preceding the date of this Contract.

Florida Sheriffs Association
Cooperative Purchasing Program
Contract Terms and Conditions

The Vendor certifies, by acceptance of this Contract, that neither it nor its principals utilize coercion for labor or services as defined in Section 787.06, *Florida Statutes*. The Vendor agrees to execute an affidavit in a form satisfactory to FSA CPP or the purchaser in compliance with Section 787.06(13), *Florida Statutes*.

1.18 BEST COMMERCIAL PRACTICES

The apparent silence or omission of any description from the specifications shall be regarded as meaning that only the best commercial practices, size, and design are to be used. All workmanship is to be first quality. All interpretations of FSA Base Specifications shall be upon the basis of this statement.

1.19 PUBLIC ENTITY CRIMES (“PEC”) AND SCRUTINIZED COMPANIES STATEMENTS

In accordance with the Public Entity Crimes Act, Section 287.133, *Florida Statutes*, a person or affiliate who has been placed on the convicted vendor list, maintained by the State of Florida Department of Management Services following a conviction for public entity crimes, may not submit a bid on a contract to provide any goods or services to a public entity, may not submit a bid on a contract with a public entity for the construction or repair of a public building or public work, may not submit bids on leases of real property to a public entity, may not be awarded or perform work as a vendor, supplier, sub-vendor, or consultant under a contract with a public entity, and may not transact business with any public entity in excess of the threshold amount provided in Section 287.017, *Florida Statutes*, for CATEGORY TWO for a period of 36 months from the date of being placed on the convicted vendor list.

In accordance with Section 287.135, *Florida Statutes*, Bidder certifies that neither it nor any of its officers, directors, executives, partners, shareholders, members, or agents is on the Scrutinized Companies with Activities in Sudan List, the Scrutinized Companies with Activities in the Iran Terrorism Sectors List, or the Scrutinized Companies that Boycott Israel List created pursuant to Sections 215.4725 and 215.473, *Florida Statutes*, and in the event such status changes, Bidder and/or Vendor, if status changes after award, shall immediately notify FSA CPP and/or the purchaser. If Bidder and/or Vendor, if applicable after award, is found to have submitted a false statement, has been placed on the Scrutinized Companies with Activities in Sudan List, the Scrutinized Companies with Activities in the Iran Terrorism Sectors List, or has been engaged in business operations in Cuba or Syria, or is now or in the future on the Scrutinized Companies that Boycott Israel List, or engaged in a boycott of Israel, the FSA CPP may immediately terminate this Contract.

1.20 TAX EXEMPTION

Purchasers making a purchase pursuant to the awarded bid are generally exempt from Federal Excise and State Sales Tax. It is the responsibility of the Vendor to verify that the purchaser is exempt by obtaining the purchaser’s Federal Excise and State Taxes and Use Certificate Number.

The Florida Sheriffs Association is a 501(c)3 organization and is exempt from all Federal Excise and State Taxes. The FSA State Sales Tax and Use Certificate Number is 85-8012646919C-3.

1.21 ORDER OF PRECEDENCE IN THE EVENT OF CONFLICT

In the event of conflict, the conflict may be resolved in the following order of priority (highest to lowest):

- Addenda to Contract Terms and Conditions, if issued
- Contract Conditions
- General Conditions

Florida Sheriffs Association
Cooperative Purchasing Program
Contract Terms and Conditions

- Addenda to FSA Base Specifications, if issued
- FSA Base Specifications
- Bidder Instructions

1.22 COMMUNICATIONS

Communications between a Bidder, lobbyist or consultant and FSA are limited to matters of process or procedure and shall be made in writing to the FSA CPP Staff.

Bidders should not rely on representations, statements, or explanations other than those made in this Invitation to Bid or in any written addendum to this Invitation to Bid, and no oral representations, statements, or explanations shall be deemed to bind the FSA or Eligible Users.

1.23 CLARIFICATION AND ADDENDA

Any questions or clarifications concerning the Invitation to Bid shall be submitted to FSA CPP by e-mail to CPP@flsheriffs.org with the bid title and number referenced on all correspondence. Final questions must be received by the date for Request for Clarification stated on the Bid Calendar. Questions and answers will be posted to the FSA CPP website on the date indicated on the Bid Calendar. Questions received during the cone of silence date listed on the bid calendar will not be addressed, except as provided herein.

Interpretation of the specifications or any solicitation documents will **not** be made to the Bidder verbally, and if any verbal clarifications are provided, they are without legal effect. FSA CPP will make every attempt to e-mail updates to registered Bidders. However, posting to the FSA CPP website or the Bid System constitutes proper notice of addenda.

The FSA CPP shall issue a formal addendum if substantial changes that impact the submission of bids are required. Any such addenda shall be binding on the Bidder and shall become a part of the solicitation document. In the event of conflict with the original specifications, addenda shall govern to the extent specified. Subsequent formal addenda, if any, shall govern over prior formal addenda only to the extent specified. The FSA will not be responsible for any explanation or interpretation made verbally or in writing except those made through the posting of a formal addendum.

The bid submission constitutes acknowledgment of addenda to the FSA Base Specifications. Bids that fail to account for the specification addenda shall be determined to be nonresponsive; however, the FSA CPP may waive this requirement when in its best interest.

After the start of the Contract term, FSA CPP will notify all Vendors of any addenda and will require acknowledgement of the new terms and conditions. If the Vendor does not agree to the new terms and conditions, the Vendor's award can be removed or replaced by another Vendor or qualified responsive bidder.

1.24 SIGNED BID CONSIDERED AN OFFER

The signed bid shall be considered an offer on the part of the Bidder, which offer shall be deemed accepted upon approval by the FSA CPP. The bid submission must be signed by an authorized representative. Submission of a bid in the FSA CPP Bid System constitutes a signed bid for purposes of bid evaluation. An electronic signature may be used and shall have the same force and effect as a written signature.

Florida Sheriffs Association
Cooperative Purchasing Program
Contract Terms and Conditions

1.25 ASSIGNMENT OF CONTRACT

No right or interest in this contract may be assigned, transferred, conveyed, sublet or otherwise disposed of, without prior written consent of the FSA CPP.

If the original Vendor sells or transfers all assets or the entire portion of the assets used to perform this Contract, a successor-in-interest must perform all obligations under this Contract. FSA CPP reserves the right to reject the acquiring entity as Vendor. A change of name agreement will not change the contractual obligations of the Vendor.

In the event a Manufacturer reassigns the product line to an alternate company, the Vendor is required to notify the FSA CPP in writing of the change within 10 business days of the reassignment. If the Vendor is not already an approved FSA CPP Vendor, the alternate company is required to submit a Qualifications Packet to the FSA CPP to become an approved Vendor *prior to* conducting any qualified sales. FSA CPP may approve such assignments of existing or new vendors at its discretion. The Vendor is required to honor the contract pricing and all of the applicable Terms and Conditions throughout the remaining term of the Contract.

1.26 TERMINATION OF PRODUCT LINE

If a Vendor terminates a product line (Manufacturer or brand), the Vendor is required to notify the FSA CPP within 10 business days of the decision not to retain the product line. FSA CPP may remove the terminated products from the Contract. In the event of a termination of a product line (Manufacturer or brand), the purchaser shall compensate the Vendor in accordance with the Contract for all goods delivered by the Vendor prior to termination, net of any costs incurred by the purchaser and FSA as a consequence of the termination.

1.27 DEMONSTRATION OF COMPETENCY

Bidders must be able to demonstrate a good record of performance for a reasonable period of time, and have sufficient financial support, equipment and organization to ensure they can satisfactorily execute the services if awarded a Contract under the Terms and Conditions herein stated.

The terms "equipment" and "organization" as used herein shall be construed to mean a fully equipped and well-established company in line with the best business practices in the industry and as determined by the FSA CPP.

The FSA CPP may consider any evidence available and may require submission of supporting documentation regarding the financial, technical and other qualifications and abilities of a Bidder, including past performance with the FSA CPP, in making the award.

FSA CPP may inspect the Bidder's facility prior to the award of a Contract. Bids will only be considered from firms which are regularly engaged in the business of providing the goods or services described in this Invitation to Bid.

1.28 VENDOR ABILITY TO PERFORM

The FSA CPP may require Bidders to show proof that they have been designated as authorized representatives of a Manufacturer or supplier, which is the actual source of supply. In these instances, the FSA CPP may also require information from the source of supply regarding the quality, packaging and characteristics of the products. Any conflicts between this material information provided by the source of supply and the information contained in the bid submission may render the bid nonresponsive.

Florida Sheriffs Association

Cooperative Purchasing Program

Contract Terms and Conditions

During the Contract term, FSA CPP may review the Vendor's record of performance and may require submission of supporting documentation to ensure that the Vendor is providing sufficient financial support, equipment and organization.

If the FSA CPP determines that the Vendor no longer possesses the financial support, equipment and organization in order to comply with this section, FSA has the authority to immediately terminate the Contract.

By responding to this Invitation to Bid, the Bidder warrants that, to the best of his or her knowledge, there is no pending or threatened action, proceeding, or investigation, or any other legal or financial condition, that would in any way prohibit, restrain, or diminish the Bidder's ability to satisfy the obligations of a resulting contract. The Bidder warrants that neither it nor any affiliate is currently on the convicted vendor list maintained pursuant to Section 287.133, *Florida Statutes*, or on any similar list maintained by any other state or the federal government. The Bidder, by responding to this Invitation to Bid, acknowledges and warrants that, if selected, Bidder (being then considered a "Vendor") shall immediately notify the FSA CPP and purchaser(s) in writing if its ability to perform is compromised in any manner during the term of the Contract.

1.29 FINANCIAL RESPONSIBILITY

Bidder affirms by the submission of the bid and by signature on the Contract Signature Form that the Bidder:

- Has fully read and understands the scope, nature, and quality of work to be performed or the services to be rendered under this Invitation to Bid and has adequate facilities and personnel to fulfill such requirements.
- Accepts the financial responsibility associated with this bid and declares that they have the access to capital (in the form of liquidity or credit lines) in order to meet the financial demands of such award.
- Has assessed the financial responsibility required to serve the Contract as bid, including such details as the obligations to perform all items bid, zones bid, and quantities that could be ordered, as well as timing of payment from purchasers, which can be 45 calendar days from receipt of invoice.

1.30 QUALITY AND SAFETY

All materials used for the manufacture or construction of any supplies, materials or equipment covered by this bid shall be new. The items bid must be new, the latest model, of the best quality, and highest-grade workmanship that meet or exceed federal safety standards.

Items requiring certification should require certification of options in cases where non-certified options could result in the decertification of the original product or warranty. In all cases where options are not certified, the Bidder (or, if after award, the Vendor) must disclose to the end user that the non-certified options are not required to be certified. All options must meet or exceed federal safety standards.

1.31 NONCONFORMANCE

Items may be tested for conformance with specifications. Items delivered that do not conform to specifications may be rejected and returned at the Vendor's expense.

Any violation of these stipulations may also result in:

- Vendor's name being removed from the awarded vendor list.
- FSA and purchasers being advised not to do business with Vendor.

Florida Sheriffs Association
Cooperative Purchasing Program
Contract Terms and Conditions

1.32 GRATUITIES

Bidders shall not offer any gratuities, favors, or anything of monetary value to any official, employee, or agent of the FSA, for the purpose of influencing consideration of this bid. Bidders shall disclose in writing any conflicts of interest to FSA prior to any award, or as soon as practicable after learning of any such conflict, including any contractual or employment relationships with FSA or potential purchasers of Bidder's products or services.

1.33 TIE BIDS

FSA CPP has the right to award multiple Bidders the primary or alternate award in the event of a tie. In the event the FSA CPP desires to break tie bids, and businesses have qualifying drug-free work programs, the award will be made using the following criteria, in order:

- Bidder within the State of Florida; and if none, then,
- Vendors' performance record with purchasers; and if none, then
- Coin Toss.

1.34 RIGHT TO AUDIT

Vendor shall establish and maintain a reasonable accounting system that enables FSA CPP to readily identify Vendor's sales. FSA CPP and its authorized representatives shall have the right to audit and to make copies of all related records pertaining to this Contract, including all government sales and eligible user information, whether kept by or under the control of the Vendor, including, but not limited to those kept by its employees, agents, assignees, successors, sub-vendors, or third-party suppliers in whatever form they may be kept – written or electronic. Such records shall include, but not be limited to:

- Accounting records, including but not limited to Purchase Orders, confirmation of orders or invoices, paid vouchers, cancelled checks, deposit slips, ledgers, and bank statements;
- Written policies and procedures;
- Subcontract files (including proposals of successful and unsuccessful Bidders, bid recaps, etc.);
- Original estimates, quotes, or work sheets;
- Contract amendments and change order files;
- Insurance documents; or
- Memoranda or correspondence.

Vendor shall maintain such records during the term of this Contract and for a period of three (3) years after the completion of this Contract or for such period of time as is required for retaining public records pursuant to Florida law. At the Vendor's expense and upon written notice from FSA CPP, the Vendor shall provide such records for inspection and audit by FSA CPP and its authorized representatives. Such records shall be made available to FSA CPP during normal business hours within three (3) business days of receipt of the written notice. FSA CPP may select the Vendor's place of business or offsite location for the audit. The FSA CPP may also request the Vendor provide requested records via e-mail.

Vendor shall ensure FSA has these rights with Vendor's employees, agents, assignees, successors, and third-party suppliers, and the obligations of these rights shall be explicitly included in any subcontracts or agreements formed between the Vendor and any sub-vendors to the extent that those subcontracts or agreements relate to fulfillment of the Vendor's obligations to FSA or purchaser(s).

Florida Sheriffs Association
Cooperative Purchasing Program
Contract Terms and Conditions

Professional fees, personnel costs and travel costs incurred by FSA under its authority to audit and not addressed elsewhere will be the responsibility of the FSA. However, if the audit identifies underreporting, overpricing or overcharges (of any nature) by the Vendor to FSA or a purchaser in excess of three percent (3%) of the total Contract billings, the Vendor shall reimburse FSA for the total costs of the audit not to exceed \$5,000. If the audit discovers substantive findings related to fraud, misrepresentation, or non-performance, FSA may recoup all the costs of the audit work from the Vendor.

Any adjustments or payments that must be made as a result of any such audit or inspection of the Vendor's invoices or records shall be made within a reasonable amount of time (not to exceed 60 calendar days) from presentation of FSA's findings to Vendor.

FSA has the right to assess damages or seek reimbursements or refunds based on audit results.

1.35 LICENSES AND PERMITS

The Bidder shall obtain and pay for all licenses, permits and inspection fees for this bid submission and any resulting contract. Where Vendors are required to enter or go onto FSA or purchaser property to deliver materials or perform work or services as a result of a bid award, the Vendor will assume the full duty, obligation and expense of obtaining all necessary licenses, permits and insurance.

The Bidder must, by the time of award, be actively registered to do business in the State of Florida on SunBiz.gov.

1.36 PERFORMANCE BONDS

Purchasers may request a performance bond from a Vendor. Performance bonds are recommended with prepayment and will be at the expense of the requesting agency. Purchasers should determine the best practice in comparing performance bond expense against any prior discounts that may be available.

1.37 ELIMINATION FROM CONSIDERATION

This Invitation to Bid shall not be awarded to any person or Bidder who has outstanding debts to the FSA, whether in relation to current or previous bid awards or for other business purposes.

1.38 INDEPENDENT PREPARATION

A Bidder shall not, directly or indirectly, collude, consult, communicate or agree with any other Bidder as to any matter related to the bid each is submitting. Additionally, a Bidder shall not induce any other Bidder to modify, withdraw, submit, or not submit a bid.

Bidders and Vendors who are found to have engaged in these acts will be considered nonresponsive and will be suspended or barred from bid participation. Any contract award resulting from these acts may be terminated for default. Further, any such acts detected by the FSA may be reported to relevant law enforcement and/or prosecutorial agencies.

Bidders may submit multiple bids without violating this provision if the bid submitted is not from the same Manufacturer and product line. Dealers that share the same ownership may submit multiple bids without violating this provision if the Bidders are not in the same region featuring the same Manufacturer and product line.

Florida Sheriffs Association
Cooperative Purchasing Program
Contract Terms and Conditions

1.39 DEFAULT

In case of default on the part of Vendor, the FSA CPP may take necessary steps to otherwise procure the products sought, including but not limited to procuring the products or services from the next highest ranked Bidder or from other sources. A defaulting Vendor may be held liable for costs incurred by the FSA in procuring replacement products.

1.40 PROTESTS AND ARBITRATION

Any person who is adversely affected by the decision or intended decision to award shall file a "Notice of Protest" in writing to the FSA CPP within three (3) business days after the posting of the Intent to Award and shall file a formal written protest within five (5) business days after filing the Notice of Protest. Failure to file both a notice of protest and a formal written protest within the above referenced timelines shall constitute a waiver of proceedings.

The burden is on the party protesting the award of the bid to establish grounds for invalidating the award(s). The formal written protest must state with particularity the facts and law upon which the protest is based. Options are for informational purposes only and will not serve as a basis for protest. Failure to do so will result in a denial of protest. Formal written protest which states with particularity the facts and law upon which the protest is based will be reviewed by FSA legal counsel for legal soundness and validity, and corrective action will be taken as needed contingent upon the validity of such claims. However, any additional time required and costs incurred by the FSA to substantiate a protesting party's claim(s) beyond the normal scope of its legal review due to the vague or inconclusive nature of the protesting party's filing will be reimbursable to the FSA and deducted from the protesting party's bond or security which must accompany their filing.

Any Bidder who files an action protesting a decision or intended decision pertaining to this Contract shall post a bond, cashier's check or money order payable to the Florida Sheriffs Association in the amount equal to ten percent (10%) of the item being protested. The bond, cashier's check or money order must be filed at the time of filing the formal written protest or within the five (5) business day period allowed for filing the formal written protest. FSA CPP will provide the amount required within two (2) business days of the notice of protest received. This bond or security will be conditioned upon the payment of all costs which may be adjudged against the protesting party in a court of law and/or to reimburse the FSA for additional legal expenses incurred and required to substantiate the protesting party's claim(s). Failure to post the bond or security requirement within the time allowed for filing will result in a denial of protest. The filing of the protest shall not stay the implementation of the bid award by the Florida Sheriffs Association.

Should the unsuccessful Bidder(s) decide to appeal the decision of the FSA, they shall file a notice to FSA CPP within three (3) business days of the FSA bid protest decision regarding their intent to request arbitration. A demand for arbitration with the American Arbitration Association's ("AAA") commercial panel under its rules and regulations must be made within ten (10) business days of the FSA bid protest decision. Any person who files for an arbitration with the AAA shall post with the Florida Sheriffs Association at the time of filing the formal written arbitration request, a bond, cashier's check or money order payable to the Florida Sheriffs Association in the amount equal to ten percent of the product line being protested. This amount will be the same amount as the FSA CPP provided at the time of filing the initial protest. Failure to provide written notice to FSA CPP, file a demand for arbitration with the AAA, or failure to post the required bond and security requirement within the specified timelines shall constitute a waiver of arbitration proceedings. By responding to this procurement, the Bidder expressly agrees to the use of mandatory binding arbitration to resolve any appeals of the decision of the FSA, and any claims arising from or in any way relating to the procurement process, and expressly waives any and all rights that it may otherwise have to pursue such claims in any other forum, judicial or otherwise.

Florida Sheriffs Association
Cooperative Purchasing Program
Contract Terms and Conditions

If the party filing for arbitration does not prevail, it shall pay all costs, legal expenses and attorneys' fees of the prevailing party incurred in connection with the arbitration. However, if the filing party prevails, the parties shall share equally the fees and expenses of the arbitration and AAA and each shall bear the cost of their own attorneys' fees. The filing for arbitration shall not stay the implementation of the bid award by the Florida Sheriffs Association.

1.41 NONPERFORMANCE

By virtue of the bid submission, Bidder acknowledges its obligation to sell items in all zones for which it is awarded. Upon award, failure of the Vendor to comply with these requirements may result in the imposition of liquidated damages of up to \$1,000 per item, which amount the Vendor agrees is reasonable, or probation, suspension, termination or a combination thereof from current and future bids at the FSA CPP's discretion.

The Vendor shall at all times during the Contract term remain responsive and responsible. In determining Vendor's responsibility, the FSA CPP shall consider all information or evidence that demonstrates the Vendor's ability or willingness to fully satisfy the requirements of the Terms and Conditions.

Vendors that are not in compliance with any of the provisions of this Contract can be assessed liquidated damages, suspended or terminated from the Contract. The FSA CPP at its sole discretion may remove a noncompliant Vendor from future competitive bid solicitations; or take other actions including suspension from the Contract until compliance issues are resolved, limit current or future vendor participation by items or zones, or other actions as determined by FSA CPP at its sole discretion.

At FSA CPP's discretion, Vendors may be required to develop corrective action plans to address contract compliance. Failure to abide by corrective action plans will result in termination of the Contract and future competitive bid solicitations at the discretion of the FSA CPP.

In situations where there is evidence that the Vendor has engaged in egregious breaches of the Contract with respect to either the FSA CPP and/or the purchaser, the Contract can be terminated immediately and the Vendor will be removed from future solicitations for a period of up to three (3) years, or a permanent ban from the bid process at the sole discretion of FSA CPP.

Specific conditions for termination include, but are not limited to: failure to perform, refusal to accept orders during the Contract term while Manufacturer orders are still being accepted for current model year or the new year if the vehicle is price protected by the factory, charging amounts exceeding MSRP on factory or Vendor installed items and packages, requiring the purchase of additional options over and above the base vehicle as a condition of acceptance of order, providing aftermarket options where factory options are available without the consent of the purchaser, any misrepresentation of optional equipment or service as being factory that fails to meet the definition as described in this document, and any other practice deemed to be inconsistent with the intent of the Contract.

Any Vendor presented with a valid Purchase Order consistent with Vendor bid quotes or other agreed upon terms and pricing is required by this Contract to accept such Purchase Order and deliver the product. Purchase Orders must be fulfilled whether or not the Purchase Order includes options. The Vendor must deliver this product in accordance with the Terms and Conditions – regardless of whether doing so will provide the Vendor with a profit or loss.

Failure to deliver the item may result in the purchaser seeking damages for the difference of cost to issue a new Purchase Order with another Vendor, plus any legal fees and damages that may be incurred in the process to facilitate a completed order. Additionally, FSA CPP may seek damages for nonpayment of administrative fees, to

Florida Sheriffs Association
Cooperative Purchasing Program
Contract Terms and Conditions

which FSA CPP is entitled, according to Section 3.25, and any attorneys' fees incurred in the recovery of these damages.

1.42 SEVERABILITY

In the event any provision of this Contract is held to be unenforceable for any reason, the unenforceability thereof shall not affect the remainder of the Contract, which shall remain in full force and effect and enforceable in accordance with its terms.

1.43 TERMINATION FOR CAUSE

If, through any cause within the reasonable control of the Vendor, it shall fail to fulfill in a timely manner, or otherwise violate any of the terms of this Contract, the FSA shall have the right to terminate the services remaining to be performed. Written notice of the deficiencies shall be given to the Vendor and unless the deficiencies are corrected within ten (10) business days, the Contract may be terminated for cause immediately. The right to exercise the option to terminate for cause shall be in the sole discretion of the FSA, and the failure to exercise such right shall not be deemed to constitute a waiver of this right.

In the event of a termination for cause, the purchaser shall compensate the Vendor in accordance with the Contract for all services performed by the Vendor prior to termination, net of any costs incurred by the purchaser and FSA as a consequence of the default.

Notwithstanding the above, the Vendor shall not be relieved of liability to the FSA for damages sustained by the FSA by virtue of any breach of the Contract by the Vendor, and the FSA may reasonably withhold payments to the Vendor for the purposes of offset until such time as the exact amount of damages due the FSA from the Vendor is determined.

1.44 TERMINATION WITHOUT CAUSE

The FSA can terminate the Contract in whole or part without cause by giving written notice to the Vendor of such termination, which shall become effective thirty (30) calendar days following receipt by Vendor of such notice.

In the event of termination without cause, all finished or unfinished documents and other materials shall be properly delivered to the FSA.

The Vendor shall not furnish any product after it receives the notice of termination, except as necessary to complete the continued portion of the Contract, if any. The Vendor shall not be entitled to recover any lost profits that the Vendor expected to earn on the balance of the Contract or cancellation charges.

Any payments to the Vendor shall be only to the total extent of the purchaser's liability for goods or services delivered prior to the date of notice to terminate the Contract.

1.45 CONTRACT ADVERTISEMENT AND USE OF FSA LOGO

The FSA CPP logo is an official logo of the Florida Sheriffs Association designed to promote the program. The FSA CPP logo may be used by Vendors in accordance with the policy contained in this Section 1.45. Use of the FSA CPP logo is limited to the original version received from the FSA. Modifications are not permitted.

Florida Sheriffs Association
Cooperative Purchasing Program
Contract Terms and Conditions

Methods of use include, but are not limited to:

- Electronic mediums such as websites, digital marketing campaigns, social media and e-mail; or
- Print media such as forms, marketing campaigns, business cards, posters, banners, brochures, flyers and postcards.

Vendors may request use of the FSA CPP logo by contacting cpp@flsheriffs.org, and should include a brief description of how the Vendor intends to use it. The official FSA sheriff's star and wreath logo may not be used without prior written permission.

Florida Sheriffs Association
Cooperative Purchasing Program
Contract Terms and Conditions

2.0 BIDDER INSTRUCTIONS

2.01 QUALIFICATION

Bidders are required to complete the Qualifications Packet as part of the bid submission. A Bidder becomes a qualified bidder if they comply with this section and Section 2.09, Mandatory Pre-Bid Meeting.

Qualifications Packet information required for bid submission include:

- Qualification Form
 - Contact Information
 - Business Profile
 - References
 - Disqualifications & Defaults
- Compliance Attestations
 - E-Verify
 - Anti-Human Trafficking
 - Workers' Compensation
 - Drug-Free Workplace
 - Compliance with Applicable Federal, State, and Local Laws and Ordinances
 - Sunbiz
- Federal Compliance

The Qualifications Packet is located on the Bid System.

2.02 LICENSING AND FACILITIES

Bidders are required to obtain all required licenses, including any applicable motor vehicle dealer licenses, and registrations, and comply with all applicable Federal, State, and local laws and ordinances, including any applicable motor vehicle dealer laws, in order to bid on any motor vehicle.

Bidders must maintain a repair facility within the State of Florida to provide warranty service for the items bid. If Bidders do not have a facility, the Bidder must be able to assist purchasers in obtaining warranty work as authorized by the Manufacturer.

2.03 INSURANCE AND INDEMNIFICATION

Vendor shall maintain, at its sole cost and expense, the insurance coverages required by FSA and purchasers through the duration of this Contract, with limits of liability not less than the following:

- Workers' Compensation Insurance in accordance with the laws of the State of Florida.
- Comprehensive General Liability Insurance covering the Vendor's legal liability for bodily injury and property damage, contractual liability, and completed products and operation, with limits of not less than \$1,000,000 per occurrence and \$2,000,000 aggregate, and covering at least the following hazards:
 - Independent Contractors Coverage for bodily injury and property damage in connection with any subcontractors' operation.
- Automobile Liability Insurance covering the Vendor's legal liability for bodily injury and property damage in limits of not less than \$1,000,000 per occurrence, providing coverage for any accident arising out of or resulting from the operation, maintenance, or use by the Vendor of any owned, non-owned, or hired automobiles, trailers, or other equipment required to be licensed.

Florida Sheriffs Association
Cooperative Purchasing Program
Contract Terms and Conditions

- Garage Keepers Liability Insurance covering the Vendor's legal liability for property damage in limits of not less than \$1,000,000 per occurrence.

It is understood and agreed that all insurance policies of insurance provided by the Vendor are primary coverage and non-contributory with respect to any insurance or self-insurance the FSA or purchasers possess that may apply to a loss resulting from the work performed pursuant to this Contract. All insurance policies issued to cover the insurance requirements herein shall provide full coverage from the first dollar of exposure.

Vendor shall be fully liable for the actions of its agents, officers, employees, contractors, partners, subcontractors, and third party suppliers, performing work under this Contract, and shall fully indemnify and hold harmless the Florida Sheriffs Association ("FSA"), the purchasers, and each of their officers, agents, and employees from suits, actions, damages, and costs of every name and description, including legal counsels' fees and court costs, arising from or relating to negligence, omissions, personal injury or damage to real or personal tangible property alleged to be caused in whole or in part by Vendor, its agents, officers, employees, contractors, partners, subcontractors, and third party suppliers; provided, however, that the Vendor shall not indemnify for that portion of any loss or damages resulting directly from the grossly negligent acts or omissions of the FSA or purchasers or for that portion of any loss or damages proximately caused by intentional wrongful acts or omissions of the FSA or purchasers.

All insurance policies shall be issued by companies authorized to do business under the laws of the State of Florida and these companies must have a rating of B+ or better per the AM Best Rating. At no time shall the Vendor be without insurance in the required amounts. No policy may be changed to provide for less coverage than is required or canceled during the term of this Contract without at least thirty (30) days' written notice to the FSA and/or purchasers, as applicable.

The Vendor must specifically and distinctly assume, and does so assume, all risks of damage or injury to property or persons used or employed on or in connection with the work to be performed by Vendor pursuant to this Contract and of all damage or injury to any person or property wherever located, resulting from any action, omission or operation by the Vendor, its agents, officers, employees, contractors, partners, subcontractors, and third party suppliers, under this Contract or in connection with the work contemplated herein. It is understood and agreed that at all times the Vendor, its agents, officers, employees, contractors, partners, subcontractors, and third party suppliers, are acting as independent contractors to the FSA and/or purchasers, as applicable. Nothing in this Contract shall be interpreted or construed as creating or establishing the relationship of employer and employee between the FSA and/or purchasers and the Vendor or any of its agents, officers, employees, contractors, partners, subcontractors, and third party suppliers, or anyone directly or indirectly employed by the Vendor. The parties acknowledge that the Vendor is not an employee for state or federal tax purposes. The Vendor shall hire and pay all of Vendor's employees, agents, subcontractors or anyone directly or indirectly employed by the Vendor, all of whom at all times being entirely under the Vendor's supervision, direction and control. The Vendor shall be responsible for the means, manner, and methods by which its duties, obligations, and responsibilities under this Contract are met to the satisfaction of the FSA and/or purchasers, as applicable. The Vendor shall be responsible for every part of the work contemplated herein, and for all labor, expertise, materials, tools, appliances and property of every description, used in connection with this Contract.

The Vendor will secure and maintain policies of third-party suppliers performing work or providing services and/or materials to or for Vendor in furtherance of Vendor's performance under this Contract. All third-party supplier insurance policies must be made available to the FSA and/or purchasers upon written request. Compliance by the Vendor and all third-party suppliers with the foregoing requirements as to carrying insurance and furnishing copies of the insurance policies will not relieve the Vendor or any of its third-party suppliers of each of their liabilities and obligations under any section or provisions of this Contract. Vendor must be as fully responsible to the FSA and/or

Florida Sheriffs Association
Cooperative Purchasing Program
Contract Terms and Conditions

purchasers for the acts and omissions of the third-party suppliers and of persons employed by the third-party suppliers as Vendor is for acts and omissions of persons directly employed by the Vendor.

The FSA and/or purchasers may request, and upon such request the Vendor must furnish, proof of insurance, within seven (7) calendar days of receipt of the written request once the contract times have commenced. Should the Vendor fail to provide acceptable evidence of current insurance during the Contract term, the FSA and/or purchasers, as applicable, have the right, but not obligation, to consider the Contract breached and terminate the Contract effective immediately, in the sole discretion of the FSA and/or purchasers, as applicable. If Vendor fails to have secured and maintained the required insurance, the FSA and/or purchasers has the right to consider alternate insurance coverage proffered by the Vendor, but has no obligation to do so.

The FSA and/or purchasers will give the Vendor the opportunity to take over and settle or defend any such action at Vendor's sole expense. As permitted by law and within a reasonable time period, the FSA and/or purchasers will give the Vendor written notice of an action or threatened action. Vendor will not be liable for commercially unreasonable costs, expenses or compromises incurred solely by the FSA, or purchasers, in any legal action without Vendor's prior written consent, which consent shall not be unreasonably withheld, conditioned, or delayed.

The Comprehensive General liability insurance coverage, Automobile liability insurance coverage, and Garage Keeper's liability insurance coverage must extend to and include the following contractual indemnity and hold harmless agreement:

The Vendor hereby agrees to indemnify and hold harmless the FSA, a 501(c)3, its officers, agents, and employees from all claims for bodily injuries and for all damages to property, including tangible and intangible, per the insurance requirement under the specifications including costs of investigation, all expenses of litigation, including reasonable legal counsel fees (including paralegal and other expert and support service fees) and the cost of appeals arising out of any such claims or suits because of any and all acts, omissions or commissions by the Vendor, its agents, officers, employees, contractors, partners, subcontractors, and third party suppliers under the Contract FSA25-VEH23.0 Heavy Trucks and Buses.

The foregoing indemnity agreement must apply to any and all claims and suits other than claims and suits arising out of the sole and exclusive gross negligence of the FSA, its officers, agents, and employees, as determined by a court of competent jurisdiction.

The Vendor will notify the insurance agent without delay of the existence of the Hold Harmless Agreement contained within this Contract and furnish a copy of the Hold Harmless Agreement to the insurance agent and carrier.

The Vendor, at all times during the full duration of work under this Contract, including any extra or additional work approved by and consented to in writing by the parties in connection with this Contract, shall meet the requirements of the foregoing provisions.

2.04 SPECIFICATIONS

All items covered by this Invitation to Bid and any resulting contract, and the specifications shall be the Manufacturer's current basic production model, and shall, as a minimum, be equipped with all standard factory equipment in accordance with the Manufacturer's latest literature unless otherwise noted in the Bid System or FSA Base Specifications.

Florida Sheriffs Association

Cooperative Purchasing Program

Contract Terms and Conditions

The FSA Base Specifications are contained in the FSA CPP Bid System, may be requested from FSA CPP, and are retained within FSA CPP's archive. As part of the bid submission, Bidders will be required to provide confirmation that the item bid meets the FSA Base Specifications. FSA CPP may reject bids that fail to provide confirmation that the item(s) bid meet the FSA Base Specifications.

FSA CPP develops the specifications with subject matter experts and publicly available information. However, FSA CPP does not have access to full details from the Manufacturer and relies on Bidders to assist in this process. Bidders should immediately notify the FSA CPP of any inaccuracies in the specifications. All notifications of inaccuracies must be in writing.

If awarded a contract, Vendor(s) must offer and supply an item that either meets or exceeds all the requirements included in the applicable FSA Base Specifications, unless a purchaser specifically issues a Purchase Order for a base item and option that differs from the FSA Base Specifications. Failure of a Vendor to comply with these provisions will result in Vendor being held responsible for all costs required to bring the item into compliance with the contract specifications.

2.05 SEALED BIDS

For purposes of this solicitation, a sealed bid is considered a bid submitted using the FSA CPP Bid System.

2.06 MISTAKES

Bidders are expected to examine the FSA Base Specifications, delivery schedules, bid prices and all information pertaining to servicing this Contract before submitting a bid. Failure to do so will be at the Bidder's risk.

2.07 EXCEPTIONS

Any requested exceptions, deviations, or contingencies a Bidder may have to the Terms and Conditions must be documented in Bidder's submission. Exceptions to the FSA Base Specifications at the time of the bid submission shall reference the item number, make and model. FSA CPP has the discretion to grant or deny, in whole or in part, the Bidder's requested exception, deviation or contingency to the specifications or Terms and Conditions. Bidder acknowledges that the bid may be disqualified if FSA CPP rejects the proposed exceptions.

2.08 EQUIVALENTS

Prior to the opening of the Bid System, Bidders may request item equivalents. The Bidder must submit the Manufacturer name and model number (or product identifier) of each equivalent requested to FSA CPP. Complete, descriptive, technical literature should demonstrate that the equivalent conforms with FSA Base Specifications. If a bid uses equivalents without prior approval, the bid may be disqualified.

2.09 MANDATORY PRE-BID MEETING

Bidders are required to attend or participate in the **mandatory** Pre-Bid Meeting. The Pre-Bid Meeting is designed for Bidders, the Fleet Advisory Committee, and the FSA CPP to clarify questions on the Terms and Conditions and to confirm all FSA Base Specifications. Questions relating to the items, specifications, the bid process, or award can be asked at the Pre-Bid Meeting. Bidders have the opportunity to suggest technical modifications or corrections before the FSA Base Specifications are finalized.

Florida Sheriffs Association
Cooperative Purchasing Program
Contract Terms and Conditions

FSA CPP reserves the right to grant attendance exceptions to the mandatory Pre-Bid Meeting if the Bidder has requested authorization, agrees in writing to meet all the Terms and Conditions without exception and further waives their right to protest the bid process in its entirety or any portion thereof.

2.10 PRICES QUOTED

Items and options should reflect the most complete price and be below MSRP and, at a minimum, should cover the cost of the item or option bid.

Prices quoted in the bid submission should reflect the final amount the Bidder can expect to receive for payment for the items bid for the duration of the Contract, unless otherwise provided in the Contract. Prices submitted as indicated in the sealed bid are final. Bidders acknowledge that prices quoted will be valid for a period of sixty (60) calendar days from the date of bid opening.

Each item, make, and model must be priced and bid separately. Prices must be inclusive of all the components included in the FSA Base Specification.

Prices bid must include the administrative fee FSA CPP charges to administer the Contract, as outlined in these Terms and Conditions. The administrative fee is three quarters of one percent (.0075).

Prices bid must be at least cost, be Free On Board ("FOB") destination, and must include delivery to the purchaser.

Upon award, the Vendor has the authority to offer additional discounts based on prompt payment, quantity, as well as additional Manufacturer or vendor discounts.

2.11 OPTION PRICING

FSA CPP requests Bidders include most frequently purchased options in the Bid System. Option pricing must include the administrative fee. Bidders must provide a price for each option in addition to a percent below MSRP for factory-installed options or a percent above cost for other options.

The FSA CPP has the discretion to disqualify Bidders if the option pricing is excessive. In order to determine if pricing is excessive, Bidders and, if awarded a contract, Vendors agree to provide documentation to FSA CPP to verify cost at any time during the solicitation process or during the Contract term. This information is for comparison purposes and will not be published.

Options are intended to add or delete equipment or features from the FSA Base Specifications. Options can provide an upgrade or downgrade to a Manufacturer's model, such as a slightly different engine size or horsepower, and should not be made available for purchase separate from the base vehicle or equipment. Options may only provide a downgrade to a Manufacturer's model when specifically requested in a Purchase Order issued in accordance with the Terms and Conditions by a purchaser. Bidders shall NOT use options to create an item that is available as another item bid on this Invitation to Bid.

The use of options to facilitate the sale of an alternate Manufacturer's product which is outside the scope of the FSA Base Specifications will be determined nonresponsive and the bid will be rejected in whole or part by the FSA CPP. Bidders must disclose which options require the purchase of other options or are dependent on another option in their bid submission. Option pricing will include all costs of labor associated with the option and cost of labor should not be listed separately.

Florida Sheriffs Association

Cooperative Purchasing Program

Contract Terms and Conditions

Bidder must use proper Manufacturer codes for factory options. Options available through the factory should be bid as and supplied to purchaser as factory options, unless otherwise requested in writing by the purchaser. Factory package options are permitted under this Contract. Factory package options included in the bid submission must detail what components the package includes.

If the Bidder wishes to offer credit to the purchaser for an option that is standard on the FSA Base Specifications, the Bidder should include the word "Credit" at the beginning of the description field and continue to describe the option being credited. For example, "Credit: one key fob" and enter the price the Bidder will credit the purchaser.

2.12 BID SUBMISSION

Bidders must submit a bid electronically using the Bid System. Bid submissions include a price for each item and option bid in accordance with Sections 2.10, 2.11, 2.12, and 2.13. Each Bidder must submit a Qualifications Packet for each bid. The bid must be received by the date and time specified on the Bid Calendar in Appendix B. Failure to meet all submission requirements by the date indicated on the Bid Calendar will result in rejection of the bid.

Bid System: VendorLink

The Bid System is located at <https://www.myvendorlink.com>. Bidders are encouraged to participate in training provided. Usernames and passwords will be issued to Bidders after registering in the Bid System. Contact VendorLink at support@evendorlink.com if technical issues arise during bid submission.

Prices are to be rounded to the nearest whole dollar. If a Bidder submits bid pricing using cents, the following formula will be applied to round the bid pricing to the nearest whole dollar: \$.01-.49 will be rounded down to the dollar bid (e.g., \$50.49 = \$50) and \$.50-.99 will be rounded to the next dollar (e.g., \$50.50 = \$51).

Bid Submission

To ensure correct bid submittal and formatting, Bidders shall:

- Offer a price for each item bid by zone.
- Upload files as instructed in the Bid System; files requested will be .pdf.
- Follow all instructions outlined in this Invitation to Bid and provide all requested information.

The bid shall include the following documents:

- Executed Qualifications Packet.
- Build sheet for each item bid as a single .pdf.
- Any requested exceptions or equivalents.

Option Upload

An option sheet should be submitted for each item bid. The Bid System will accept option information for each item through a .pdf file upload. Each option sheet should include a header to identify the FSA CPP contract title and number, the Bidder name, item number, make and model. Each option sheet should include:

- Option
- Description
- Manufacturer order code or identifying code
- Price
- Cost plus percent for all items not installed at the factory
- Percent below MSRP for factory installed options

Repair and Replacement Parts Upload - Optional

Florida Sheriffs Association

Cooperative Purchasing Program

Contract Terms and Conditions

If a Vendor chooses to sell repair and replacement parts upon award, a parts pricing sheet should be submitted with the bid. Parts are listed by Vendor and are not tied to items bid. A template is offered in the bid system. Each pricing sheet should include:

- Category
- Description
- MSRP or List Price discount percentage
- Exceptions to discount provided
- Quantity discounts

FSA CPP may ask awarded Vendors to supply one (1) hard copy set of the bid with digital signatures and original compliance forms, prior to the Contract execution. Hard copy bids should not be submitted unless specifically requested by FSA CPP. FSA is not responsible for Bidder's improper use of the Bid System. Exceptions may be granted to Bidders by FSA CPP pursuant this section should any Bid System malfunctions occur.

2.13 ZONE BIDDING

Bidders may bid in one or more geographic zones. Bidders must submit pricing for each zone they wish to be evaluated. The zone map is included in Appendix A. The geographic zones are in place to assist Bidders in estimating costs of delivery, which must be included in the price bid and quoted to the purchaser.

2.14 EXECUTION OF BID

By submitting a response to this Invitation to Bid, the Bidder agrees to the Terms and Conditions and to be bound by such Terms and Conditions if selected for award. The Bidder must respond to the Contract Signature Form with the signature of an authorized representative five (5) days prior to award.. All Terms and Conditions are applicable throughout the term of the awarded contract and are not specific to any given year, make or model.

2.15 MODIFICATION OR WITHDRAWALS OF BIDS

A Bidder may submit a modified bid to replace all or any portion of a previously submitted bid until the due date and time of the bid submission listed in the Bid Calendar. Modifications received after the bid due date and time will not be considered.

Bids can be withdrawn in writing prior to the contract award. If a Bidder must withdraw the bid, the Bidder must contact FSA CPP immediately. Bid withdrawals are handled on a case-by-case basis and can result in a limitation of participation in future bids.

2.16 LATE BIDS

The responsibility for submitting a bid before the due date and time on the Bid Calendar is solely and strictly the responsibility of the Bidder. The FSA is not responsible for delays caused by technical problems, any internet outages or delays incurred by electronic delivery, or any other occurrence. Any reference to time will be based on Eastern Time.

2.17 BID OPENING

Bids shall be opened on the date and time specified on the Bid Calendar. The bid opening may occur at the Florida Sheriffs Association, 2617 Mahan Drive, Tallahassee, Florida, or may be offered online.

Florida Sheriffs Association
Cooperative Purchasing Program
Contract Terms and Conditions

FSA CPP will provide a bid inspection period for Bidders following the bid opening. The date, time and duration will be announced prior to the bid opening.

2.18 DETERMINATION OF RESPONSIVENESS

Determination of responsiveness will take place at the time of bid opening and evaluation. In order to be deemed a responsive bidder, the bid must conform in all material respects to the requirements stated in the Invitation to Bid. As set forth in Section 2.22, FSA CPP reserves the right to waive or allow a Bidder to correct minor irregularities.

2.19 RESPONSIBLE BIDDER CRITERIA

Bids will be evaluated to determine if qualifications and Contract requirements are met. Responses that do not meet all requirements of this Invitation to Bid or fail to provide all required information, documents or materials may be rejected as nonresponsive. The FSA CPP will not request documentation or consider a Bidder's social, political or ideological interests in determining if the Bidder is a responsible bidder. FSA CPP will not give preference to a Bidder based on the Bidder's social, political, or ideological interests.

Bidders whose responses, past performance, or current status do not reflect the capability, integrity, or reliability to fully and in good faith perform the requirements of the Contract may be rejected as non-responsible. In determining a responsible Bidder, the following factors may be considered:

- Adequacy of facilities, staffing, and financial resources;
- Previous experience with FSA contract or other similar government contracts;
- Ability to provide excellent customer service, including on previous FSA contracts; and
- Any other information relevant to the responsibility of a Bidder of which FSA CPP is aware.

In addition to the requirements set forth by these Terms and Conditions, FSA CPP reserves the right to request staffing, performance and financial information from any Bidder during the evaluation process.

FSA CPP reserves the right to determine which responses meet the requirements, specifications, Terms and Conditions of the solicitation, and which Bidders are responsive and responsible.

FSA CPP further reserves the right to limit participation of Bidders who, in FSA CPP's sole discretion, are determined to present responsibility concerns that call into question the Bidder's ability to perform but that do not rise to the level of requiring rejection of the Bidder as non-responsible.

2.20 BASIS FOR AWARD

The FSA CPP shall make award to the qualified, responsive and responsible Bidder(s) who submitted the lowest offer price by item, Manufacturer, and zone. Awards may also be made to subsequent lowest responsive and responsible Bidders by item, Manufacturer, and zone, when determined to be in the best interest of the FSA and the purchaser(s). FSA CPP has the discretion to consider option pricing in making the award and to disqualify Bidders for proposing excessive percent(s) or option pricing.

Awards will not be given to any parties listed on the government wide exclusion in the System for Award Management.

Florida Sheriffs Association
Cooperative Purchasing Program
Contract Terms and Conditions

FSA CPP reserves the right to accept or reject any and all bids, and to waive any minor irregularity, technicality or omission if it determines that doing so will serve the purchaser's best interest. FSA CPP reserves the right to make multiple awards for each item, if determined to be in the best interest of the FSA and the purchasers.

Awards will be posted on the FSA CPP website according to the date posted in the Bid Calendar.

2.21 BID TABULATIONS

The bid tabulation report will be posted on the FSA CPP website after the bid submission closes.

If there is a delay in posting the bid tabulation results, FSA CPP will post a notice of the delay and a revised date for posting of results.

2.22 MINOR IRREGULARITIES/RIGHT TO REJECT

The FSA CPP has the right to accept or reject any and all bids, or separate portions thereof, and to waive any minor irregularity, technicality or omission if the FSA CPP determines that doing so will serve its best interest or the best interest of the purchasers. A minor irregularity is a variation from the Terms and Conditions of this procurement that does not affect the price of the bid or give the Bidder a substantial advantage over other Bidders and thereby restrict or stifle competition and does not adversely impact the interests of the FSA or the purchasers. At its option, the FSA CPP may allow a Bidder to correct minor irregularities but is under no obligation to do so. In doing so, the FSA CPP may request a Bidder to provide clarifying information or additional materials to correct the irregularity. However, the FSA CPP will not request, and a Bidder may not provide, the FSA CPP with additional materials that affect the price of the bid or give the Bidder an advantage or benefit not enjoyed by other Bidders.

The FSA CPP may also reject any bids not submitted in the manner specified in this Invitation to Bid.

2.23 CONE OF SILENCE

This Invitation to Bid is subject to the Cone of Silence that begins the date the bid submission opens through the intent to award date as indicated in the Bid Calendar. During this period, all communications regarding this solicitation between FSA and Bidder will cease, except for procedural questions, questions regarding problems incurred in the use of the Bid System, or communications initiated by the FSA CPP. All permitted communications during this period shall be made in writing to the contact person identified in Section 1.01 of this Invitation to Bid.

Florida Sheriffs Association
Cooperative Purchasing Program
Contract Terms and Conditions

3.0 CONTRACT CONDITIONS

3.01 GENERAL REQUIREMENTS

Once the bid has been awarded, the Terms and Conditions of this document become the Contract between the FSA and the awarded Vendor. The Terms and Conditions apply to all items purchased from this Contract.

3.02 STATEMENT OF AUTHORITY

Each person signing the Contract warrants that they are duly authorized to do so and binds the respective party to the Contract.

3.03 VENDOR CONTACT INFORMATION

The Vendor shall maintain current contact information with FSA CPP at all times for sales and submission of Purchase Orders, quarterly reports and administrative fee payments. If a change occurs during the term of this Contract, the Vendor must notify FSA immediately.

3.04 ADDITIONS OR DELETIONS

FSA CPP reserves the right to add or delete any items from the Vendor's bid or this Contract when deemed to be in the best interest of FSA and purchasers, at its discretion. This decision to take action may be based upon and not limited to few or no sales, product recalls and other safety issues, Vendor or Manufacturer performance, or the product's lack of relevance.

For items that come to market during the Contract term, FSA CPP may authorize qualified and awarded Vendors to offer the new item under the existing Contract Terms and Conditions, if the Manufacturer authorizes a Vendor to sell the item. FSA CPP will request awarded Vendors submit pricing and will evaluate the responses prior to authorizing awarded Vendors to offer the new item.

3.05 CONTRACT EXTENSION

Contract Extension

The Contract may be extended by mutual agreement for up to two (2) additional years, on a year-to-year basis. FSA reserves the right to execute a Contract extension or to allow the Contract to fully or partially terminate and readvertise for bids, whichever is in the best interest of FSA.

The Vendor may request price adjustments for Contract extensions as provided for herein. If no request is received from the Vendor, the FSA will assume that the Vendor has agreed that the optional term may be exercised without a price adjustment. Any adjustment request received after the execution of an extension may not be considered unless otherwise provided for in this Contract.

Month-to-Month Continuation

In the event a new contract is not active at the time of this Contract's expiration, this Contract's Terms and Conditions shall extend on a month-to-month basis and shall not constitute an implied extension of the Contract. Such a month-to-month continuation shall be upon the compensation and payment provided herein.

Florida Sheriffs Association
Cooperative Purchasing Program
Contract Terms and Conditions

3.06 PRICE ADJUSTMENT

The Terms and Conditions provide the following methods of price adjustments:

- Annual Price Adjustments
- Changes to Manufacturer Production or Design
- Manufacturer Certified Adjustments
- Equitable Adjustments

Price adjustment requests must clearly substantiate a need to increase or decrease the price. Price adjustments will not be considered if Vendors are delinquent on administrative fee payments or have outstanding quarterly reports.

Annual Price Adjustment

The FSA CPP may consider annual price adjustments due to:

- Changes in the Producer Price Index (“PPI”) as published by the U.S. Department of Labor, Bureau of Labor Statistics (“BLS”); or
- As a result of changes to national or state standards that require substantial price adjustments.

FSA CPP may consider other documentation related to the change to national or state standards but is not obligated to grant price changes without literature from the Manufacturer. The FSA CPP will consider the request and will make a final determination on the change in price.

Changes to Manufacturer Production or Design

Significant changes by the Manufacturer to the production of and specification design may initiate a price adjustment request. FSA CPP will consider order dates, production factors, model year, or other conditions, as well as the replacement or complete redesign of items. Vendors must provide documentation from the Manufacturer.

Manufacturer Certified Adjustments

Vendors must provide documentation from the Manufacturer to FSA CPP that shows the additional costs or price adjustments imposed by the Manufacturer and substantiate the need for a related price adjustment for this Contract.

Equitable Adjustments

The FSA CPP, on behalf of FSA, may make an equitable adjustment to the Contract terms or pricing at its discretion.

3.07 CONDITIONS

It is understood and agreed that any item offered or shipped as a result of this Contract shall be the most current model offered.

3.08 PRODUCTION CUTOFF

Vendors shall notify the FSA CPP in writing no less than sixty (60) calendar days prior to the close of final order date by the Manufacturer when the final order date is during the term of the Contract. Purchase Orders received by the Vendor ten (10) business days prior to the final order date must be accepted and entered into the order system with

Florida Sheriffs Association
Cooperative Purchasing Program
Contract Terms and Conditions

the Manufacturer. Purchase Orders issued and received after the production cutoff date will be subject to availability. In this case, the Vendor and Manufacturer have the discretion whether to choose to provide next year's model at current year's prices until the end of the Contract term. If the Manufacturer cutoff date is during the term of the Contract and will affect the purchaser's ability to obtain the items, FSA CPP may consider substitutions from the same Manufacturer.

3.09 FACILITIES

The FSA CPP reserves the right to inspect the Vendor's facilities at any time with prior notice.

3.10 CAB AND CHASSIS PURCHASES

Vendors performing upfitting of cab and chassis should be licensed and certified to perform such work. Vendors are responsible for tag and title work if the chassis is completed by the Vendor or the Vendor's contracted third-party supplier. The requirements of Section 319.21, *Florida Statutes*, related to the Manufacturer statement of origin apply to cab and chassis purchases apply.

Cabs and chassis may be purchased from the Vendor without any required additional upfitting by the Vendor. Vendors are not responsible for tag and title if an incomplete chassis is requested and sold to the purchaser.

3.11 FACTORY-INSTALLED OPTIONS

All options specified as factory-installed are to be installed on the item at the primary site of assembly and are to be the Manufacturer's standard assembly-line product. Aftermarket and vendor-installed equipment will not be accepted as factory-installed. Vendors found supplying aftermarket or vendor-installed equipment where factory-installed are specified shall be required to retrieve all delivered items and supply new items meeting the specifications.

All factory-ordered options are to be original equipment Manufacturer ("OEM") and installed at the primary site of assembly unless otherwise noted by the Vendor and acknowledged in writing by the purchaser. Verbal agreements will not be recognized.

3.12 VENDOR-INSTALLED OPTIONS

All vendor-installed accessories, equipment, or options shall be installed according to the Manufacturer's specifications. All vendor-installed options must be manufactured by an established Manufacturer of the product provided. Vendors are required to disclose make and model of product being offered, the design and model must be approved by the purchaser prior to installation. Prior to any purchase, the Vendor must also disclose the warranty of any accessory, equipment or option that is less than or exceeds the factory or equipment warranty coverage. Any Vendor that violates this provision will be considered in default of the Contract. FSA may terminate the Contract in accordance with these Terms and Conditions.

3.13 NON-SCHEDULED OPTIONS

A non-scheduled option is an option not listed on the FSA CPP published award. Vendors may provide non-scheduled options at less than MSRP or the Published List Price. Non-scheduled options should be identified and listed as a separate line item with the price and discount on the Purchase Order. Non-scheduled options are covered under these Terms and Conditions.

Florida Sheriffs Association
Cooperative Purchasing Program
Contract Terms and Conditions

3.14 FORCE MAJEURE

A Vendor shall not be penalized for a delay resulting from the Vendor's failure to comply with delivery requirements if neither the fault nor the negligence of the Vendor or its employees contributed to the delay and the delay is due directly to acts of God, wars, acts of public enemies, strikes, fires, floods, or other similar cause wholly beyond the Vendor's control, or for any of the foregoing that third party suppliers if no alternate source of supply is available to the Vendor.

3.15 PARTS

Vendors may sell repair and replacement parts. Parts pricing must include the administrative fee. If a Vendor wishes to offer parts under this Contract, the Vendor must provide a price list to FSA and offer a discount below MSRP or Published List Price. Bidders and/or Vendors, as applicable, may include parts pricing sheet with the bid submission or following award. Bidders and/or Vendors, as applicable, may use the template offered in the bid system. Items listed below are required for the pricing sheet:

- Description.
- MSRP or List Price discount percentage.
- Exceptions to discount provided.
- Quantity discounts.

3.16 PURCHASE ORDERS

To initiate a purchase, a Purchase Order must be issued to the Vendor, which includes:

- FSA CPP contract title and number;
- FSA CPP item number;
- Make and model or item description; and
- Purchaser name, phone number and email address.

The Vendor's acceptance of a purchaser's order will indicate that the Vendor agrees to deliver an awarded item that will be fully compatible with all of its options. Production schedules and delivery dates should be discussed at the time the quote is provided to the purchaser, or if no quote is provided, when the Purchase Order is delivered to the Vendor. Vendor shall place the order with the Manufacturer within ten (10) business days of receipt of the Purchase Order. The Vendor shall ensure that all orders are placed in full compliance with the specifications and the Terms and Conditions of the Contract and the Purchase Order. Any changes that are required to bring an item into compliance with the various options due to an incorrect order will be accomplished at the Vendor's expense.

The Vendor should supply a confirmation of order to the purchaser and FSA CPP fifteen (15) calendar days from receipt of Purchase Order without request by the purchaser. Any additional information needed to complete this form should be obtained by the Vendor from the purchaser.

While it is recommended that a purchaser purchase from the zone which is closest to their location, it is not mandatory to do so. If the purchaser determines that a Vendor in another zone can better serve their needs, the purchaser may order from a Vendor in another zone. Vendors that provide awarded items outside of an awarded zone may upon mutual agreement between the Vendor and the purchaser charge a delivery fee.

If a Vendor receives a Purchase Order for an item for which they were not awarded, the Vendor must notify the purchaser and return the Purchase Order to the purchaser within three (3) business days.

Florida Sheriffs Association

Cooperative Purchasing Program

Contract Terms and Conditions

The Vendor must submit electronic copies of Purchase Orders within fifteen (15) calendar days of the Purchase Order issue date. Purchase Orders should be submitted through the reporting tool provided by FSA CPP. Purchase Orders received by the Vendor after this deadline must be submitted to FSA CPP as soon as possible with the date received by the Vendor and cause for the delay. Purchase Orders should contain the following required information:

- Purchaser name,
- Purchase Order number,
- Purchase Order issue date,
- FSA CPP contract title and number,
- Item number,
- Item make and model, or item description,
- Item price,
- Options by item, and
- Estimated delivery date.

Purchase Orders vary in format and information provided. If a Purchase Order does not include the required information, the Vendor must submit supplemental documentation to FSA CPP at the same time the Purchase Order is due. Such information may be in bid quotes, equipment proposals, confirmation of orders, or other documents. If a purchaser does not use Purchase Orders, written communication from the purchaser to the Vendor will be provided to FSA CPP.

3.17 REGISTRATION, TAG, AND TITLE

Title items shall be the responsibility of the Vendor. If the purchaser is a government agency, the purchaser has the right to choose to register and title the item. Costs of registration, tag and title shall not exceed the statutory rates.

3.18 DELIVERY

Vendors are to inspect the item to confirm the item meets or exceeds the FSA Base Specifications, Manufacturer specification, and Purchase Order. Deliveries not complying with these requirements may be rejected and will have to be redelivered at Vendor's expense.

Delivery shall be within the normal working hours of the purchaser, Monday through Friday, excluding holidays. Delivery schedules shall be agreed to by the purchaser and the Vendor. Vendor shall notify the purchaser no less than twenty-four (24) hours prior to delivery of the time and location, which shall reflect the mutually agreed upon delivery details. The Vendor shall be responsible for delivering items that are properly serviced, clean and in first class operating condition. Items shall be delivered with each of the following documents completed or included:

1. Copy of the Purchase Order.
2. Copy of the FSA Base Specifications.
3. Copy of Manufacturer's invoice, price sheet, build sheet or other documentation that verifies what components are included on the item(s) being delivered
4. Copy of the pre-delivery service report
5. Registration warranty certification
6. Owner's manual
7. Registration, tag and title or an application for the registration, as applicable

Florida Sheriffs Association
Cooperative Purchasing Program
Contract Terms and Conditions

All items with fuel tanks of thirty-five (35) gallons or less must contain no less than one quarter (1/4) tank of fuel as indicated by the fuel gauge at the time of delivery. For items that have more than thirty-five (35) gallons, a minimum of one eighth (1/8) of a tank of fuel must be provided. All electric vehicles must be delivered with a minimum charge level of 10 percent. The purchaser has the option to reject a vehicle with more than 350 odometer miles or may deduct \$0.51 cents per mile in excess of 350 miles from the invoice, unless distance above 350 miles was previously approved by the purchaser. Deliveries of less than 350 miles may be accomplished by driving the vehicle. Any delivery accomplished by driving the vehicle must be supervised and the driver must comply with Manufacturer's break-in requirements and all applicable traffic laws. Deliveries in excess of 350 miles shall be made by transport, or otherwise approved by the purchaser, however, this requirement shall not apply to incomplete chassis.

When items require service or adjustments upon delivery, the Vendor shall either remedy the defect or be responsible for reimbursing the Manufacturer's local authorized representative or other service provider to remedy the defect. Such service or adjustments shall be initiated by the Vendor within 48 hours after notification by a purchaser, not to include weekends and holidays. Delivery will not be considered complete until all services or adjustments are satisfactory, and the item is redelivered or repaired. The cost of any transportation required to address the defect shall be the responsibility of the Vendor until the items are satisfactory and accepted by the purchaser.

3.19 INSPECTION AND ACCEPTANCE

Final acceptance shall be given only after the purchaser inspects or confirms the item meets Contract specifications. Delivery of an item to a purchaser does not constitute acceptance for the purpose of payment. Inspection and acceptance will be at the purchaser's destination unless otherwise previously agreed upon location was provided in the Purchase Order. Should the delivered items differ in any respect from the FSA Base Specifications, payment can be withheld until such time as the Vendor completes the necessary corrective action.

3.20 INVOICING AND PAYMENTS

Invoicing and payments shall be the responsibility of the Vendor and purchaser placing orders using this Contract. Vendors must invoice each purchaser independently. The Vendor shall be paid upon submission of invoices to the purchaser after satisfactory delivery and acceptance of the items. While the Local Government Prompt Payment Act applies to ensure timely payment of Vendor invoices, the FSA CPP encourages purchasers to make payment within thirty (30) days of acceptance of the item. The Local Government Prompt Payment Act is defined in Sections 218.70–218.79, *Florida Statutes*.

3.23 WARRANTY

All warranties shall begin at the time of delivery and final acceptance by the purchaser. The purchaser's warranty should not be active for incomplete items and items delivered to a third-party supplier before final delivery.

3.24 QUARTERLY REPORTS

Quarterly reports are the contractual responsibility of each Vendor. Quarterly reports must be completed and submitted electronically. The quarterly report template shall be submitted using the tool provided by FSA CPP. Quarterly reports which do not adhere to the required format or are not complete of all Purchase Orders received and/or deliveries made during the quarter will be returned to the Vendor for correction.

Florida Sheriffs Association
Cooperative Purchasing Program
Contract Terms and Conditions

Quarterly reports are due no later than the 15th day of the month following the end of the quarter. Quarterly reports shall follow the schedule below for the duration of the Contract. If a Contract extension is executed, the quarterly reports will maintain the same schedule for future reporting periods.

Contract Years: October 1, 2025 – September 30, 2027

Year 1 Quarter 1:	October 1 – December 31	Q1 Report Due:	January 15
Year 1 Quarter 2:	January 1 – March 31	Q2 Report Due:	April 15
Year 1 Quarter 3:	April 1 – June 30	Q3 Report Due:	July 15
Year 1 Quarter 4:	July 1 – September 30	Q4 Report Due:	October 15
Year 2 Quarter 1:	October 1 – December 31	Q1 Report Due:	January 15
Year 2 Quarter 2:	January 1 – March 31	Q2 Report Due:	April 15
Year 2 Quarter 3:	April 1 – June 30	Q3 Report Due:	July 15
Year 2 Quarter 4:	July 1 – September 30	Q4 Report Due:	October 15

Quarterly reports must be submitted even if there are no sales or no deliveries in a quarter. If a Vendor has no sales within a quarter, the Vendor shall indicate “No sales this quarter” or “No deliveries this quarter” to FSA CPP by e-mail to Reports@flsheriffs.org.

FSA CPP reserves the right to modify the procedure for submitting quarterly reports during the term of the Contract. Such a change shall not materially modify the substance of the information to be reported but may change the method by which future quarterly reports are to be submitted. In the event of such a change, FSA CPP will provide written notice to all Vendors of the method by which future quarterly reports are to be submitted.

3.25 ADMINISTRATIVE FEE

The FSA CPP charges three quarters of one percent (.0075) to procure, process and administer the Contract. Payment of the administrative fees to the FSA CPP are the contractual responsibility of each awarded Vendor.

After receipt of payment from Contract purchases, the Vendor shall remit all administrative fees to the FSA CPP no later than fifteen (15) calendar days after the end of each quarter. All fees payable to the FSA CPP during any given quarter will be accompanied and supported by a quarterly report.

The administrative fee will remain payable to FSA CPP and no relief from payment of the administrative fee, nor any additional charge to recoup the administrative fee, will be permitted if a Vendor fails to incorporate the administrative fee in its bid pricing. The administrative fee should never be listed as a separate line item on any Purchase Order or invoice.

The administrative fee is based on the total Purchase Order amount of new items. Trade-ins, extended warranties and other exchanges will not reduce or impact the fee calculation.

The ACH form for electronic payment or wiring of funds is included in Appendix C. It is the preference of FSA CPP that all payments be electronically paid and submitted. If ACH is not available, checks for the administrative fee can be sent to:

Florida Sheriffs Association
Cooperative Purchasing Program
2617 Mahan Drive
Tallahassee, FL 32308

Florida Sheriffs Association
Cooperative Purchasing Program
Contract Terms and Conditions

3.26 LIQUIDATED DAMAGES

The Vendor warrants that the item supplied to the purchaser shall conform in all respects to the standards set forth in the applicable FSA Base Specifications and the failure to comply with this condition will be considered as a breach of Contract. Any liquidated damages levied because of inadequacies or failures to comply with these requirements shall be borne solely by the Vendor responsible for same.

Failure to submit the administrative fee with accompanying quarterly reports to FSA CPP within fifteen (15) calendar days following the end of each quarter may result in the imposition of liquidated damages. Vendors failing to submit administrative fees and/or quarterly reports will incur liquidated damages in the amount of \$25.00 for each calendar day that fees and reports are past due, beginning on the 16th day following the end of the quarter.

If a civil action is initiated by the FSA to recover administrative fees or liquidated damages as set forth in this section, the prevailing party shall be entitled to its reasonable attorneys' fees and costs incurred in the litigation. The venue shall lie in the Circuit Court for the Second Judicial Circuit in and for Leon County, Florida.

When quarterly reports are late, liquidated damages are to be included in Vendor's quarterly report and administrative fee submission. Liquidated damages that remain unpaid beyond forty-five (45) calendar days can result in FSA CPP, at its sole discretion, implementing Contract compliance actions, including but not limited to, suspension, limited participation by specifications or zones, disqualification from future solicitations, or termination of this Contract for cause pursuant to the Terms and Conditions.

Schedule of Liquidated Damages

Failure to submit quarterly report on time	\$25.00 per calendar day
Failure to submit administrative fee on time	\$25.00 per calendar day
Failure to report a Purchase Order to FSA CPP within 15 calendar days of the Purchase Order issue date	\$100.00 per Purchase Order
Failure to Report Sales	.0075 of the sales price plus 1.5% each month following the delivery date.

Vendor agrees and acknowledges that its failure to take any of the actions specified in the above schedule will result in liquidated damages to this Contract. Vendor agrees and acknowledges that these liquidated damages are not intended to be and do not constitute a penalty and that these amounts are reasonably calculated to compensate the FSA CPP for the damages that it will incur as a result of the Vendor's failure to take the specified actions.

**Florida Sheriffs Association
Cooperative Purchasing Program
Contract Terms and Conditions**

Appendix A: Zone Map

FSA CONTRACT ZONE MAP



v.10_2015

Florida Sheriffs Association
Cooperative Purchasing Program
 Contract Terms and Conditions

Appendix B. Bid Calendar

FSA25-VEH23.0 Bid Calendar	Date
Bid Announcement	3/28/25
Voluntary Interested Bidder Workshop FSA25-VEH23.0	6/4/25
New Items & Specifications Submissions Due	6/12/25
Mandatory Pre-Bid Meeting FSA25-VEH23.0 and VendorLink Training	7/15/25
Requests for Clarifications Due to FSA	7/24/25
FSA Response to Requests for Clarifications	7/30/25
Bid System Opens	8/1/25
Cone of Silence	8/1/25-9/23/25
Bid Submissions Due	9/2/25
Bid Tabulations Posted	9/3/25
Public Bid Opening	9/3/25
Bid Evaluations	9/15/25-9/19/25
Intent To Award	9/23/25
Final Award	10/1/25

Florida Sheriffs Association
Cooperative Purchasing Program
Contract Terms and Conditions

Appendix C: ACH Payments



PROTECTING, LEADING & UNITING SINCE 1893
FLORIDA SHERIFFS ASSOCIATION

2617 Mahan Drive
Tallahassee, Florida 32308

p: (850) 877-2165 f: (850) 878-8665
fisheriffs.org    

TO: All Customers of the Florida Sheriffs Association

SUBJECT: Automated Payments through ACH

The Florida Sheriffs Association values the integrity of our business operations and knows that our partners do as well. As we continue to strengthen this partnership, FSA invites each company to offer payments to FSA via ACH. It is our goal to secure payments and reduce fraudulent transactions and this will be our primary method of accepting payments due to recent efforts to defraud FSA. Florida Sheriffs Association can be added to your company's list of vendors authorized to be paid via electronic payment for no additional fee.

Florida Sheriffs Association's Banking Information is as follows:

Checking Account
Capital City Bank
Routing Number: 063100688
Account Number: 0010867001

Please email any payment remittance information to accounting@flsheriffs.org.

If you choose to make ACH payments to the association, there is no additional charge. The information above can be used to pay with a wire transfer as well, but if you choose to pay via wire, there is a charge of \$25 per wire that you will need to add to your payment.

If you have any questions at all, please contact Trish Eldridge at teldridge@flsheriffs.org or call (850) 559-5668.

Sincerely,

Trish Eldridge

Director of Accounting and Finance
Florida Sheriffs Association

Florida Sheriffs Association
Cooperative Purchasing Program
Contract Terms and Conditions

Appendix D: Federal Clauses

Applicability of Third-Party Contract Provisions*

(Excluding micro-purchases, as defined in 48 C.F.R. Subpart 2.1, except Davis-Bacon requirements apply to construction contracts exceeding \$2,000.) In addition to other provisions negotiated with purchasers placing federally funded Purchase Orders, Vendors must comply with the following provisions upon award of a federally funded Purchase Order:

PROVISION	Professional Services/A&E	Operations/ Management	Construction	Materials & Supplies
Equal Employment Opportunity			All	
Davis-Bacon Act			>\$2,000	
Copeland "Anti-Kickback" Act			>\$2,000	
Contract Work Hours and Safety Standards Act	>\$100,000	>\$100,000	>\$100,000	>\$100,000
Rights to Inventions Made Under a Contract or Agreement	If the Purchase Order involves performance of experimental, developmental or research work	If the Purchase Order involves performance of experimental, developmental or research work	If the Purchase Order involves performance of experimental, developmental or research work	If the Purchase Order involves performance of experimental, developmental or research work
Clean Air Act	>\$150,000	>\$150,000	>\$150,000	>\$150,000
Federal Water Pollution Control Act	>\$150,000	>\$150,000	>\$150,000	>\$150,000
Debarment and Suspension	All	All	All	All
Byrd Anti-Lobbying Amendment	>\$100,000	>\$100,000	>\$100,000	>\$100,000
Procurement of Recovered Materials	All	All	All	All
Prohibition on Certain Telecommunications and Video Surveillance Services or Equipment	All	All	All	All
Domestic Preferences for Procurements	All	All	All	All

*References to the Code of Federal Regulations ("C.F.R.") or United States Code ("U.S.C.") were accurate at the time of publication. It is the responsibility of the Bidder to ensure compliance is met of the referenced state and federal laws within the published rules.

EQUAL EMPLOYMENT OPPORTUNITY: Except as otherwise provided under 41 C.F.R. Part 60, all contracts that meet the definition of "federally assisted construction contract" in 41 C.F.R. Part 60-1.3 must include the equal opportunity clause provided under 41 C.F.R. 60-1.4(b), in accordance with Executive Order 11246, "Equal Employment Opportunity" (30 FR 12319, 12935, 3 C.F.R. Part, 1964-1965 Comp., p. 339), as amended by Executive Order 11375, "Amending Executive Order 11246 Relating to Equal Employment Opportunity," and implementing regulations at 41 C.F.R. part 60, "Office of Federal Contract Compliance Programs, Equal Employment Opportunity, Department of

Florida Sheriffs Association
Cooperative Purchasing Program
Contract Terms and Conditions

Labor.” The clause set forth in 41 C.F.R. 60-1.4(b) is incorporated herein by reference. Vendor must comply with this clause and include this clause in all lower-tier federal assisted construction contracts.

DAVIS-BACON ACT, as amended (40 U.S.C. 3141-3148): When required by Federal program legislation, all prime construction contracts in excess of \$2,000 awarded by non-Federal entities must include a provision for compliance with the Davis-Bacon Act (40 U.S.C. 3141-3144, and 3146-3148) as supplemented by Department of Labor regulations (29 C.F.R. Part 5, “Labor Standards Provisions Applicable to Contracts Covering Federally Financed and Assisted Construction”). In accordance with the statute, contractors must be required to pay wages to laborers and mechanics at a rate not less than the prevailing wages specified in a wage determination made by the Secretary of Labor. In addition, contractors must be required to pay wages not less than once a week. The non-Federal entity must place a copy of the current prevailing wage determination issued by the Department of Labor in each solicitation. The decision to award a contract or subcontract must be conditioned upon the acceptance of the wage determination. The non-Federal entity must report all suspected or reported violations to the Federal awarding agency. The contracts must also include a provision for compliance with the Copeland “Anti-Kickback” Act (40 U.S.C. 3145), as supplemented by Department of Labor regulations (29 C.F.R. Part 3, “Contractors and Subcontractors on Public Building or Public Work Financed in Whole or in Part by Loans or Grants from the United States”). The Act provides that each contractor or subrecipient must be prohibited from inducing, by any means, any person employed in the construction, completion, or repair of public work, to give up any part of the compensation to which he or she is otherwise entitled. The non-Federal entity must report all suspected or reported violations to the Federal awarding agency. Vendors performing construction must comply with all applicable provisions of the Davis-Bacon Act and include this clause in all lower-tier subcontracts for construction.

CONTRACT WORK HOURS AND SAFETY STANDARDS ACT (40 U.S.C., chapter 37): Vendor shall comply with Sections 102 and 107 of the Contract Work Hours and Safety Standards Act (40 U.S.C., chapter 37), as supplemented by Department of Labor regulations (29 C.F.R. part 5).

(a) Overtime requirements. Neither Vendor nor any contractor or subcontractor contracting for any part of the purchase order work which may require or involve the employment of laborers or mechanics shall require or permit any such laborer or mechanic in any workweek in which he or she is employed on such work to work in excess of forty hours in such workweek unless such laborer or mechanic receives compensation at a rate not less than one and one-half times the basic rate of pay for all hours worked in excess of forty hours in such workweek.

(b) Violation; liability for unpaid wages; liquidated damages. In the event of any violation of the clause set forth in Paragraph 15(a), Vendor and any subcontractor responsible therefor shall be liable for the unpaid wages. In addition, Vendor or such subcontractor shall be liable to the United States (in the case of work done under the Contract for the District of Columbia or a territory, to such District or to such territory), for liquidated damages. Such liquidated damages shall be computed with respect to each individual laborer or mechanic, including watchmen and guards, employed in violation of the clause set forth in Paragraph 15(a), in the sum of \$29 for each calendar day on which such individual was required or permitted to work in excess of the standard workweek of forty hours without payment of the overtime wages required by the clause set forth in Paragraph 15(a) of this section.

(c) Withholding for unpaid wages and liquidated damages. Purchaser shall upon its own action or upon written request of an authorized representative of the Department of Labor withhold or cause to be withheld, from any moneys payable on account of work performed by Vendor or a subcontractor under the purchase order or any other Federal contract with Purchaser, or any other federally-assisted contract subject to the Contract Work Hours and Safety Standards Act, which is held by Purchaser, such sums as may be determined to be necessary to satisfy any liabilities of Vendor or its subcontractor for unpaid wages and liquidated damages as provided in the clause set forth in Paragraph (a).

(d) Subcontracts. Vendor shall insert in any subcontracts over \$100,000 for construction and other purposes that involve the employment of mechanics or laborers, the clauses set forth in Paragraphs (a) through (d) and also a clause requiring the subcontractors to include these clauses in any lower-tier subcontracts.

Florida Sheriffs Association
Cooperative Purchasing Program
Contract Terms and Conditions

RIGHTS TO INVENTIONS MADE UNDER A CONTRACT OR AGREEMENT: If the Federal award meets the definition of “funding agreement” under 37 C.F.R. § 401.2 (a) and the recipient or subrecipient wishes to enter into a contract with a small business firm or nonprofit organization regarding the substitution of parties, assignment or performance of experimental, developmental, or research work under that “funding agreement,” the recipient or subrecipient must comply with the requirements of 37 C.F.R. Part 401, “Rights to Inventions Made by Nonprofit Organizations and Small Business Firms Under Government Grants, Contracts and Cooperative Agreements,” and any implementing regulations issued by the awarding agency. Vendor shall comply with these requirements when performing a purchase order involving experimental, developmental or research work and flowdown this clause to lower-tier subcontractors performing such work.

CLEAN AIR ACT (42 U.S.C. 7401 *et seq.*) and the FEDERAL WATER POLLUTION CONTROL ACT (33 U.S.C. 1251 *et seq.*), as amended: Vendor agrees to comply with all applicable standards, orders or regulations issued pursuant to the Clean Air Act (42 U.S.C. 7401 *et seq.*) and the Federal Water Pollution Control Act as amended (33 U.S.C. 1251 *et seq.*). Violations shall be reported to the Federal awarding agency and the Regional Office of the Environmental Protection Agency (EPA). Vendor shall comply with the requirements of Clean Air Act and the Federal Water Pollution Control Act and include this clause in all lower-tier subcontracts with a value over \$150,000.

DEBARMENT AND SUSPENSION (E.O.s 12549 and 12689): By accepting or performing this purchase order, Vendor certifies that it is not identified in the Exclusions area of the System for Award Management as being currently debarred, suspended, proposed for debarment, or otherwise excluded (“SAM Exclusion”). Vendor shall obtain similar certifications from its lower-tier subcontractors for each subcontract in excess of \$25,000 and Vendor shall not award lower-tier subcontracts in excess of \$25,000 to an entity subject to a SAM Exclusion.

LOBBYING RESTRICTIONS (31 U.S.C. 1352): By accepting or performing this purchase order, Vendor certifies that it will not and has not used Federal appropriated funds to pay any person or organization for influencing or attempting to influence an officer or employee of any agency, a member of Congress, officer or employee of Congress, or an employee of a member of Congress in connection with obtaining any Federal contract, grant or any other award covered by 31 U.S.C. 1352. Vendor shall also disclose to Purchaser any lobbying with non-Federal funds that takes place in connection with obtaining any Federal award or contract. Vendor shall flow down this clause and require this certification for lower-tier subcontractors with a subcontract of \$100,000 or more. Vendor shall provide its disclosure and all disclosures received from lower-tier subcontractors to Purchaser.

PROCUREMENT OF RECOVERED MATERIALS: A non-Federal entity that is a state agency or agency of a political subdivision of a state and its contractors must comply with section 6002 of the Solid Waste Disposal Act, as amended by the Resource Conservation and Recovery Act. The requirements of Section 6002 include procuring only items designated in guidelines of the Environmental Protection Agency (“EPA”) at 40 C.F.R. part 247 that contain the highest percentage of recovered materials practicable, consistent with maintaining a satisfactory level of competition, where the purchase price of the item exceeds \$10,000 or the value of the quantity acquired during the preceding fiscal year exceeded \$10,000; procuring solid waste management services in a manner that maximizes energy and resource recovery; and establishing an affirmative procurement program for procurement of recovered materials identified in the EPA guidelines. Vendor shall comply with this clause and include this clause in all lower-tier subcontracts.

PROHIBITION ON CERTAIN TELECOMMUNICATIONS AND VIDEO SURVEILLANCE SERVICES OR EQUIPMENT:

(a) Recipients and subrecipients are prohibited from obligating or expending loan or grant funds to:

- (1) Procure or obtain;
- (2) Extend or renew a contract to procure or obtain; or
- (3) Enter into a contract (or extend or renew a contract) to procure or obtain equipment, services, or systems that uses covered telecommunications equipment or services as a substantial or essential

Florida Sheriffs Association
Cooperative Purchasing Program
Contract Terms and Conditions

component of any system, or as critical technology as part of any system. As described in Public Law 115-232, section 889, covered telecommunications equipment is telecommunications equipment produced by Huawei Technologies Company or ZTE Corporation (or any subsidiary or affiliate of such entities).

(i) For the purpose of public safety, security of government facilities, physical security surveillance of critical infrastructure, and other national security purposes, video surveillance and telecommunications equipment produced by Hytera Communications Corporation, Hangzhou Hikvision Digital Technology Company, or Dahua Technology Company (or any subsidiary or affiliate of such entities).

(ii) Telecommunications or video surveillance services provided by such entities or using such equipment.

(iii) Telecommunications or video surveillance equipment or services produced or provided by an entity that the Secretary of Defense, in consultation with the Director of the National Intelligence or the Director of the Federal Bureau of Investigation, reasonably believes to be an entity owned or controlled by, or otherwise connected to, the government of a covered foreign country.

(b) In implementing the prohibition under Public Law 115-232, section 889, subsection (f), paragraph (1), heads of executive agencies administering loan, grant, or subsidy programs shall prioritize available funding and technical support to assist affected businesses, institutions and organizations as is reasonably necessary for those affected entities to transition from covered communications equipment and services, to procure replacement equipment and services, and to ensure that communications service to users and customers is sustained.

(c) See Public Law 115-232, section 889 for additional information.

DOMESTIC PREFERENCES FOR PROCUREMENTS:

(a) As appropriate and to the extent consistent with law, the non-Federal entity should, to the greatest extent practicable under a Federal award, provide a preference for the purchase, acquisition, or use of goods, products, or materials produced in the United States (including but not limited to iron, aluminum, steel, cement, and other manufactured products). Vendor agrees to comply with the requirements of this clause and include the requirements of this clause in all subawards including all contracts and purchase orders for work or products under this award.

(b) For purposes of this section:

(1) "Produced in the United States" means, for iron and steel products, that all manufacturing processes, from the initial melting stage through the application of coatings, occurred in the United States.

(2) "Manufactured products" means items and construction materials composed in whole or in part of non-ferrous metals such as aluminum; plastics and polymer-based products such as polyvinyl chloride pipe; aggregates such as concrete; glass, including optical fiber; and lumber.

FSA Cooperative Purchasing Program



FSA25-VEH23.0: Heavy Trucks and Buses Base Specifications



**FSA25-VEH23.0: Heavy Trucks and Buses
Item Group Specifications**

Item Groups Summary	2
Buses Electric: 19 to 20 Passenger Capacity Range, Van-Type Cutaway Chassis	4
Buses Electric: 20 to 52 Passenger Capacity Range, Conventional-Type Chassis	5
Buses Electric: 44 To 80 Passenger Capacity Range, Commercial-Type Chassis.....	6
Buses: 14 to 25 Passenger Capacity Range, Van-Type Cutaway Chassis	7
Buses: 20 to 52 Passenger Capacity Range, Conventional Truck-Type Cutaway Chassis	8
Buses: 33 to 54 Passenger Capacity Range, Commercial-Type, Rear Engine Chassis.....	9
Buses: 36 to 52 Passenger Capacity Range, Commercial-Type, Front Engine Chassis	10
Cab and Chassis Trucks Electric: 54,000 lbs. GVWR 4x6 Semi Tractor.....	11
Cab and Chassis Trucks Electric: Tilt Cab 26,000 lbs. GVWR (DRW) 4x2	12
Cab and Chassis Trucks Electric: Conventional Cab 33,000 lbs. GVWR (DRW) 4x2	13
Cab and Chassis Trucks: 17,500 lbs. GVWR (DRW) 4x2	14
Cab and Chassis Trucks: 17,500 lbs. GVWR (DRW) 4x4	15
Cab and Chassis Trucks: 25,500 lbs. GVWR (DRW) 4x2	16
Cab and Chassis Trucks: 30,000 lbs. GVWR (DRW) 4x2	17
Cab and Chassis Trucks: 52,000 lbs. GVWR Semi Tractor 4x6	18
Cab and Chassis Trucks: 52,000 lbs. GVWR Truck 4x6.....	19
Cab and Chassis Trucks: 12,000 lbs. GVWR (DRW) 4x2 Tilt Cab	20
Cab and Chassis Trucks: 25,000 lbs. GVWR (DRW) 4x2 Tilt Cab	21
Refuse Truck Electric: 60,000 lbs. GVWR 4x6 (cab and chassis only)	22
Refuse Truck: 60,000 lbs. GVWR 4x6 (cab and chassis only)	23
Refuse Truck: Compact 9.5 Cubic Yds. Self-Loading Refuse Truck	24
Tactical Armored Vehicle	25
Terminal Tractor	26
Spray Truck: 19,500 lbs. GVWR 4x2, Mounted 1,000 gal ROW Spray Unit	27
Utility Truck: 33,000 lbs. GVWR 4x4, Digger Derrick	29
Utility Truck: 33,000 lbs. GVWR 4x4, Mounted Aerial Device	32



FSA25-VEH23.0: Heavy Trucks and Buses Item Group Specifications

Item Groups Summary

All bid items shall be built to manufacturer base specifications for the item or model number indicated and shall include all standard manufacturer equipment unless otherwise specified. If not already included in manufacturer base specifications, all vehicles shall include air conditioning. When requested by the purchaser, vendors must submit detailed specifications for the item and options offered. Vendors are responsible for providing a chassis (including front axle, rear axle, wheels, and tires) of sufficient GVWR to safely accommodate all options selected by the purchaser. In all areas of these specifications, bidders must comply with current Federal Motor Vehicle Safety Standards (FMVSS, where applicable), and National Highway Traffic Safety Administration (NHTSA) standards.

Buses

- Buses Electric: 19 to 20 Passenger Capacity Range, Van-Type Cutaway Chassis
- Buses Electric: 20 to 52 Passenger Capacity Range, Conventional-Type Chassis
- Buses Electric: 44 To 80 Passenger Capacity Range, Commercial-Type Chassis
- Buses: 14 to 25 Passenger Capacity Range, Van-Type Cutaway Chassis
- Buses: 20 to 52 Passenger Capacity Range, Conventional Truck-Type Cutaway Chassis
- Buses: 33 to 54 Passenger Capacity Range, Commercial-Type, Rear Engine Chassis
- Buses: 36 to 52 Passenger Capacity Range, Commercial-Type, Front Engine Chassis

Cab and Chassis Trucks

- Cab and Chassis Trucks Electric: 54,000 lbs. GVWR 4x6 Semi Tractor
- Cab and Chassis Trucks Electric: Tilt Cab 26,000 lbs. GVWR (DRW) 4x2
- Cab and Chassis Trucks Electric: Conventional Cab 33,000 lbs. GVWR (DRW) 4x2
- Cab and Chassis Trucks: 17,500 lbs. GVWR (DRW) 4x2
- Cab and Chassis Trucks: 17,500 lbs. GVWR (DRW) 4x4
- Cab and Chassis Trucks: 25,500 lbs. GVWR (DRW) 4x2
- Cab and Chassis Trucks: 30,000 lbs. GVWR (DRW) 4x2
- Cab and Chassis Trucks: 52,000 lbs. GVWR Semi Tractor 4x6
- Cab and Chassis Trucks: 52,000 lbs. GVWR Truck 4x6
- Cab and Chassis Trucks: 12,000 lbs. GVWR (DRW) 4x2 Tilt Cab*
- Cab and Chassis Trucks: 25,000 lbs. GVWR (DRW) 4x2 Tilt Cab*
- Refuse Truck Electric: 60,000 lbs. GVWR 4x6 (cab and chassis only)
- Refuse Truck: 60,000 lbs. GVWR 4x6 (cab and chassis only)
- Refuse Truck: Compact 9.5 Cubic Yds. Self-Loading Refuse Truck
- Tactical Armored Vehicles
- Terminal Tractor

Turn-Key Trucks

- Spray Truck: 19,500 lbs. GVWR 4x2, Mounted 1,000 gal ROW Spray Unit**
 - Utility Truck: 33,000 lbs. GVWR 4x4, Digger Derrick**
 - Utility Truck: 33,000 lbs. GVWR 4x4, Mounted Aerial Device**
-



FSA25-VEH23.0: Heavy Trucks and Buses Item Group Specifications

- Outriggers: A frame outriggers, swivel type stabilizer pads, 6 in club feet, poly outrigger pads, pad holder
 - Ground Cable: 2/0 ground cable per ASTM F855-04, 50', ground clamp, 3-point ground system, 3 ground lugs, 2 ferrules, cable bracket; purchaser must verify this ground system meets their entity's requirements
 - Upper Controls: Single stick type w/ enable, engine stop/start, platform leveling, platform tilt, on demand throttle disable
 - Lower Controls: Platform tilt, individual boom controls located at turntable, winch control, throttle disable, upper/lower platform disable, engine start/stop
 - Outrigger Controls: Located at rear, each side for view of outrigger placement, outrigger interlock, controls for auxiliary tool outlets, motion alarm, remote engine stop/start
 - Auxiliary Letdown: For emergency descent of boom, electric 12 volt, pedestal control
 - Color: White, matching truck and mounted body
-



**FSA25-VEH23.0: Heavy Trucks and Buses
Item Group Specifications**

Buses: 14 to 25 Passenger Capacity Range, Van-Type Cutaway Chassis

FSA Item Group Description

- Engine: Gas
- Transmission: Automatic
- GVWR: 10,350 lbs. (approximate, sized to meet passenger capacity)
- Passenger Seating: Seating for 14 passengers minimum



**FSA25-VEH23.0: Heavy Trucks and Buses
Item Group Specifications**

Buses: 20 to 52 Passenger Capacity Range, Conventional Truck-Type Cutaway Chassis

FSA Item Group Description

- Engine: 240 hp minimum, 6-cylinder diesel
- Transmission: Allison (or equivalent) 6-speed automatic
- GVWR: 23,500 lbs. (approximate, sized to meet passenger capacity)
- Passenger Seating: Seating for 20 passengers minimum



**FSA25-VEH23.0: Heavy Trucks and Buses
Item Group Specifications**

Buses: 33 to 54 Passenger Capacity Range, Commercial-Type, Rear Engine Chassis

FSA Item Group Description

- Engine: 240 hp minimum, 6-cylinder diesel
- Transmission: Allison (or equivalent) 5-speed automatic
- GVWR: 36,000 lbs. (approximate, sized to meet passenger capacity)
- Passenger Seating: Seating for 33 passengers minimum



**FSA25-VEH23.0: Heavy Trucks and Buses
Item Group Specifications**

Buses: 36 to 52 Passenger Capacity Range, Commercial-Type, Front Engine Chassis

FSA Item Group Description

- Engine: 240 hp minimum, 6-cylinder diesel
- Transmission: Allison (or equivalent) 5-speed automatic
- GVWR: 36,000 lbs. (approximate, sized to meet passenger capacity)
- Passenger Seating: Seating for 36 passengers minimum



**FSA25-VEH23.0: Heavy Trucks and Buses
Item Group Specifications**

Cab and Chassis Trucks Electric: 54,000 lbs. GVWR 4x6 Semi Tractor

FSA Item Group Description

- Electric Motor: 340 kW, 455 hp minimum
- Transmission: 2-speed transmission, differential mounted
- Batteries: 375 kW storage capacity, frame mounted
- GVWR: 54,000 lbs.



**FSA25-VEH23.0: Heavy Trucks and Buses
Item Group Specifications**

Cab and Chassis Trucks Electric: Tilt Cab 26,000 lbs. GVWR (DRW) 4x2

FSA Item Group Description

- Electric Motor: 250 kW, 355 hp minimum
- Transmission: Manufacturer's standard automatic transmission
- Batteries: 282 kW storage capacity
- GVWR: 26,000 lbs.



**FSA25-VEH23.0: Heavy Trucks and Buses
Item Group Specifications**

Cab and Chassis Trucks Electric: Conventional Cab 33,000 lbs. GVWR (DRW) 4x2

FSA Item Group Description

- Electric Motor: 260 hp (peak) 185 (continuous)
- Transmission: Direct drive (no transmission)
- Batteries: 210 kW battery pack
- GVWR: 33,000 lbs.



**FSA25-VEH23.0: Heavy Trucks and Buses
Item Group Specifications**

Cab and Chassis Trucks: 17,500 lbs. GVWR (DRW) 4x2

FSA Item Group Description

- Engine: Diesel engine, minimum 190 hp
- Transmission: Manufacturer's standard automatic transmission
- GVWR: 17,500 lbs.



**FSA25-VEH23.0: Heavy Trucks and Buses
Item Group Specifications**

Cab and Chassis Trucks: 17,500 lbs. GVWR (DRW) 4x4

FSA Item Group Description

- Engine: Diesel engine, minimum 190 hp
- Transmission: Manufacturer's standard automatic transmission
- GVWR: 17,500 lbs.



**FSA25-VEH23.0: Heavy Trucks and Buses
Item Group Specifications**

Cab and Chassis Trucks: 25,500 lbs. GVWR (DRW) 4x2

FSA Item Group Description

- Engine: Diesel engine, minimum 200 hp
- Transmission: Manufacturers standard automatic transmission or approved equivalent (with PTO provision)
- GVWR: 25,500 lbs.



**FSA25-VEH23.0: Heavy Trucks and Buses
Item Group Specifications**

Cab and Chassis Trucks: 30,000 lbs. GVWR (DRW) 4x2

FSA Item Group Description

- Engine: Diesel engine, minimum 200 hp
- Transmission: Manufacturers standard automatic transmission or approved equivalent (with PTO provision)
- GVWR: 30,000 lbs.



**FSA25-VEH23.0: Heavy Trucks and Buses
Item Group Specifications**

Cab and Chassis Trucks: 52,000 lbs. GVWR Semi Tractor 4x6

FSA Item Group Description

- Engine: 350 hp 6-cylinder diesel engine, manufacturer's 11L minimum
- Transmission: 10-speed manual with OD or approved equivalent
- GVWR: 52,000 lbs.



**FSA25-VEH23.0: Heavy Trucks and Buses
Item Group Specifications**

Cab and Chassis Trucks: 52,000 lbs. GVWR Truck 4x6

FSA Item Group Description

- Engine: 350 hp 6-cylinder diesel engine, manufacturer's 11L minimum
- Transmission: 10-speed manual with OD or approved equivalent
- GVWR: 52,000 lbs.



**FSA25-VEH23.0: Heavy Trucks and Buses
Item Group Specifications**

Cab and Chassis Trucks: 12,000 lbs. GVWR (DRW) 4x2 Tilt Cab

FSA Item Group Description

- Engine: 200 hp diesel engine
- Transmission: Manufacturer's standard automatic transmission
- GVWR: 12,000 lbs.
- Tilt cab only



**FSA25-VEH23.0: Heavy Trucks and Buses
Item Group Specifications**

Cab and Chassis Trucks: 25,000 lbs. GVWR (DRW) 4x2 Tilt Cab

FSA Item Group Description

- Engine: 250 hp diesel engine
- Transmission: Manufacturer's standard automatic transmission
- GVWR: 25,000 lbs.
- Tilt cab only



**FSA25-VEH23.0: Heavy Trucks and Buses
Item Group Specifications**

Refuse Truck Electric: 60,000 lbs. GVWR 4x6 (cab and chassis only)

FSA Item Group Description

- Motor: Electric powered with the OEM recommended electric motor(s) for this application with no less than a 350kW rating
- Batteries: Largest available battery for model bid, electric charging system on the truck must be SAE J1772 compliant
- GVWR: 60,000 lbs.



**FSA25-VEH23.0: Heavy Trucks and Buses
Item Group Specifications**

Refuse Truck: 60,000 lbs. GVWR 4x6 (cab and chassis only)

FSA Item Group Description

- Engine: 300 hp 6-cylinder diesel engine, manufacturer's 11L minimum
- Transmission: Allison 4500 RDS automatic transmission
- GVWR: 60,000 lbs.



**FSA25-VEH23.0: Heavy Trucks and Buses
Item Group Specifications**

Refuse Truck: Compact 9.5 Cubic Yds. Self-Loading Refuse Truck

FSA Item Group Description

- Engine: 70 hp diesel engine, EPA compliant
- Transmission: Hydrostatic transmission, four-wheel drive
- GVWR: 12,900 lbs.



**FSA25-VEH23.0: Heavy Trucks and Buses
Item Group Specifications**

Tactical Armored Vehicle

FSA Item Group Description

- Engine: 6.7LV-8 Turbo diesel, 330 hp
- Transmission: 10-speed automatic TorqShift with OD
- GVWR: GVWR sized to built vehicle (19,500 lbs. approximate)



**FSA25-VEH23.0: Heavy Trucks and Buses
Item Group Specifications**

Terminal Tractor

FSA Item Group Description

- Engine: 173 hp diesel engine
 - Transmission: 7-speed automatic (6 forward, 1 reverse)
-



FSA25-VEH23.0: Heavy Trucks and Buses Item Group Specifications

Spray Truck: 19,500 lbs. GVWR 4x2, Mounted 1,000 gal ROW Spray Unit

This unit will meet all local, state, and federal standards associated with this type of vehicle and will be completely plumbed and tested, and ready to work when delivered.

FSA Item Group Description:

- Complete ready-to-work unit.
- Standard manufacturer equipment and specifications, plus 2 keys and/or fobs (if not included).
- Make: Truck with mounted 1,000 gal ROW spray unit
- Engine: Diesel engine, Turbocharged
- GVWR: 19,500 lbs.
- Transmission: Automatic
- Suspension: 19,500 lbs. heavy duty suspension, w/ stabilizer bars front and rear
- Frame: Heavy duty frame
- Wheelbase: 193", CA 108"
- Steering: Power steering
- Brakes: ABS, manufacturers standard brake system
- Wheels: Painted steel wheels 19.5, hub piloted
- Tires: 225/70R x 19.5 tires, on road/off road traction type on rear axle
- Chassis Equipment: Tow hooks on front, 40 gal fuel tank, steel front bumper, mudflaps, backup alarm
- Cab Exterior: Tow type mirrors, w/ convex spot mirrors, tinted glass
- Cab Interior: Electric windows and electric door locks, A/C and heater, vinyl bench seat, rubber flooring, gauge package, AM/FM radio, intermittent windshield wipers, tilt/telescope steering
- Color: Factory bright white

Mounted Body

- Mounted Body: Aluminum, flatbed type, welded body w/ expanded metal headache rack, approximately 96" x 186", 36" aluminum locking tool box
 - Lighting: All LED DOT lighting, strobe lights
 - Tank: 1,025 gal polyethylene tank, approximately 49" diameter x 139" length x 16" manway, horizontal leg type, adjustable tank mix jet agitation, 2" overhead ground fill w/ camlock and valve
 - Mix Tank: 10 gal polyethylene mix tank, inductor tank for loading chemicals into main tank from the ground
 - Eyewash/Handwash Tank: 20 gal, 12 volt pump
 - Hose reel: 300' capacity of ½" agricultural hose, electric rewind, roller guides, JD-9 spray gun and hose included
 - Pump: Honda GX-390, electric start engine, Hypro 9263C-C-SP self-priming centrifugal pump, 12 volt clutch, 122 GPM max, 156 PSI max, 1 ¼" outlet, 1 ½" inlet
 - Spray Head: 5-section spray head, pivoting type from passenger side to drivers side, manual extension, power tilt, bottom spray nozzles, 5', 10', 20', and 30' spray swaths
 - In Cab Controls: In cab controls for 5-section spray boom, pump pressure, strobe lights, tilt
-



**FSA25-VEH23.0: Heavy Trucks and Buses
Item Group Specifications**

control, pump clutch, pump start/stop



FSA25-VEH23.0: Heavy Trucks and Buses Item Group Specifications

Utility Truck: 33,000 lbs. GVWR 4x4, Digger Derrick

This unit will meet all local, state, and federal standards associated with this type of vehicle and will be designed and constructed in accordance with current industry and engineering standards applicable and accepted for structural and hydraulic design.

FSA Item Group Description

- Complete ready-to-work unit.
- Standard manufacturer equipment and specifications, plus 2 keys and/or fobs (if not included).
- Make: Truck with mounted Terex Commander 4047 Digger Derrick Device, or equal
- Engine: Minimum 250 hp diesel engine, 6-cylinder, 660 lbs./ft
- GVWR: 33,000 lbs.
- Transmission: Allison 3500 RDS w/ Power Take-Off (PTO), pushbutton electronic shift control, synthetic transmission fluid
- Transfer Case: 2-speed, synthetic lube, oil cooler
- Front Driving Axle: 14,000 lbs. front drive axle w/ synthetic lube, setback axle
- Rear Axle: 21,000 lbs. rear drive axle, synthetic lube, driver-controlled differential lock
- Frame: Frame yield 50,000 psi , RBM 900,000 in/lbs., section modulus 18.0"
- Wheelbase: 190", CA 124"
- Steering: Power steering w/ see-through reservoir
- Brakes: ABS air brakes w/ automatic slack adjusters, frame-mounted air dryer, and pull cables on reservoir drains, w/ air connections, glad hands at rear of truck frame for trailers, trailer brake controller mounted in truck cab
- Front Suspension: 12,000 lbs., shock absorbers
- Rear Suspension: 21,000 lbs.
- Wheels: Steel, hub piloted
- Tires: 12R-22.5 16 ply radial
- Chassis Equipment: 50 gal fuel tank minimum, front tow hooks, front mudflaps
- Cab Exterior: air cab mounting, grab handles, air horn, heated west coast mirrors w/ convex mirrors, tinted glass, LED lights, back-up alarm
- Cab Interior: electric windows and electric door locks, A/C and heat, fire extinguisher, triangle reflector set, driver air ride high back seat, non-suspension passenger seat, sun visors, doors and ignition keyed alike, gauges for coolant, oil pressure, air, fuel, AM/FM radio, trailer hand control brake valve, intermittent windshield wipers and washer, electric brake control, tilt/telescope steering column, cruise control
- Color: White

Mounted Body

- Mounted Body: standard manufacturers line body, approximately 174" long x 46" high x 94" wide
 - Compartment Sizes:
 - Streetside- 3 vertical compartments approximately 30" wide x 46" deep x 18" high; 1 horizontal compartment approximately 54" wide x 24" high x 18" deep; 1 vertical
-



FSA25-VEH23.0: Heavy Trucks and Buses Item Group Specifications

- compartment approximately 24" wide x 46" wide x 18" deep
- Curbside- 2 vertical compartments approximately 30" wide x 46" high x 18" deep; 1 horizontal compartment approximately 54" wide x 24" high x 18" deep; 1 vertical compartment 24" wide x 46" high x 18" deep
- Compartments: Doors keyed alike, rotary style latches, top painted w/nonskid, adjustable shelves w/ dividers and lighting in all compartments
- Curbside Access: 30" wide, grip strut steps, cable type flexible step at bottom, grab handles,
- Outrigger pad holders, wheel chocks storage, included in compartmentation
- Body Floor: painted w/nonskid, cargo tiedowns
- Hydraulic hose reel installed on body
- Tail Shelf on Rear: Approximately 30" wide x 94" wide, flexible cable type steps, grab handles
- Pintle Hitch: 15 ton pintle hitch, safety chain eyes, glad hands at rear, 7-prong trailer socket
- Rear Bumper: ICC rear step bumper
- Steps: Steps to platform from body
- Strobe Lights: Amber strobe, 6" diameter
- Mud Flaps: Rear mount mudflaps
- Color: White, matching truck

Approximate Digger/Derrick Device Capacities and Dimensional Data

- Sheave Height: Intermediate boom extended 38.6' maximum elevation; w/ upper boom extended 47.4' maximum elevation
- Load Radius: 28.5' from c/l of rotation at 0 degree w/ intermediate boom extended; 37.5' from c/l of rotation at 0 degree w/ upper boom extended
- Lift Capacities: Maximum elevation 24,750 lbs. w/ all booms retracted; at 10' radius 11,000 lbs.
- Work Zone Capacities: Median digging radius 20.5'; digging capacity at median radius 2,542 lbs.; lift capacity at median radius 4,524 lbs.
- Elevation: +80 degrees above horizontal to -20 degrees below horizontal
- Turntable: Self-locking worm gear, bi-directional motor, unrestricted and continuous rotation
- Turntable Winch: Transferable pole buddy assembly (from intermediate boom to upper boom), 15,000 lbs. winch bare drum capacity, worm gear type, hydraulic counterbalance valve, two block
- Pole Guide: Installed on transferable pole buddy assembly, interlock system
- Pole Claw: Circular design for up to 23" in diameter
- 2-Speed Digger: 12,000 ft/lbs., hydraulic shift, planetary type
- LH Auger Storage and Digger Hanger: Box section type, hydraulic auger release, self-latching auger catch, stowage bracket, nylon strap for auger rollup, digger storage protection to protect auger storage cable
- Auger: 18" diameter, 104" length, carbide tooth, 2-5/8" solid hex type w/adjustment holes, rollup dish
- Hydraulic system: Open center type, permanent type hose fittings, 50 gal reservoir, relief valves protection for all derrick, digger and winch circuits, automatic Load Limiter Overload Protection to disable functions in an overload condition



FSA25-VEH23.0: Heavy Trucks and Buses Item Group Specifications

- Lower Boom: Steel box type, double lift cylinders
 - Intermediate Boom: Steel box type, holding valves on extend and retract
 - Upper Boom: Filament wound fiberglass, boom rest w/ tie down, non-metallic rollers. Fiberglass boom will be tested and rated for line voltage up to and including 46 kV. Documentation will be provided w/unit.
 - Upper Command Post: adjustable cushioned operator seat w/side rails
 - Upper Controls: Single stick type for rotation, boom elevation, and intermediate boom, individual control for upper boom, engine stop/start, hydraulic system gauge, horn, foot throttle
 - Outriggers: A-frame outriggers, swivel type stabilizer pads, 6" club feet, poly outrigger pads, pad holder
 - Ground Cable: 2/0 ground cable per ASTM F855-04, 50', ground clamp, 3-point ground system, 3 ground lugs, 2 ferrules, cable bracket; purchaser must verify this ground system meets their entity's requirements
 - Outrigger Controls: located at rear, each side for view of outrigger placement, outrigger interlock, auxiliary tool outlets, motion alarm, engine stop/start
 - Wheel Chocks: Rubber wheel chocks, w/ storage well on mounted body
 - Strobes: 6" strobe lights
 - Front Winch and Bumper: 20,000 lbs. capacity hydraulic front winch, extended shaft to curb side, roller assembly, 200' of ½" wire rope, winch control in cab and front bumper, winch bumper rated for pulling capacity w/ tool box
 - Color: White, matching truck and mounted body
-



**FSA25-VEH23.0: Heavy Trucks and Buses
Item Group Specifications**

** Revised Specification Group. Tilt Cab Specification split into two weight classes.*

*** Indicates new item group.*





**FSA25-VEH23.0: Heavy Trucks and Buses
Item Group Specifications**

Buses Electric: 19 to 20 Passenger Capacity Range, Van-Type Cutaway Chassis

FSA Item Group Description

- Electric Motor: 160 kW, 215 hp minimum
- Batteries: 68 kW minimum
- GVWR: 14,500 lbs. (approximate, sized to meet passenger capacity)
- Passenger Seating: Seating for 19 passengers minimum



**FSA25-VEH23.0: Heavy Trucks and Buses
Item Group Specifications**

Buses Electric: 20 to 52 Passenger Capacity Range, Conventional-Type Chassis

FSA Item Group Description

- Electric Motor: 230 kW, 315 hp minimum
- Batteries: 155 kW battery capacity minimum
- GVWR: 23,500 lbs. (approximate, sized to meet passenger capacity)
- Passenger Seating: Seating for 20 passengers minimum



**FSA25-VEH23.0: Heavy Trucks and Buses
Item Group Specifications**

Buses Electric: 44 To 80 Passenger Capacity Range, Commercial-Type Chassis

FSA Item Group Description

- Electric Motor: 230 kW, 315 hp
- Batteries: 155 kW battery capacity (approximate)
- GVWR: 36,000 lbs. (approximate, sized to meet passenger capacity)
- Passenger Seating: Seating for 44 passengers minimum



FSA25-VEH23.0: Heavy Trucks and Buses Item Group Specifications

Utility Truck: 33,000 lbs. GVWR 4x4, Mounted Aerial Device

This unit will meet all local, state, and federal standards associated with this type of vehicle and will be designed and constructed in accordance with current industry and engineering standards applicable and accepted for structural and hydraulic design.

FSA Item Group Description:

- Complete ready-to-work unit.
- Standard manufacturer equipment and specifications, plus 2 keys and/or fobs (if not included).
- Make: Truck w/ mounted Terex Optima TC-55 Aerial Device or equal
- Engine: Minimum 250 hp diesel engine, 6-cylinder, 660 lbs./ft
- GVWR: 33,000 lbs.
- Transmission: Allison 3500 RDA w/ Power Take-Off (PTO), pushbutton electronic shift control, synthetic transmission fluid
- Transfer Case: 2-speed, synthetic lube
- Front Driving Axle: 14,000 lbs. front drive axle, w/ synthetic lube, setback axle
- Rear Axle: 21,000 lbs. rear drive axle, synthetic lube, driver controlled differential lock,
- Frame: Frame yield 50,000 psi, RBM 900,000 in/lbs., section modulus 18.0"
- Wheelbase: 190", CA 124"
- Steering: Power steering, with see-through reservoir
- Brakes: ABS air brakes, w/ automatic slack adjusters, frame-mounted air dryer, and pull cables on reservoir drains w/ air connections, glad hands at rear of truck frame for trailers
- Front Suspension: 12,000 lbs., shock absorber
- Rear Suspension: 21,000 lbs.
- Wheels: Steel, hub piloted,
- Tires: 12R-22.5 16 ply radial
- Chassis Equipment: 50 gal fuel tank minimum, front tow hooks, steel front bumper, front mudflaps
- Cab Exterior: Air cab mounting, grab handles, air horn, heated west coast mirrors w/convex mirrors, tinted glass, LED lights, back-up alarm
- Cab Interior: Electric windows and electric door locks, A/C and heat, fire extinguisher, triangle reflector set, driver air ride high back seat, non-suspension passenger seat, sun visors, doors and ignition keyed alike, gauges for coolant, oil pressure, air, fuel, AM/FM radio, trailer hand control brake valve, intermittent windshield wipers and washer, electric brake control, tilt/telescope steering column, cruise control
- Color: White

Mounted Body

- Mounted Body: Standard manufacturers line body, approximately 168" long x 46" high x 94" wide
 - Compartment Sizes:
-



FSA25-VEH23.0: Heavy Trucks and Buses Item Group Specifications

- Streetside- 3 vertical compartments approximately 30" wide x 46" deep x 18" high; 1 horizontal compartment approximately 54" wide x 24" high x 18" deep; 1 vertical compartment approximately 24" wide x 46" wide x 18" deep
- Curbside- 2 vertical compartments approximately 30" wide x 46" high x 18" deep; 1 horizontal compartment approximately 54" wide x 24" high x 18" deep; 1 vertical compartment approximately 24" wide x 46" high x 18" deep
- Compartments: Doors keyed alike, rotary style latches, top painted w/ nonskid, adjustable shelves w/ dividers and compartment interior lighting
- Curbside Access: 30" wide, grip strut steps, cable type flexible step at bottom, grab handles
- Body Floor: Painted w/ nonskid, cargo tiedowns
- Tail Shelf on Rear: Approximately 30" wide x 94" wide, flexible cable type steps, grab handles
- Pintle Hitch: 15 ton pintle hitch, safety chain eyes, glad hands at rear, 7-prong trailer socket
- Rear Bumper: ICC rear step bumper
- Steps: Steps to platform from body
- Strobe Lights: Amber strobe, 6" diameter
- Mud Flaps: Rear mount mudflaps
- Color: White, matching truck

Approximate Aerial Device Dimensional Data:

- Bottom of Platform: 55'
- Working Height: 60'
- Side Reach: 42.8'
- Bottom of Platform to Ground: 1.3'
- Lower Boom Articulation to Ground: 116 degrees in non over center position
- Platform Rotator: 105 degrees of forward rotation
- Turntable: Self-locking worm gear, bi-directional motor, unrestricted and continuous rotation
- Hydraulic System: Open center type, permanent type hose fittings, 50 gal reservoir, dual tool outlets at platform w/ flow control
- Aerial Device Dielectrically Tested and Certification: Aerial device will be a Category C machine in accordance and is dielectrically tested and rated on systems up to 46 kV phase to phase as per ANSI/SIA A92.2-2015
- Lower Boom: Filament wound fiberglass w/ insulating gap
- Upper Boom: Filament wound tapered w/ insulating gap, boom rest w/ cam type tie down
- Platform: Side mounted, fiberglass, 24" x 48" x 42", curbside, w/ access steps slip resistant type, hydraulic leveling , 700 lbs. capacity, padded platform rest, insulated platform liner tested at 50 kV AC, 2 safety harness w /lanyard and fall arrest, waterproof platform cover
- Load Jib: Hydraulic extension, infinite positioning -20 to +105 degrees, 2,000 lbs. hydraulic winch w/ 75' of load line, load chart

Exhibit G - Impact of Section 232 Federal Tariff - effective 11-1-25

From: Chris Harris
To: [Becky N. Thomas](mailto:Becky_N.Thomas)
Subject: FW: Impact of new Section 232 Federal Tariff announcement Oct. 17th, 2025 and effective Nov. 1st, 2025 on class 3-8 trucks
Date: Thursday, February 19, 2026 4:56:09 PM
Attachments: [image001.png](#)
[image002.png](#)
[image003.png](#)
[G-5630H_International_Trucks_Tariff-Driven_Surcharge_and_Pricing_10-24-25.pdf](#)
[Tariff_Related_Adjustments_to_FSA25-23.0_Sun_State_International_11-5-25.xlsx](#)

This Message Is From an External Sender

This message came from outside your organization.

[Report Suspicious](#)

Good afternoon, Tom

Please see email below to Megan Taber from the Florida Sheriffs Association.

Documentation provided as to the price variance that you see on the final awarded bid packet for the **FSA25-VEH23.0:Heavy Trucks & Buses**. Vs the link for Item #77 itself. There was a price increase after the bid opened on 10/1/2025. That price increased on 11/5/2025. We're not sure as to why the FSA Full Award Packet itself was not updated properly, that is something all vendors will need to address with FSA. Base price of Item #77 did indeed increase from \$136,697 to \$142,997 a difference of \$6300.00.

<https://flsheriffs.org/how-we-serve/purchasing-program/cooperative-purchasing-program/purchaser-resources/full-award-packets-for-all-contracts/>

<https://www.myvendorlink.com/external/award?s=181132&i=77>

If you have any further questions, please feel free to let me know.

Thank you.

Chris Harris

Let's Get You Going!

Truck Sales Representative
Sun State International Trucks LLC
6020 Adamo Dr Tampa FL 33619
chris.harris@sunstateintl.com
Phone: 813-621-1331 x1018
Mobile: 813-760-8550



<https://www.sunstateintl.com>

Disclaimer Confidentiality Notice: This email and its contents may contain information that is privileged, confidential, proprietary or otherwise protected by law. If you are not the intended recipient, please do not disclose or use the information. If you have received this email in error, please notify the sender and delete it immediately. Sun State is not liable for any loss or damage arising in any way from this message or its attachments and accepts no responsibility for personal emails, or emails unconnected with the company's business.

From: Dave Metcalf <Dave.Metcalf@sunstateintl.com>

Sent: Thursday, February 19, 2026 4:26 PM

To: Chris Harris <chris.harris@sunstateintl.com>

Subject: Impact of new Section 232 Federal Tariff announcement Oct. 17th, 2025 and effective Nov. 1st, 2025 on class 3-8 trucks

Chris, see below.

Feel free forward this to Pinellas County.

Dave Metcalf

Let's Get You Going!

Truck Specification Specialist
Sun State International Trucks LLC
6020 Adamo Dr Tampa FL 33619
Dave.Metcalf@sunstateintl.com
Phone: 813-621-1331 x1011
Mobile: 813-382-1936



<https://www.sunstateintl.com>

Disclaimer Confidentiality Notice: This email and its contents may contain information that is privileged, confidential, proprietary or otherwise protected by law. If you are not the intended recipient, please do not disclose or use the information. If you have received this email in error, please notify the sender and delete it immediately. Sun State is not liable for any loss or damage arising in any way from this message or its attachments and accepts no responsibility for personal emails, or emails unconnected with the company's business.

From: Dave Metcalf

Sent: Wednesday, November 5, 2025 1:35 PM

To: Megan Taber <mtaber@flsheriffs.org>; FSA Cooperative Purchasing Program <cpp@flsheriffs.org>

Subject: Impact of new Section 232 Federal Tariff announcement Oct. 17th, 2025 and effective Nov. 1st, 2025 on class 3-8 trucks

Megan/ CPP Team,

The announcement below was released by the White House on Oct. 17th has created considerable complications for our 2026 calendar year production truck pricing that we have established on the FSA25-VEH23.0 Bid.

President Trump announced a 25% tariff on imported medium- and heavy-duty trucks (Class 3 to 8) and truck parts, which takes effect on November 1, 2025. The tariff is intended to protect U.S. manufacturing and is justified by national security concerns. Vehicles that qualify for preferential treatment under the United States-Mexico-Canada Agreement (USMCA) will be taxed only on the value of their non-U.S. content.

Details of the truck tariff

- **Tariff rate:** 25% ad valorem duty on medium- and heavy-duty trucks and truck parts.
- **Effective date:** November 1, 2025.
- **Covered vehicles:** Class 3 to 8 trucks, including large pickup trucks, moving trucks, cargo trucks, dump trucks, and 18-wheeler tractors.
- **Covered parts:** Key parts such as engines, transmissions, tires, and chassis are also subject to the tariff.
- **USMCA carve-out:** Trucks and parts that qualify for preferential treatment under the USMCA will be taxed only on the value of their non-U.S. content.
- **Justification:** The tariffs are intended to protect U.S. truck manufacturers from unfair competition and to support national security.
- **Additional relief:** The administration has also extended an existing 3.75% tariff relief credit for U.S.-assembled vehicles through 2030.

What does this mean?

The 1st file attached was released by International on Friday 10/24 and details the tariff related cost increases to our International vehicles for the 2026 calendar year. To keep it simple, **the new tariffs will increase the cost of our trucks built in 2026 by \$5,000 per medium duty vehicle (Items 54 & 61), and \$6,300 for each heavy-duty vehicle (Items 68, 69, 76 & 77).**

The current tariff related costs due to the 25% steel & aluminum tariffs imposed earlier this year is \$2,000 on medium-duty trucks and \$3,200 on heavy-duty trucks which was already included in our current pricing.

The combination of these prior tariffs and the newly imposed tariffs effective Nov. 1st raise the total tariff impact to \$7,000 per medium-duty vehicle (**thus the \$5,000 per unit increase**) and \$9,500 per heavy-duty vehicle (**thus the \$6,300 per unit increase**).

The snippet below is from the letter attached from International Motors to its U.S. dealer network that was released on 10/24/25.

- **Units ordered on or after November 1, 2025, and built in 2026**
OR
Units ordered between October 24 and October 31, 2025, and built on or after April 1, 2026

o The following tariff surcharges will apply, to be reflected on the factory invoice:

International® Model	Tariff Surcharge (Per Unit)
International® MV™ Series models	\$7,000
International® HV™ Series Medium Duty models	
International® HV™ Series Heavy Duty models	\$9,500

International® HX® Series models	
International® RH™, LT® Series models	
International® CV™ Series models	\$1,400
International® eMV™ Series models	TBD

I expect that you have or will be contacted by the other International dealers on the bid regarding this (Cumberland International and Rechten International), but how the tariffs impact us is that we will have to increase the base price on the trucks we currently have on the bid by the following amounts.

Model	Item#	FSA25-VEH23.0 Current Pricing	Tariff Related Increase	New Base Price	
CV 4x2	28	\$68,825.00	\$0.00	\$68,825.00	No Change
CV 4x4	41	\$72,755.00	\$0.00	\$72,755.00	No Change
eMV	20	\$283,820.00	TBD	\$283,820.00	TBD
HV615 6x4 Tractor	68	\$127,619.00	\$6,300.00	\$133,919.00	
HV615 6x4 Truck	76	\$124,428.00	\$6,300.00	\$130,728.00	
HX620 6x4 Tractor	69	\$138,995.00	\$6,300.00	\$145,295.00	
HX620 6x4 Truck	77	\$136,697.00	\$6,300.00	\$142,997.00	
MV 25,500 GVW	54	\$86,464.00	\$5,000.00	\$91,464.00	
MV 30,000 GVW	61	\$87,875.00	\$5,000.00	\$92,875.00	

The above figures are included in the 2nd file attached, the excel spreadsheet.

Please advise as to how we can approach this unfortunate situation.

Thanks,