

RESOLUTION NO. 22- 53

SECOND RESOLUTION DETERMINING THE NECESSITY TO CONSTRUCT BRIDGE AND DRAINAGE IMPROVEMENTS TO BECKETT BRIDGE AND RIVERSIDE DRIVE, AND DIRECTING THE CONDEMNATION OF THE NECESSARY PROPERTIES AND PROPERTY RIGHTS REQUIRED FOR CONSTRUCTION

WHEREAS, the Board of County Commissioners of Pinellas County, Florida (“Board”) adopted Resolution No. 22-25 on April 12, 2022, that among other things found that it is necessary to acquire specified interests in real properties identified within the attachments to that Resolution; and

WHEREAS, further survey and engineering work have determined that minor modification to the parcels and interests to be acquired are necessary; and

WHEREAS, it has been determined that one impacted tree area had been mislocated, and there was opportunity to reduce necessary property interests in a couple other areas; and

WHEREAS, except as specifically modified herein, the statements, findings and conclusions of Resolution No. 22-25 are intended to remain in full force and effect; and

WHEREAS, the Board is empowered under Chapters 73, 74, and 127 of Florida Statutes, to exercise the power of eminent domain and acquire such property rights as are deemed necessary by this Board for the public purpose of the construction and future maintenance of the Beckett Bridge and drainage improvements to Riverside Drive projects (together hereinafter referred to as the “Project”); and

WHEREAS, the Board has considered engineering analysis and workshop presentations on prior occasions as reflected in the memorandum from the County Administrator as attached to Resolution 22-25 and that memorandum is incorporated herein by reference, and has determined the necessity of acquiring certain properties and property rights only after considering alternative designs, safety factors, environmental considerations, costs of the Project, and long-range area planning; and

WHEREAS, all conditions precedent to the exercise of eminent domain have been performed or have occurred, or will be performed prior to the filing of any eminent domain litigation; and

WHEREAS, the Board intends to add the property interests needed and adjust the property interests to be acquired that can be minimized as reflected herein.

NOW, THEREFORE BE IT RESOLVED by the Board of County Commissioners of Pinellas County, Florida duly assembled this 19th day of July, 2022 that this Board finds it necessary and in the public interest to construct the roadway and drainage improvements in accordance with the Project construction plans as may be amended to correct the parcels necessary to be acquired as reflected herein.

BE IT FURTHER RESOLVED that the Board commits itself to the particular use and extent of the property to be taken as reflected herein to be used as reflected in the Project construction plans.

BE IT FURTHER RESOLVED that the Board finds it necessary to acquire the specified interests in the following described parcels (Exhibits A-G), in order to construct the Project as contemplated herein in accordance with said Project construction plans:

Parcel Number: P706A-R1 (Revision to correct location of previous parcel P706 Part A) – Temporary Construction Easement (“TCE”)

Parcel Number: P706B-R1 (Revision to reduce area of previous parcel P706 Part B) - TCE

Parcel Number: P706C-R1 (Revision to reduce area of previous parcel P706 Part C) - TCE

Parcel Number: P706D-R2 (Revision to reduce area of previous parcel P706 Part D-R1) - TCE

Parcel Number: P706E - (Revision to reduce area of previous parcel P706 Part D-R1) - TCE

Parcel Number: P706F (Revision to reduce area of previous parcel P706 Part D-R1) - TCE

Parcel Number: P706G (Revision to reduce area of previous parcel P706 Part B) -TCE

BE IT FURTHER RESOLVED that except as provided herein, the parcels needed and determinations made in Resolution 22-25 remain in full force and effect.

BE IT FURTHER RESOLVED that the County Attorney is hereby authorized and directed to acquire said parcels by negotiation, or failing voluntary sale by the owners, condemnation for the purposes aforesaid.

BE IT FURTHER RESOLVED that it is necessary to take said specified interests in lands prior to entry of final judgment in the eminent domain proceedings herein authorized.

BE IT FURTHER RESOLVED that this Resolution be made a part of the minutes of the proceedings of this Board, and that a certified copy thereof be filed for recording in the Public Records of Pinellas County, Florida.

Commissioner Long offered the foregoing Resolution and moved its adoption, which was seconded by Commissioner Gerard, and upon roll call the vote was:

AYES: Justice, Long, Eggers, Flowers, Gerard, and Seel.

NAYS:

ABSENT AND NOT VOTING: Peters.

APPROVED AS TO FORM

By: Donald S. Crowell
Office of the County Attorney

Right of Way Needs Memorandum
Beckett Bridge Replacement & Riverside Drive Stormwater Improvements
PID 001037A, 001037B

PID 001037A - Beckett Bridge over Whitcomb Bayou Replacement, Tarpon Springs Florida

PID 001037B - Riverside Drive and N. Spring Blvd. Drainage Improvements (CPA No. 421821, Work Assignment No. 4, SPO No. 432784)

Purpose of the Project

The purpose of the project is to replace the functionally obsolete and structurally deficient existing low-level bascule bridge with a new low-level bascule bridge. In addition, drainage improvements along Riverside Drive/Spring Blvd will be implemented to reduce roadway flooding west of the bridge.

Chronology

Beckett Bridge Replacement PD&E Study

01/03/2012 The Board of County Commissioners (BCC) executed an Agreement to retain an engineering consultant firm to conduct a Project Development and Environment (PD&E) study in coordination with the Florida Department of Transportation to evaluate alternatives for the replacement of the Beckett Bridge over Whitcomb Bayou in Tarpon Springs, Pinellas County, Florida.

03/13/2012 A project "Kick-Off" presentation was made to introduce the project at a regularly scheduled BCC meeting. Invitations to the meeting were distributed to all federal, State and local government officials; Pinellas County and City of Tarpon Springs staff; and FDOT.

09/13/2012 Pinellas County hosted a coordination meeting with the City of Tarpon Springs Public Works Director and City Engineering Projects Supervisor. Alternatives developed to date were presented and discussed. Strategies to involve the local communities and City officials and staff were discussed.

10/15/2012 County staff, with the assistance of the County's engineering consultant, presented the alternatives evaluated during the study to date to the MPO Pedestrian Transportation Advisory Committee to solicit input and comments about the project.

10/17/2012 County staff, with the assistance of the County's engineering consultant, presented the alternatives evaluated to date to the Tarpon Springs Yacht Club Board to solicit input and comments about the project.

10/22/2012 County staff, with the assistance of the County's engineering consultant, presented the alternatives evaluated during the study to date to the MPO Bicycle Advisory Committee to solicit input and comments about the project.

10/24/2012 County staff, with the assistance of the County's engineering consultant presented the alternatives evaluated during the study to date to the MPO Technical Coordinating Committee to solicit input and comments about the project.

Right of Way Needs Memorandum
Beckett Bridge Replacement & Riverside Drive Stormwater Improvements
PID 001037A, 001037B

10/25/2012 County staff, with the assistance of the County's engineering consultant presented the alternatives evaluated during the study to date to the MPO Citizens Advisory Committee to solicit input and comments about the project.

10/29/2012 County staff, with the assistance of the County's engineering consultant, hosted a meeting to discuss alternatives developed and evaluated with the Cultural Resources Committee (CRC) that was established to address potential impacts to the historic bridge as required by Section 106, National Historic Preservation Act and other related federal and state regulations ("Section 106"). This committee included representatives of the Federal Highway Administration (FHWA), State Historic Preservation Officer (SHPO), FDOT, Tarpon Springs Historic Society, U.S. Coast Guard (USCG), City of Tarpon Springs, the Tarpon Springs Yacht Club and Pinellas County. The existing Beckett Bridge was determined to be eligible for listing in the National Register of Historic Places. The purpose of this meeting was to provide an opportunity for stakeholders to participate in the Section 106 process and discuss alternatives considered for the bridge.

10/30/2012 County staff, with the assistance of the County's engineering consultant, presented alternatives scheduled to be shown to the public at the January 2013 Public Alternatives Workshop to the BCC. The BCC authorized County staff to proceed with the Public Alternatives Workshop.

11/14/2012 County staff, with the assistance of the County's engineering consultant, presented alternatives scheduled to be shown to the public at the January 2013 Public Alternatives Workshop to the Pinellas County Metropolitan Planning Organization (MPO) Board to solicit input and comments.

11/20/2012 County staff, with the assistance of the County's engineering consultant, made a presentation about the project to the City of Tarpon Springs City Commission to solicit input about the project.

11/21/2012 County staff, with the assistance of the County's engineering consultant, made a presentation about the alternatives evaluated to date to the Tarpon Springs Chamber of Commerce. The purpose of this meeting was to solicit input and comments about the project.

01/31/2012 County staff, with the assistance of the County's engineering consultant, made a presentation about the alternatives evaluated to date at the Tarpon Springs Rotary Club meeting to solicit input and comments about the project.

01/23/2013 The County hosted a Public Alternatives Workshop to present the alternatives evaluated and to provide an opportunity for community input. Invitations were mailed to approximately 1,200 property owners and Approximately 120 persons signed in at the meeting.

03/13/2013 County staff, with the assistance of the County's engineering consultant, hosted a second CRC meeting. At this meeting, public comments received at the Public Alternatives Workshop were presented. Potential effects to the historic bridge and discussion of possible mitigation and minimization measures were discussed. As a result of this meeting, the project team agreed to investigate three additional rehabilitation concepts that would provide safer and wider sidewalks.

10/01/2013 County staff, with the assistance of the County's engineering consultant, made a presentation to the Tarpon Springs City Commission to update them on the status of the PD&E study.

Right of Way Needs Memorandum
Beckett Bridge Replacement & Riverside Drive Stormwater Improvements
PID 001037A, 001037B

10/22/2013 County staff, with the assistance of the County's engineering consultant, made a presentation to the BCC that included information about the Recommended Alternative scheduled to be presented at the February 2014 Public Hearing. The Pinellas County BCC approved the Recommended Alternative to replace the existing bridge with a new movable bridge at this meeting.

10/23/2013 County staff, with the assistance of the County's engineering consultant, made a presentation to the MPO Technical Coordinating Committee that included information about the Recommended Alternative scheduled to be presented at the February 2014 Public Hearing.

10/25/2013 County staff, with the assistance of the County's engineering consultant, made a presentation to the MPO Citizens Advisory Committee that included information about the Recommended Alternative scheduled to be presented at the February 2014 Public Hearing.

11/13/2013 County staff, with the assistance of the County's engineering consultant, made a presentation to the MPO Board that included information about the Recommended Alternative scheduled to be presented at the February 2014 Public Hearing.

12/18/2013 County staff, with the assistance of the County's engineering consultant, made a presentation to the Tarpon Springs Yacht Club Board that included information about the Recommended Alternative scheduled to be presented at the February 2014 Public Hearing.

01/16/2014 County staff, with the assistance of the County's engineering consultant, made a presentation to the Tarpon Springs Historical Society that included information about the Recommended Alternative scheduled to be presented at the February 2014 Public Hearing.

02/26/2014 County staff with the assistance of the County's engineering consultant held a Public Hearing in accordance with requirements of the National Environmental Policy Act (NEPA) to present information about the Recommended Alternative as well as other alternatives evaluated during the study.

04/15/2014 County staff with the assistance of the County's engineering consultant, made a presentation to the BCC which summarized the results of the February 2014 Public Hearing. The BCC confirmed and ratified their approval of the Recommended Alternative to move forward as the "Locally Preferred Alternative" and approved submitting the alternative to the FHWA for approval.

Beckett Bridge Design

12/07/2016 Pinellas County staff with the assistance of the County's engineering consultant held the first of four Aesthetic Committee Meetings. These meetings were a requirement of the Memorandum of Agreement between the United States Department of Transportation Federal Highway Administration and the Florida State Historic Preservation Office regarding Beckett Bridge (FDOT Bridge No. 154000).

03/01/2017 Pinellas County staff, with the assistance of the County's engineering consultant held the second of four Aesthetic Committee Meetings.

05/10/2017 Pinellas County staff with the assistance of the County's engineering consultant held the third of four Aesthetic Committee Meetings.

Right of Way Needs Memorandum
Beckett Bridge Replacement & Riverside Drive Stormwater Improvements
PID 001037A, 001037B

03/22/2018 Pinellas County staff with the assistance of the County's engineering consultant held the fourth (final) Aesthetic Committee Meeting.

09/11/2018 Standard Purchase Order Number 43284 for CPA no. 421821, Work Assignment was issued to Hardesty & Hanover, Inc. to conduct a study to evaluate and design stormwater improvements to reduce roadway flooding on Riverside Drive west of the Bridge.

04/16/2019 Pinellas County staff made a presentation to the Tarpon Springs Board of Commissioners. A concept to include construction of sidewalks and bicycle lanes on both sides of Riverside Drive west of the bridge was discussed. Acquisition of approximately 15 feet of property along the south side of Riverside Drive from Bayshore Mobile Home Park would be required for this concept. The additional right-of-way would also provide more space for construction staging and relocation of the City of Tarpon Springs major utilities.

08/19/21 Pinellas County staff presented the results of the four Aesthetics Committee Meetings at a BCC workshop.

Factors to be Considered by BCC in Passing a Resolution of Necessity:

Alternatives Considered to Replacement of the Existing Bridge

Alternative Corridors: Areas to the east and west of the bridge are densely developed. Accordingly, other corridors for construction of a new bridge would result in substantial impacts to adjacent properties and result in more impacts to the natural environment. A replacement bridge on the existing corridor will best serve the purpose and needs of the project.

Rehabilitation Alternatives Considered: Rehabilitation without widening the bridge was considered and determined not to be a viable alternative. Beckett Bridge was determined to be eligible for listing in the National Register of Historic Places by the SHPO in October 2012 during the PD&E study. Accordingly, SHPO requested evaluation of two additional rehabilitation alternatives. Ultimately, these additional rehabilitation alternatives were determined not to be viable alternatives.

Rehabilitation without widening – No pedestrian/bicycle facility improvements

- Only extends viable life 25-30 years
- Very narrow sidewalks remain

Rehabilitation with Widening - Two, 5'6" sidewalks, one on each side of bridge

- Existing piers do not have structural capacity for additional load
- Requires replacement of bascule span and piers
- 79% of replacement bridge cost

Rehabilitation with Widening - One wider sidewalk on one side of the bridge

- Existing piers do not have structural capacity for additional load
- High replacement costs

Right of Way Needs Memorandum
Beckett Bridge Replacement & Riverside Drive Stormwater Improvements
PID 001037A, 001037B

- Requires replacement of bascule spans and piers

Replacement Alternatives Considered (other than Preferred Alternative)

Mid-Level Fixed Bridge Alternatives – Two options were evaluated and determined not to be viable alternatives

- Substantial impacts to adjacent property owners, 3-5 residential relocations required
- Intersections of Pampas Avenue and Venetian Court with Riverside Drive/Spring Blvd. would be eliminated
- Substantial visual impacts to adjacent properties

Additional Alternatives Considered During Design

Acquisition of approximately 15 feet of property along the northern boundary of the Bay Shore Mobile Home Park and RV Park to accommodate construction of sidewalks and bicycle lanes on both sides of Riverside Drive from Chesapeake Drive to the Bridge was considered and evaluated in 2019. This alternative would require relocation of 16 mobile homes and 1 RV pad site. It was determined not to be a viable alternative because of the magnitude of impacts the Bayshore Mobile Home Park.

Safety

The existing bridge has reduced capacity due to ongoing deterioration and is classified as structurally deficient and functionally obsolete. The bridge is currently posted for legal loads limited to 12-ton Single Unit trucks and 15-ton combination trucks. The bridge is founded on Karst subsurface conditions with a portion of the bridge, including the bascule span and one approach span, located over a relict sinkhole. The foundations have a long history of vertical settlement and horizontal movement requiring major repairs. The continued settlement and movement require frequent monitoring, surveying inspections and maintenance.

Recent reevaluation (June 2021) of the bridge condition resulted in the National Bridge Inventory (NBI) substructure rating dropping from 6 (satisfactory condition) to 4 (poor condition) on a scale from 0 to 9. This reduction in rating will result in a Sufficiency Rating of 18.1 compared to 48.3 on a scale of 0-100. (Sufficiency Rating is a tool used by the Federal Highway Administration when allocating federal funds for bridge replacement).

There are no shoulders on the bridge. Bridge railings do not meet current standards for pedestrian safety or geometric and crash testing safety standards for vehicles. Approach guardrail and transitions and end treatments also do not meet current safety standards. Sidewalks on the bridge are only 2'2" wide and do not meet the requirements of the Americans with Disabilities Act.

The proposed new bridge will meet all current safety standards and provide enhanced bicycle and pedestrian facilities. The need for frequent repairs will be eliminated.

Environmental

The proposed bridge and roadway improvements will be constructed in compliance with all federal, state, and local environmental requirements.

Right of Way Needs Memorandum
Beckett Bridge Replacement & Riverside Drive Stormwater Improvements
PID 001037A, 001037B

The bridge has been determined to be eligible for listing in the National Register of Historic Places by the SHPO. All mitigation requirements of the Memorandum of Agreement, signed in January 2015 by SHPO, FDOT, FHWA and Pinellas County, will be met.

Pinellas County will comply with the current version of the US Fish and Wildlife Service (USFWS) and Florida Fish and Wildlife Conservation Commission (FWC) approved *Standard Manatee Construction Conditions* during all in-water construction phases of the project. The County has also committed to excluding blasting as a means for demolishing the bridge.

Pinellas County will comply with the National Marine Fisheries Service's *Sea Turtle and Smalltooth Sawfish Construction Conditions* and will require all construction workers to watch for listed species.

Pinellas County will coordinate with FWC for the removal of osprey nests on a utility pole within the construction area during the design and permitting phase of the project.

Costs

The proposed bridge replacement alternative was designed to minimize impacts to adjacent properties. Costs for acquisition of temporary and permanent easements are minimized to the maximum extent possible.

Long Range Planning

Forward Pinellas 2045 Long Range Transportation Plan adopted November 13, 2010 has identified replacement for the Beckett Bridge by 2045.

PINELLAS COUNTY
 PUBLIC WORKS
 SURVEY AND MAPPING DIVISION
 22211 U.S. HIGHWAY 19 N.
 CLEARWATER, FLORIDA 33765-2328



SECTION 11, TOWNSHIP 27 SOUTH, RANGE 15 EAST

DESCRIPTION

A rectangular shaped tract, being a portion of that certain parcel, as described in Official Records Book 6523, Page 2374, public records of Pinellas County, Florida, in Section 11, Township 27 South, Range 15 East, Pinellas County, Florida, being described as follows:

Commencing at the Southeast corner of Lot 1, E.M. SMITHS BAYOU SUBDIVISION REVISED, recorded in Plat Book 21, Page 63, public records of Pinellas County, Florida; thence N84°55'16"W, for a distance of 197.29 feet (N89°26'00"W 197.95 feet per Deed; N85°26"W, 198.23 feet per Plat) along the North Right-of-Way line of Riverside Drive; thence S02°57'14"W, for a distance of 40.03 feet (S02°24'36"W, 40.03 feet per Deed) to a point on the North line of the aforementioned parcel described in Official Records Book 6523, Page 2374, the same being the South Right-of-Way line of Riverside Drive; thence N89°10'16"W (N89°41'00"W per Deed) along said North line, for a distance of 99.97 feet to the POINT OF BEGINNING; thence S00°49'44"W, for a distance of 3.22 feet; thence N85°38'39"W, for a distance of 10.02 feet; thence N00°49'44"E, for a distance of 2.60 feet returning to the aforementioned North line of said parcel described in Official Records Book 6523, Page 2374; thence S89°10'16"E (N89°41'00"W per Deed) along said North line, for a distance of 10.00 feet to the POINT OF BEGINNING.

CONTAINING: 29 square feet or 0.001 acres, more or less.

SURVEYOR'S REPORT

1. BASIS OF BEARINGS: Bearings are based on the North Right of Way line of Riverside Drive as shown on the Specific Purpose Survey, SFN1525, prepared by Sue Scholpp, dated 10/20/2010, revised 1/10/2012, being N84°55'16"W.
2. Deed information shown hereon is in reference to the Warranty Deed recorded in Official Records Book 6523, Page 2374 of the public records of Pinellas County, Florida.
3. Plat information shown hereon is in reference to E.M. SMITHS BAYOU SUBDIVISION REVISED, recorded in Plat Book 21, Page 63 of the public records of Pinellas County.

Additions or deletions by other than the Professional Surveyor and Mapper in responsible charge are prohibited. Sketch and/or Description is invalid without the original signature and seal of the Professional Surveyor and Mapper

CALCULATED BY: RAC	The above Sketch and Land description was prepared under my supervision and is true and correct to the best of my knowledge and belief.
CHECKED BY: PS	By: Pinellas County Survey and Mapping Division
S.F.N.: 1673	DATE <u>5/4/2022</u> PENNY STANDRIDGE SIMONE, LAND SURVEYOR CERTIFICATE NUMBER: 5240 STATE OF FLORIDA, PHONE # (727) 464-8904

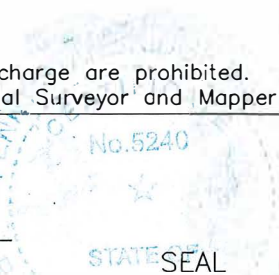

PINELLAS COUNTY
 PUBLIC WORKS
 SURVEY AND MAPPING DIVISION
 22211 U.S. HIGHWAY 19 N.
 CLEARWATER, FLORIDA 33765-2328



SECTION 11, TOWNSHIP 27 SOUTH, RANGE 15 EAST
 SKETCH - NOT A SURVEY

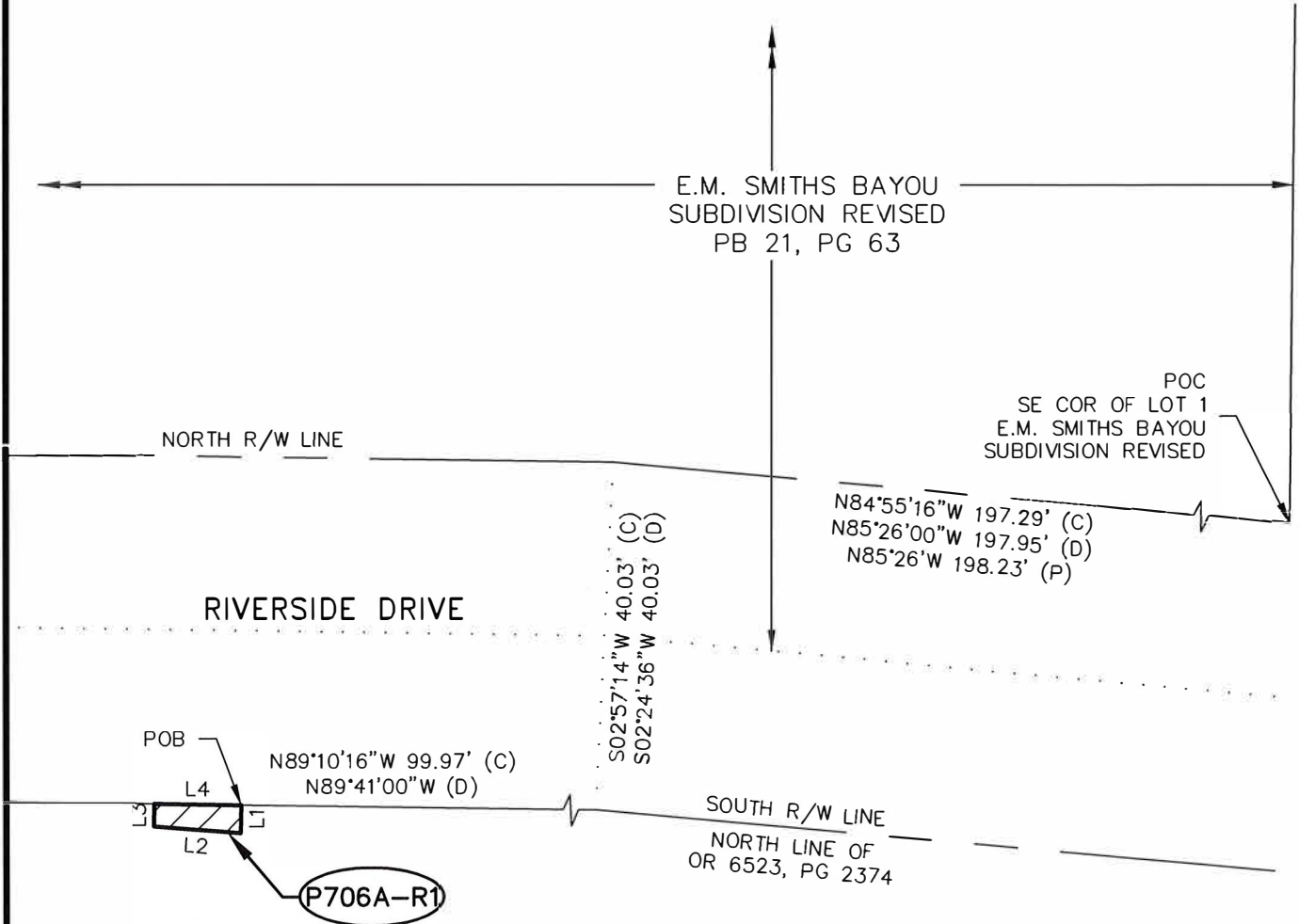

OR 6523
 PG 2374

CALCULATED BY:
 RAC
 CHECKED BY:
 PS
 S.F.N.:
 1673

LINE TABLE		
LINE #	BEARING	LENGTH
L1	S00°49'44"W	3.22'
L2	N85°38'39"W	10.02'
L3	N00°49'44"E	2.60'
L4	S89°10'16"E	10.00'

LEGEND	
(C)	CALCULATED DATA
(D)	DEED DATA
OR	OFFICIAL RECORDS BOOK
(P)	PLAT DATA
PB	PLAT BOOK
PG	PAGE
POB	POINT OF BEGINNING
POC	POINT OF COMMENCEMENT
R/W	RIGHT OF WAY

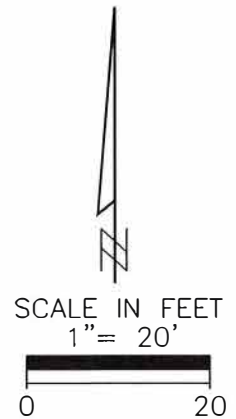



SECTION 11, TOWNSHIP 27 SOUTH, RANGE 15 EAST

DESCRIPTION

A rectangular shaped tract, being a portion of that certain parcel, as described in Official Records Book 6523, Page 2374, public records of Pinellas County, Florida, in Section 11, Township 27 South, Range 15 East, Pinellas County, Florida, being described as follows:

Commencing at the Southeast corner of Lot 1, E.M. SMITHS BAYOU SUBDIVISION REVISED, recorded in Plat Book 21, Page 63, public records of Pinellas County, Florida; thence N84°55'16"W, for a distance of 197.29 feet (N89°26'00"W 197.95 feet per Deed; N85°26'W, 198.23 feet per Plat) along the North Right-of-Way line of Riverside Drive; thence S02°57'14"W, for a distance of 40.03 feet (S02°24'36"W, 40.03 feet per Deed) to a point on the North line of the aforementioned parcel described in Official Records Book 6523, Page 2374, the same being the South Right-of-Way line of Riverside Drive; thence N89°10'16"W (N89°41'00"W per Deed) along said North line, for a distance of 18.47 feet to the POINT OF BEGINNING; thence S00°49'44"W, for a distance of 3.91 feet; thence N89°14'17"W, for a distance of 8.00 feet; thence N00°49'44"E, for a distance of 3.92 feet returning to the aforementioned North line of said parcel recorded in Official Records Book 6523, Page 2374; thence S89°10'16"E (S89°41'00"E per Deed) along said North line, for a distance of 8.00 feet to the POINT OF BEGINNING.

CONTAINING: 31 square feet or 0.001 acres, more or less.

SURVEYOR'S REPORT

1. BASIS OF BEARINGS: Bearings are based on the North Right of Way line of Riverside Drive as shown on the Specific Purpose Survey, SFN1525, prepared by Sue Scholpp, dated 10/20/2010, revised 1/10/2012, being N84°55'16"W.
2. Deed information shown hereon is in reference to the Warranty Deed recorded in Official Records Book 6523, Page 2374 of the public records of Pinellas County, Florida.
3. Plat information shown hereon is in reference to E.M. SMITHS BAYOU SUBDIVISION REVISED, recorded in Plat Book 21, Page 63 of the public records of Pinellas County.

Additions or deletions by other than the Professional Surveyor and Mapper in responsible charge are prohibited. Sketch and/or Description is invalid without the original signature and seal of the Professional Surveyor and Mapper.

CALCULATED BY: RAC	The above Sketch and Land description was prepared under my supervision and is true and correct to the best of my knowledge and belief.
CHECKED BY: PS	By: Pinellas County Survey and Mapping Division
S.F.N.: 1673	DATE <u>5/4/2022</u> PENNY STANDRIDGE SIMONE, LAND SURVEYOR CERTIFICATE NUMBER: 5240 STATE OF FLORIDA, PHONE # (727) 464-8904

STAT SEAL

PINELLAS COUNTY
 PUBLIC WORKS
 SURVEY AND MAPPING DIVISION
 22211 U.S. HIGHWAY 19 N.
 CLEARWATER, FLORIDA 33765-2328



SECTION 11, TOWNSHIP 27 SOUTH, RANGE 15 EAST
 SKETCH - NOT A SURVEY

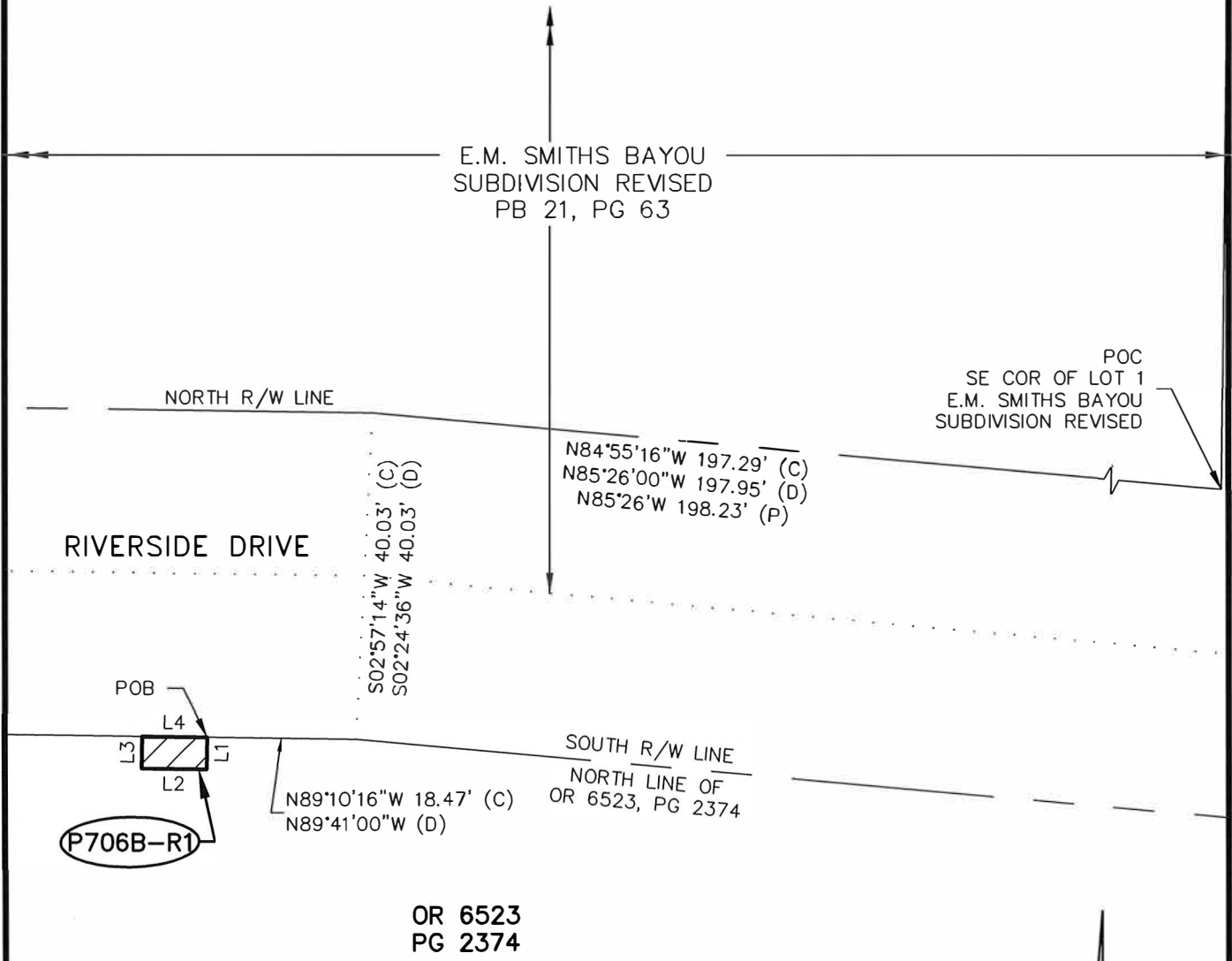

LINE TABLE		
LINE #	BEARING	LENGTH
L1	S00°49'44"W	3.91'
L2	N89°14'17"W	8.00'
L3	N00°49'44"E	3.92'
L4	S89°10'16"E	8.00'

LEGEND	
(C)	CALCULATED DATA
(D)	DEED DATA
OR	OFFICIAL RECORDS BOOK
(P)	PLAT DATA
PB	PLAT BOOK
PG	PAGE
POB	POINT OF BEGINNING
POC	POINT OF COMMENCEMENT
R/W	RIGHT OF WAY

CALCULATED BY:
 RAC
 CHECKED BY:
 PS
 S.F.N.:
 1673

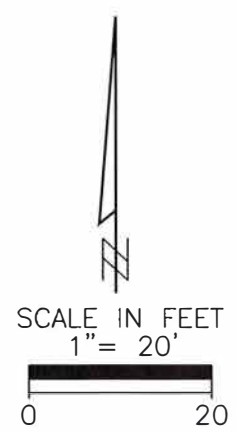

PINELLAS COUNTY
 PUBLIC WORKS
 SURVEY AND MAPPING DIVISION
 22211 U.S. HIGHWAY 19 N.
 CLEARWATER, FLORIDA 33765-2328



SECTION 11, TOWNSHIP 27 SOUTH, RANGE 15 EAST

DESCRIPTION

A rectangular shaped tract, being a portion of that certain parcel, as described in Official Records Book 6523, Page 2374, public records of Pinellas County, Florida, in Section 11, Township 27 South, Range 15 East, Pinellas County, Florida, being described as follows:

Commencing at the Southeast corner of Lot 1, E.M. SMITHS BAYOU SUBDIVISION REVISED, recorded in Plat Book 21, Page 63, public records of Pinellas County, Florida; thence N84°55'16"W, for a distance of 197.29 feet (N89°26'00"W 197.95 feet per Deed; N85°26'W, 198.23 feet per Plat) along the North Right-of-Way line of Riverside Drive; thence S02°57'14"W, for a distance of 40.03 feet (S02°24'36"W, 40.03 feet per Deed) to a point on the North line of the aforementioned parcel described in Official Records Book 6523, Page 2374, the same being the South Right-of-Way line of Riverside Drive; thence along said North line S84°55'16"E (S85°26'00"E per Deed), for a distance of 102.59 feet to the POINT OF BEGINNING; thence continue along said line S84°55'16"E (S85°26'00"E per Deed), for a distance of 10.01 feet; thence S05°04'44"W, for a distance of 7.12 feet; thence N83°24'28"W, for a distance of 10.01 feet; thence N05°04'44"E, for a distance of 6.86 feet to the POINT OF BEGINNING.

CONTAINING: 70 square feet or 0.002 acres, more or less.

SURVEYOR'S REPORT

1. BASIS OF BEARINGS: Bearings are based on the North Right of Way line of Riverside Drive as shown on the Specific Purpose Survey, SFN1525, prepared by Sue Scholpp, dated 10/20/2010, revised 1/10/2012, being N84°55'16"W.
2. Deed information shown hereon is in reference to the Warranty Deed recorded in Official Records Book 6523, Page 2374 of the public records of Pinellas County, Florida.
3. Plat information shown hereon is in reference to E.M. SMITHS BAYOU SUBDIVISION REVISED, recorded in Plat Book 21, Page 63 of the public records of Pinellas County.

Additions or deletions by other than the Professional Surveyor and Mapper in responsible charge are prohibited. Sketch and/or Description is invalid without the original signature and seal of the Professional Surveyor and Mapper.

CALCULATED BY: RAC	The above Sketch and Land description was prepared under my supervision and is true and correct to the best of my knowledge and belief.
CHECKED BY: PS	By: Pinellas County Survey and Mapping Division
S.F.N.: 1673	DATE <u>5/4/2022</u> PENNY STANDRIDGE SIMONE, LAND SURVEYOR CERTIFICATE NUMBER: 5240 STATE OF FLORIDA, PHONE # (727) 464-8904

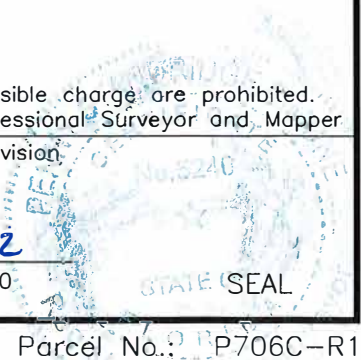



SECTION 11, TOWNSHIP 27 SOUTH, RANGE 15 EAST
 SKETCH - NOT A SURVEY

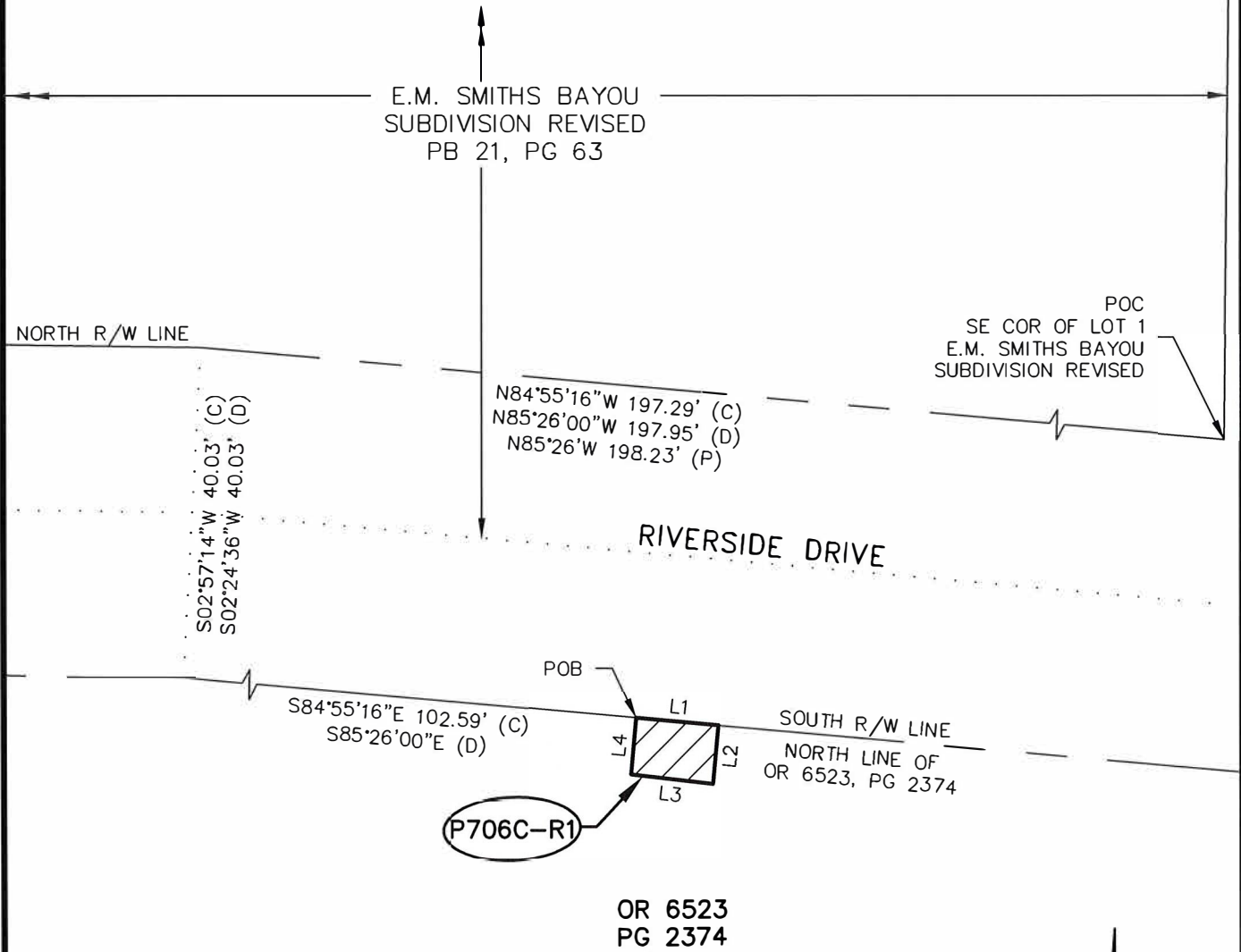

CALCULATED BY:
 RAC

CHECKED BY:
 PS

S.F.N.:
 1673

LINE TABLE			
LINE #	BEARING	LENGTH	
L1	S84°55'16"E	10.01'	
L2	S05°04'44"W	7.12'	
L3	N83°24'28"W	10.01'	
L4	N05°04'44"E	6.86'	

LEGEND	
(C)	CALCULATED DATA
(D)	DEED DATA
OR	OFFICIAL RECORDS BOOK
(P)	PLAT DATA
PB	PLAT BOOK
PG	PAGE
POB	POINT OF BEGINNING
POC	POINT OF COMMENCEMENT
R/W	RIGHT OF WAY

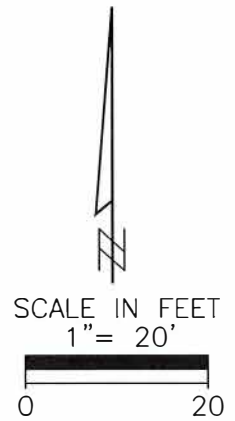

PINELLAS COUNTY
 PUBLIC WORKS
 SURVEY AND MAPPING DIVISION
 22211 U.S. HIGHWAY 19 N.
 CLEARWATER, FLORIDA 33765-2328



SECTION 11, TOWNSHIP 27 SOUTH, RANGE 15 EAST

DESCRIPTION

A portion of that certain parcel, as described in Official Records Book 6523, Page 2374, public records of Pinellas County, Florida, in Section 11, Township 27 South, Range 15 East, Pinellas County, Florida, being described as follows:

Commencing at the Southeast corner of Lot 1, E.M. SMITHS BAYOU SUBDIVISION REVISED, recorded in Plat Book 21, Page 63, public records of Pinellas County, Florida; thence N84°55'16"W, for a distance of 197.29 feet (N89°26'00"W 197.95 feet per Deed; N85°26'W, 198.23 feet per Plat) along the North Right-of-Way line of Riverside Drive; thence S02°57'14"W, for a distance of 40.03 feet (S02°24'36"W, 40.03 feet per Deed) to a point on the North line of the aforementioned parcel described in Official Records Book 6523, Page 2374, the same being the South Right-of-Way line of Riverside Drive; thence along said North line S84°55'16"E (S85°26'00"E per Deed), for a distance of 244.35 feet to the POINT OF BEGINNING; thence continue along said North line S84°55'16"E, for a distance of 95.40 feet; thence S05°04'44"W, for a distance of 5.00 feet; thence N84°55'17"W, for a distance of 21.87 feet; thence N79°02'45"W, for a distance of 22.07 feet; thence S54°31'43"W, for a distance of 13.46 feet; thence S08°15'32"W, for a distance of 13.53 feet; thence N84°55'16"W, for a distance of 25.93 feet; thence N08°10'29"W, for a distance of 18.04 feet; thence N82°20'51"W, for a distance of 10.54 feet; thence N05°04'44"E, for a distance of 6.97 feet to the POINT OF BEGINNING.

CONTAINING: 1072 square feet or 0.024 acres, more or less.

SURVEYOR'S REPORT

1. BASIS OF BEARINGS: Bearings are based on the North Right of Way line of Riverside Drive as shown on the Specific Purpose Survey, SFN1525, prepared by Sue Scholpp, dated 10/20/2010, revised 1/10/2012, being N84°55'16"W.
2. Deed information shown hereon is in reference to the Warranty Deed recorded in Official Records Book 6523, Page 2374 of the public records of Pinellas County, Florida.
3. Plat information shown hereon is in reference to E.M. SMITHS BAYOU SUBDIVISION REVISED, recorded in Plat Book 21, Page 63 of the public records of Pinellas County.

Additions or deletions by other than the Professional Surveyor and Mapper in responsible charge are prohibited. Sketch and/or Description is invalid without the original signature and seal of the Professional Surveyor and Mapper

CALCULATED BY: RAC	The above Sketch and Land description was prepared under my supervision and is true and correct to the best of my knowledge and belief.
CHECKED BY: PS	By: Pinellas County Survey and Mapping Division
S.F.N.: 1673	DATE <u>5/4/2022</u> PENNY STANDRIDGE SIMONE, LAND SURVEYOR CERTIFICATE NUMBER: 5240 STATE OF FLORIDA, PHONE # (327) 464-8904

SEAL

PINELLAS COUNTY
 PUBLIC WORKS
 SURVEY AND MAPPING DIVISION
 22211 U.S. HIGHWAY 19 N.
 CLEARWATER, FLORIDA 33765-2328



SECTION 11, TOWNSHIP 27 SOUTH, RANGE 15 EAST

SKETCH - NOT A SURVEY

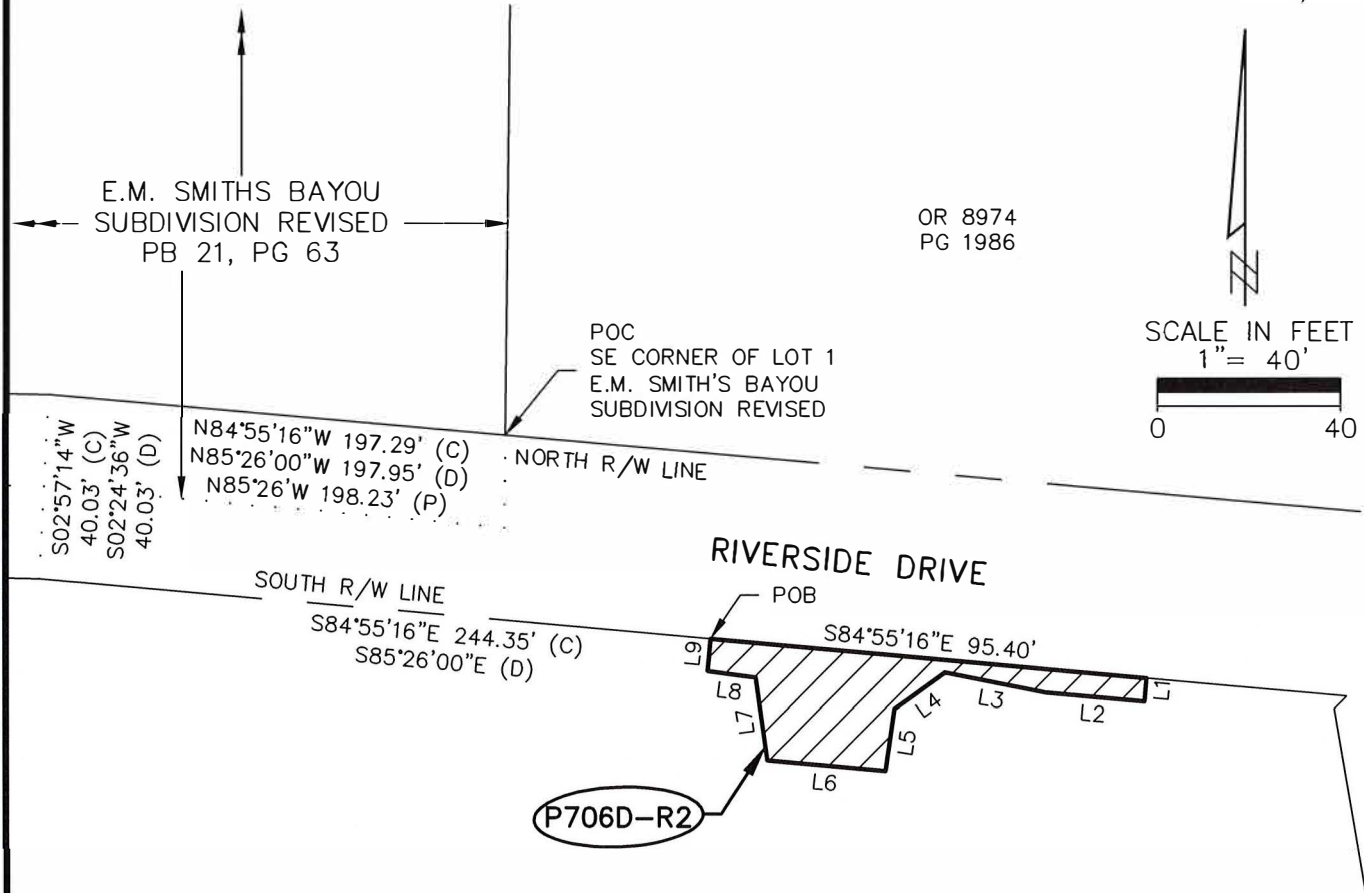

OR 6523
 PG 2374

LINE TABLE		
LINE #	BEARING	LENGTH
L1	S05°04'44"W	5.00'
L2	N84°55'17"W	21.87'
L3	N79°02'45"W	22.07'
L4	S54°31'43"W	13.46'
L5	S08°15'32"W	13.53'
L6	N84°55'16"W	25.93'
L7	N08°10'29"W	18.04'
L8	N82°20'51"W	10.54'
L9	N05°04'44"E	6.97'

LEGEND	
(C)	CALCULATED DATA
(D)	DEED DATA
OR	OFFICIAL RECORDS BOOK
(P)	PLAT DATA
PB	PLAT BOOK
PG	PAGE
POB	POINT OF BEGINNING
POC	POINT OF COMMENCEMENT
R/W	RIGHT OF WAY

CALCULATED BY:	RAC
CHECKED BY:	PS
S.F.N.:	1673

PINELLAS COUNTY
 PUBLIC WORKS
 SURVEY AND MAPPING DIVISION
 22211 U.S. HIGHWAY 19 N.
 CLEARWATER, FLORIDA 33765-2328



SECTION 11, TOWNSHIP 27 SOUTH, RANGE 15 EAST

DESCRIPTION

A portion of that certain parcel, as described in Official Records Book 6523, Page 2374, public records of Pinellas County, Florida, in Section 11, Township 27 South, Range 15 East, Pinellas County, Florida, being described as follows:

Commencing at the Southeast corner of Lot 1, E.M. SMITHS BAYOU SUBDIVISION REVISED, recorded in Plat Book 21, Page 63, public records of Pinellas County, Florida; thence N84°55'16"W, for a distance of 197.29 feet (N89°26'00"W 197.95 feet per Deed; N85°26'W, 198.23 feet per Plat) along the North Right-of-Way line of Riverside Drive; thence S02°57'14"W, for a distance of 40.03 feet (S02°24'36"W, 40.03 feet per Deed) to a point on the North line of the aforementioned parcel described in Official Records Book 6523, Page 2374, the same being the South Right-of-Way line of Riverside Drive; thence along said North line S84°55'16"E (S85°26'00"E per Deed), for a distance of 210.21 feet to the POINT OF BEGINNING; thence continue along said North line S84°55'16"E, for a distance of 10.00 feet; thence S05°04'44"W, for a distance of 6.43 feet; thence N84°55'16"W, for a distance of 10.00 feet; thence N05°04'44"E, for a distance of 6.43 feet to the POINT OF BEGINNING.

CONTAINING: 64 square feet or 0.001 acres, more or less.

SURVEYOR'S REPORT

1. BASIS OF BEARINGS: Bearings are based on the North Right of Way line of Riverside Drive as shown on the Specific Purpose Survey, SFN1525, prepared by Sue Scholpp, dated 10/20/2010, revised 1/10/2012, being N84°55'16"W.
2. Deed information shown hereon is in reference to the Warranty Deed recorded in Official Records Book 6523, Page 2374 of the public records of Pinellas County, Florida.
3. Plat information shown hereon is in reference to E.M. SMITHS BAYOU SUBDIVISION REVISED, recorded in Plat Book 21, Page 63 of the public records of Pinellas County.

Additions or deletions by other than the Professional Surveyor and Mapper in responsible charge are prohibited. Sketch and/or Description is invalid without the original signature and seal of the Professional Surveyor and Mapper

CALCULATED BY: RAC	The above Sketch and Land description was prepared under my supervision and is true and correct to the best of my knowledge and belief.
CHECKED BY: PS	By: Pinellas County Survey and Mapping Division
S.F.N.: 1673	DATE <u>5/4/2022</u> PENNY STANDRIDGE SIMONE, LAND SURVEYOR CERTIFICATE NUMBER: 5240 STATE OF FLORIDA, PHONE # (727) 464-8904

STATE OF FLORIDA SEAL

EXHIBIT E__

Parcel No.: P706E
 SHEET 1 OF 2

PINELLAS COUNTY
 PUBLIC WORKS
 SURVEY AND MAPPING DIVISION
 22211 U.S. HIGHWAY 19 N.
 CLEARWATER, FLORIDA 33765-2328



SECTION 11, TOWNSHIP 27 SOUTH, RANGE 15 EAST

SKETCH - NOT A SURVEY

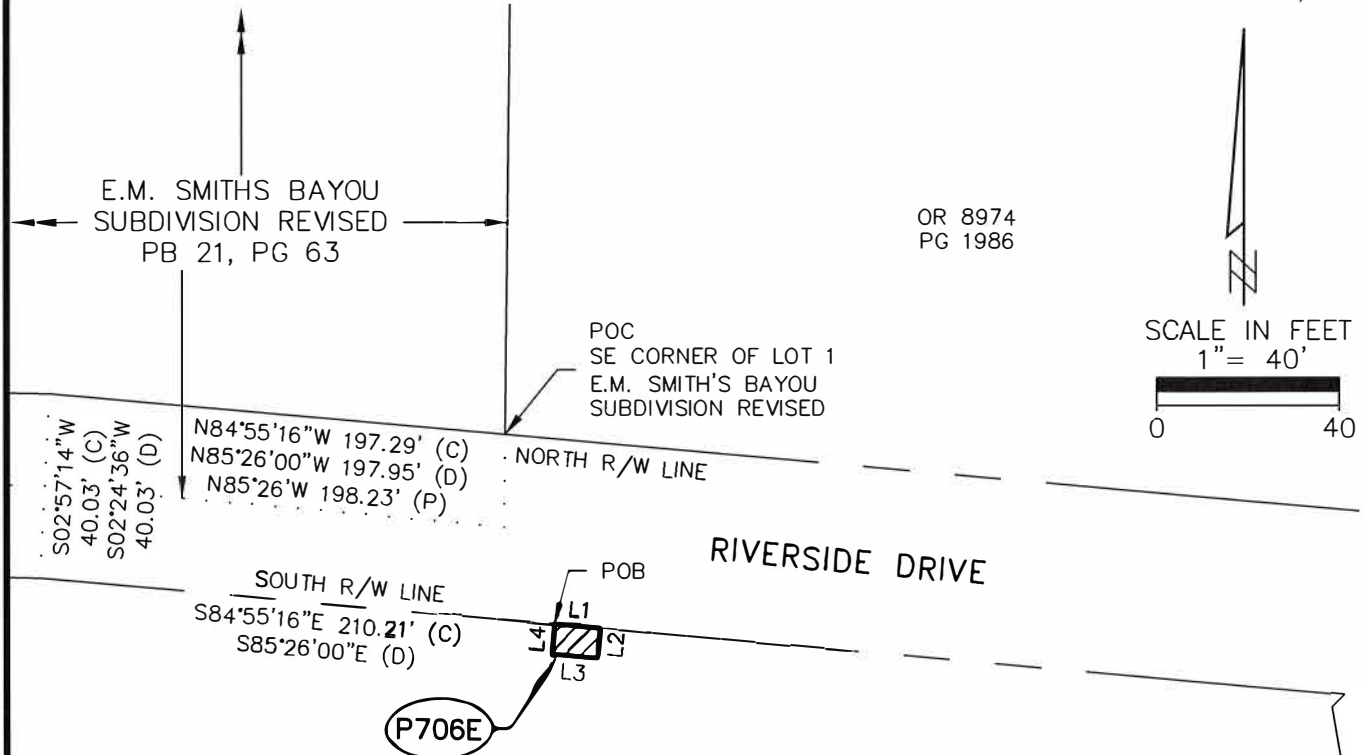

OR 6523
 PG 2374

LINE TABLE		
LINE #	BEARING	LENGTH
L1	S84°55'16"E	10.00'
L2	S05°04'44"W	6.43'
L3	N84°55'16"W	10.00'
L4	N05°04'44"E	6.43'

LEGEND	
(C)	CALCULATED DATA
(D)	DEED DATA
OR	OFFICIAL RECORDS BOOK
(P)	PLAT DATA
PB	PLAT BOOK
PG	PAGE
POB	POINT OF BEGINNING
POC	POINT OF COMMENCEMENT
R/W	RIGHT OF WAY

CALCULATED BY:	RAC
CHECKED BY:	PS
S.F.N.:	1673



SECTION 11, TOWNSHIP 27 SOUTH, RANGE 15 EAST

DESCRIPTION

A portion of that certain parcel, as described in Official Records Book 6523, Page 2374, public records of Pinellas County, Florida, in Section 11, Township 27 South, Range 15 East, Pinellas County, Florida, being described as follows:

Commencing at the Southeast corner of Lot 1, E.M. SMITHS BAYOU SUBDIVISION REVISED, recorded in Plat Book 21, Page 63, public records of Pinellas County, Florida; thence N84°55'16"W, for a distance of 197.29 feet (N89°26'00"W 197.95 feet per Deed; N85°26'W, 198.23 feet per Plat) along the North Right-of-Way line of Riverside Drive; thence S02°57'14"W, for a distance of 40.03 feet (S02°24'36"W, 40.03 feet per Deed) to a point on the North line of the aforementioned parcel described in Official Records Book 6523, Page 2374, the same being the South Right-of-Way line of Riverside Drive; thence along said North line S84°55'16"E (S85°26'00"E per Deed), for a distance of 348.75 feet to the POINT OF BEGINNING; thence continue along said North line S84°55'16"E, for a distance of 34.83 feet to a point on the mean high water line of Tarpon Bayou as defined by the existing concrete seawall; thence along said mean high water line the following two (2) courses; (1) S44°11'21"W, for a distance of 3.80 feet; (2) S09°43'14"E, for a distance of 2.12 feet; thence leaving said mean high water line, N84°55'17"W, for a distance of 19.56 feet; thence N08°20'41"W, for a distance of 4.37 feet; thence N83°58'33"W, for a distance of 3.63 feet; thence S09°48'10"W, for a distance of 4.32 feet; thence N84°56'03"W, for a distance of 8.41 feet; thence N05°04'44"E, for a distance of 5.00 feet to the POINT OF BEGINNING.

CONTAINING: 148 square feet or 0.003 acres, more or less.

SURVEYOR'S REPORT

1. BASIS OF BEARINGS: Bearings are based on the North Right of Way line of Riverside Drive as shown on the Specific Purpose Survey, SFN1525, prepared by Sue Scholpp, dated 10/20/2010, revised 1/10/2012, being N84°55'16"W.
2. Deed information shown hereon is in reference to the Warranty Deed recorded in Official Records Book 6523, Page 2374 of the public records of Pinellas County, Florida.
3. Plat information shown hereon is in reference to E.M. SMITHS BAYOU SUBDIVISION REVISED, recorded in Plat Book 21, Page 63 of the public records of Pinellas County.

Additions or deletions by other than the Professional Surveyor and Mapper in responsible charge are prohibited. Sketch and/or Description is invalid without the original signature and seal of the Professional Surveyor and Mapper

CALCULATED BY: RAC	The above Sketch and Land description was prepared under my supervision and is true and correct to the best of my knowledge and belief.
CHECKED BY: PS	By: <u>[Signature]</u> Pinellas County Survey and Mapping Division
S.F.N.: 1673	DATE <u>5/4/2022</u> PENNY STANDRIDGE SIMONE, LAND SURVEYOR CERTIFICATE NUMBER: 5240 STATE OF FLORIDA, PHONE # (727) 464-8904

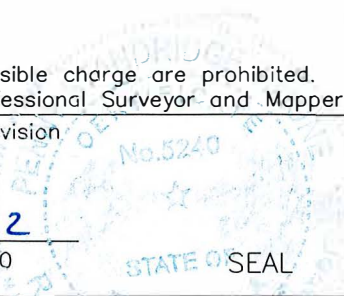

PINELLAS COUNTY
 PUBLIC WORKS
 SURVEY AND MAPPING DIVISION
 22211 U.S. HIGHWAY 19 N.
 CLEARWATER, FLORIDA 33765-2328



SECTION 11, TOWNSHIP 27 SOUTH, RANGE 15 EAST

SKETCH - NOT A SURVEY

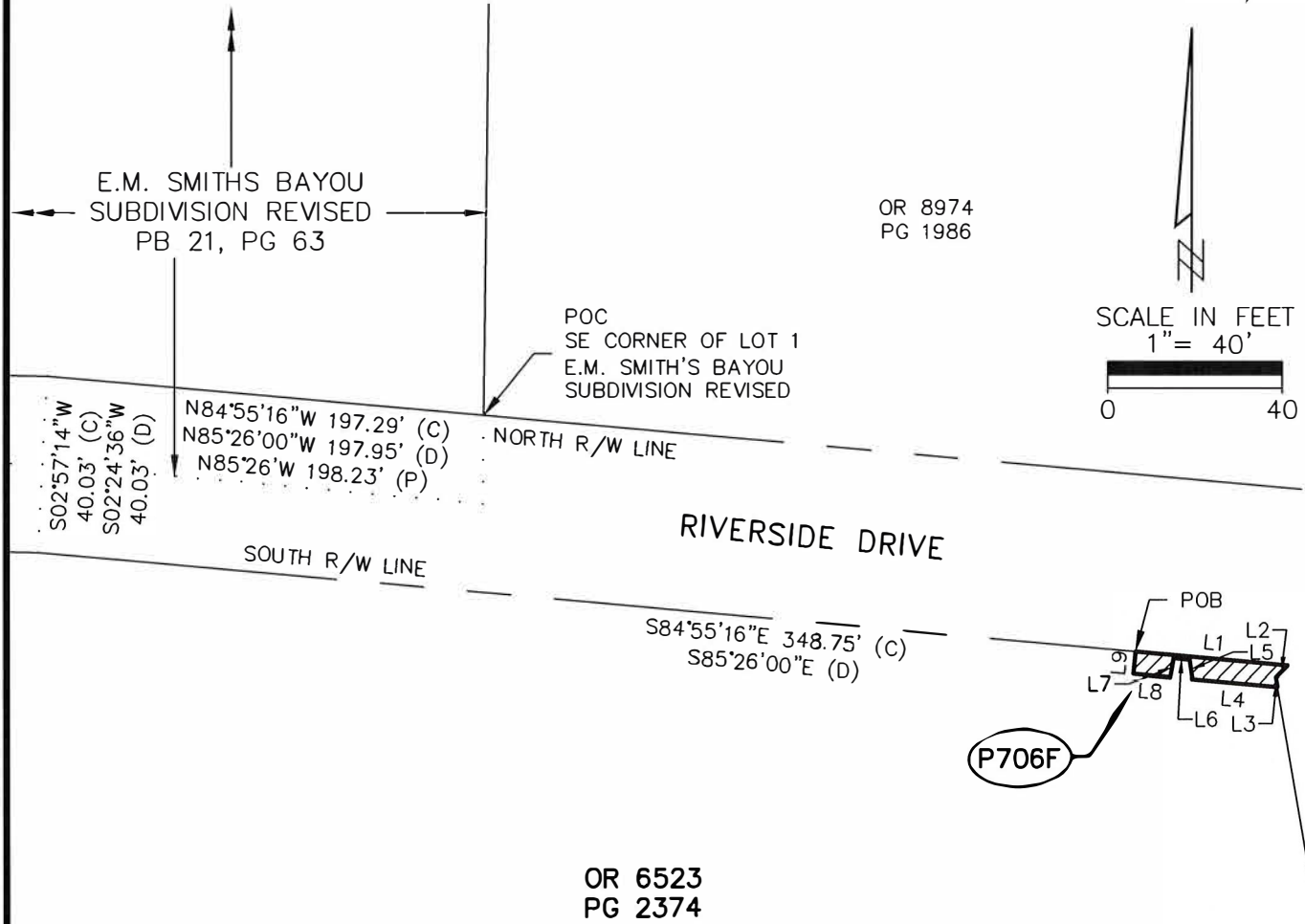

LINE TABLE		
LINE #	BEARING	LENGTH
L1	S84°55'16"E	34.83'
L2	S44°11'21"W	3.80'
L3	S09°43'14"E	2.12'
L4	N84°55'17"W	19.56'
L5	N08°20'41"W	4.37'
L6	N83°58'33"W	3.63'
L7	S09°48'10"W	4.32'
L8	N84°56'03"W	8.41'
L9	N05°04'44"E	5.00'

LEGEND	
(C)	CALCULATED DATA
(D)	DEED DATA
OR	OFFICIAL RECORDS BOOK
(P)	PLAT DATA
PB	PLAT BOOK
PG	PAGE
POB	POINT OF BEGINNING
POC	POINT OF COMMENCEMENT
R/W	RIGHT OF WAY

CALCULATED BY:	RAC
CHECKED BY:	PS
S.F.N.:	1673

PINELLAS COUNTY
 PUBLIC WORKS
 SURVEY AND MAPPING DIVISION
 22211 U.S. HIGHWAY 19 N.
 CLEARWATER, FLORIDA 33765-2328



SECTION 11, TOWNSHIP 27 SOUTH, RANGE 15 EAST

DESCRIPTION

A rectangular shaped tract, being a portion of that certain parcel, as described in Official Records Book 6523, Page 2374, public records of Pinellas County, Florida, in Section 11, Township 27 South, Range 15 East, Pinellas County, Florida, being described as follows:

Commencing at the Southeast corner of Lot 1, E.M. SMITHS BAYOU SUBDIVISION REVISED, recorded in Plat Book 21, Page 63, public records of Pinellas County, Florida; thence N84°55'16"W, for a distance of 197.29 feet (N89°26'00"W 197.95 feet per Deed; N85°26'W, 198.23 feet per Plat) along the North Right-of-Way line of Riverside Drive; thence S02°57'14"W, for a distance of 40.03 feet (S02°24'36"W, 40.03 feet per Deed) to a point on the North line of the aforementioned parcel described in Official Records Book 6523, Page 2374, the same being the South Right-of-Way line of Riverside Drive and the POINT OF BEGINNING; thence S00°49'44"W, for a distance of 3.89 feet; thence N89°14'17"W, for a distance of 6.02 feet; thence N00°49'44"E, for a distance of 3.89 feet returning to the aforementioned North line of said parcel recorded in Official Records Book 6523, Page 2374; thence S89°10'16"E (S89°41'00"E per Deed) along said North line, for a distance of 6.02 feet to the POINT OF BEGINNING.

CONTAINING: 23 square feet or 0.001 acres, more or less.

SURVEYOR'S REPORT

1. BASIS OF BEARINGS: Bearings are based on the North Right of Way line of Riverside Drive as shown on the Specific Purpose Survey, SFN1525, prepared by Sue Scholpp, dated 10/20/2010, revised 1/10/2012, being N84°55'16"W.
2. Deed information shown hereon is in reference to the Warranty Deed recorded in Official Records Book 6523, Page 2374 of the public records of Pinellas County, Florida.
3. Plat information shown hereon is in reference to E.M. SMITHS BAYOU SUBDIVISION REVISED, recorded in Plat Book 21, Page 63 of the public records of Pinellas County.

Additions or deletions by other than the Professional Surveyor and Mapper in responsible charge are prohibited. Sketch and/or Description is invalid without the original signature and seal of the Professional Surveyor and Mapper

CALCULATED BY: RAC	The above Sketch and Land description was prepared under my supervision and is true and correct to the best of my knowledge and belief.
CHECKED BY: PS	By: Pinellas County Survey and Mapping Division
S.F.N.: 1673	DATE <u>5/4/2022</u> PENNY STANDRIDGE SIMONE, LAND SURVEYOR CERTIFICATE NUMBER: 5240 STATE OF FLORIDA, PHONE # (727) 464-8904

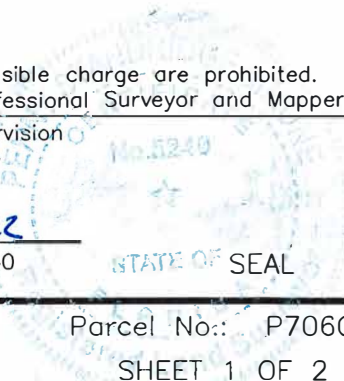

EXHIBIT G

Parcel No.: P706G
 SHEET 1 OF 2

PINELLAS COUNTY
 PUBLIC WORKS
 SURVEY AND MAPPING DIVISION
 22211 U.S. HIGHWAY 19 N.
 CLEARWATER, FLORIDA 33765-2328



SECTION 11, TOWNSHIP 27 SOUTH, RANGE 15 EAST
 SKETCH - NOT A SURVEY

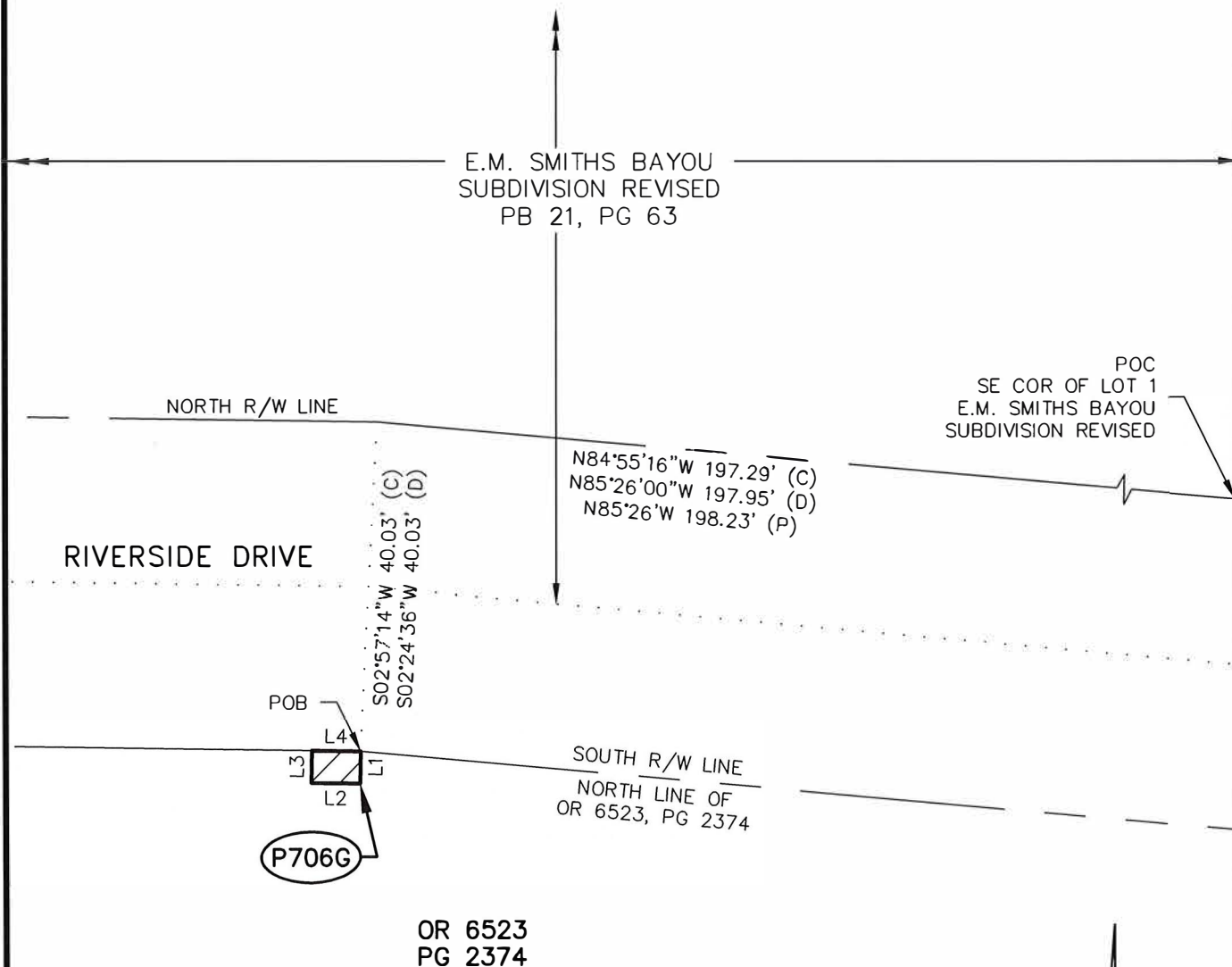

LINE TABLE		
LINE #	BEARING	LENGTH
L1	S00°49'44"W	3.89'
L2	N89°14'17"W	6.02'
L3	N00°49'44"E	3.89'
L4	S89°10'16"E	6.02'

LEGEND	
(C)	CALCULATED DATA
(D)	DEED DATA
OR	OFFICIAL RECORDS BOOK
(P)	PLAT DATA
PB	PLAT BOOK
PG	PAGE
POB	POINT OF BEGINNING
POC	POINT OF COMMENCEMENT
R/W	RIGHT OF WAY

CALCULATED BY:
 RAC
 CHECKED BY:
 PS
 S.F.N.:
 1673

