

DANSVILLE PHASE 6

A REPLAT OF A PORTION OF LOTS 3 & 4 OF PINELLAS GROVES, AS RECORDED IN PLAT BOOK 1, PAGE 55, OF THE PUBLIC RECORDS OF PINELLAS COUNTY, FLORIDA, LYING WITHIN THE NORTHEAST 1/4 OF SECTION 8, TOWNSHIP 30 SOUTH, RANGE 15 EAST, PINELLAS COUNTY, FLORIDA

LEGAL DESCRIPTION:

A PARCEL OF LAND BEING A PORTION OF LOT 3 AND LOT 4, ACCORDING TO THE PLAT OF PINELLAS GROVES, AS RECORDED IN PLAT BOOK 1, PAGE 55 OF THE PUBLIC RECORDS OF PINELLAS COUNTY, FLORIDA, LYING IN SECTION 8, TOWNSHIP 30 SOUTH, RANGE 15 EAST, PINELLAS COUNTY, FLORIDA, BEING MORE PARTICULARLY DESCRIBED AS FOLLOWS:

BEGIN AT THE NORTHEAST CORNER OF 132ND AVENUE NORTH, ACCORDING TO THE PLAT OF DANSVILLE - PHASE 2, AS RECORDED IN PLAT BOOK 134, PAGE 87 OF THE PUBLIC RECORDS OF PINELLAS COUNTY, FLORIDA; THENCE THE FOLLOWING SIX (6) COURSES ALONG THE NORTHERLY RIGHT-OF-WAY LINE OF 132ND AVENUE NORTH; (1) THENCE N89°43'52"W, (BEING THE BASIS OF BEARINGS FOR THIS LEGAL DESCRIPTION), FOR 30.86 FEET TO THE POINT OF INTERSECTION WITH A NON-TANGENT CURVE, CONCAVE SOUTHEASTERLY; (2) THENCE SOUTHWESTERLY ALONG THE ARC OF SAID CURVE, WITH A RADIAL BEARING OF S09°53'42"E, HAVING A RADIUS OF 117.34 FEET, A CENTRAL ANGLE OF 28°18'09", AN ARC LENGTH OF 57.96 FEET, AND A CHORD BEARING S65°57'13"W, FOR 57.37 FEET, TO THE POINT OF REVERSE CURVATURE OF A CURVE CONCAVE NORTHERLY; (3) THENCE WESTERLY ALONG THE ARC OF SAID CURVE, HAVING A RADIUS OF 66.97 FEET, A CENTRAL ANGLE OF 38°27'59", AN ARC LENGTH OF 44.96 FEET, AND A CHORD BEARING S71°02'08"W, FOR 44.12 FEET; (4) THENCE N89°43'52"W, FOR 124.29 FEET; (5) THENCE N87°42'15"W, FOR 57.14 FEET TO THE POINT OF CURVATURE OF A CURVE CONCAVE SOUTHERLY; (6) THENCE WESTERLY ALONG THE ARC OF SAID CURVE, HAVING A RADIUS OF 2,223.50 FEET, A CENTRAL ANGLE OF 3°45'30", AN ARC LENGTH OF 145.85 FEET, AND A CHORD BEARING N89°35'00"W, FOR 145.82 FEET TO THE POINT OF INTERSECTION WITH A NON-TANGENT LINE; THENCE LEAVING SAID NORTHERLY RIGHT-OF-WAY LINE OF 132ND AVENUE NORTH, N00°13'12"E, FOR 101.03 FEET; THENCE S89°43'52"E, FOR 17.27 FEET; THENCE N00°12'07"E, FOR 1.57 FEET; THENCE S89°43'52"E, FOR 102.45 FEET TO THE POINT OF INTERSECTION WITH THE EASTERLY LINE OF LOT 4, SAME BEING THE WESTERLY LINE OF LOT 3, ACCORDING TO THE PLAT OF PINELLAS GROVES, AS RECORDED IN PLAT BOOK 1, PAGE 55 OF THE PUBLIC RECORDS OF PINELLAS COUNTY, FLORIDA; THENCE S00°12'07"W, ALONG SAID EASTERLY LINE OF LOT 4, SAME BEING SAID WESTERLY LINE OF LOT 3, FOR 5.00 FEET; THENCE LEAVING SAID EASTERLY LINE OF LOT 4, SAME BEING SAID WESTERLY LINE OF LOT 3, S89°43'52"E, FOR 132.30 FEET; THENCE N00°11'02"E, FOR 349.30 FEET; THENCE S89°50'28"E, FOR 200.00 FEET TO THE POINT OF INTERSECTION WITH THE EASTERLY LINE OF SAID LOT 3; THENCE S00°11'02"W, ALONG SAID EASTERLY LINE OF LOT 3, FOR 149.68 FEET TO THE POINT OF INTERSECTION WITH THE NORTHERLY RIGHT-OF-WAY EASEMENT LINE, AS DESCRIBED IN OFFICIAL RECORDS BOOK 10825, PAGE 722 AND OFFICIAL RECORDS BOOK 10831, PAGE 1388 OF THE PUBLIC RECORDS OF PINELLAS COUNTY, FLORIDA; THENCE N89°43'52"W, ALONG SAID NORTHERLY RIGHT-OF-WAY EASEMENT LINE AS DESCRIBED IN OFFICIAL RECORDS BOOK 10825, PAGE 722 AND OFFICIAL RECORDS BOOK 10831, PAGE 1388, S00°11'02"W, FOR 100.00 FEET; THENCE S89°43'52"E, FOR 100.00 FEET TO THE POINT OF INTERSECTION WITH SAID EASTERLY LINE OF LOT 3; THENCE S00°11'02"W, ALONG SAID EASTERLY LINE OF LOT 3, FOR 161.84 FEET TO THE POINT OF BEGINNING.

CONTAINING 102,294 SQUARE FEET OR 2.348 ACRES, MORE OR LESS.

DEDICATION:

THE UNDERSIGNED HEREBY CERTIFIES THAT PINELLAS COUNTY, A POLITICAL SUBDIVISION OF THE STATE OF FLORIDA, ARE THE OWNERS OF THE HEREIN DESCRIBED TRACT OF LAND PLATTED AS DANSVILLE PHASE 6 AND BESIDES ITS INTERESTS THEREIN, THERE ARE NO OUTSTANDING INTERESTS IN SAID TRACT OF LAND AND THAT THE OWNER DOES HEREBY DEDICATE TO THE PUBLIC, ALL RIGHTS-OF-WAY AND EASEMENTS DESIGNATED ON THE PLAT AS "PUBLIC", AND FURTHER MAKES THE FOLLOWING CONVEYANCES, DEDICATIONS AND RESERVATIONS:

OWNER DOES FURTHER DEDICATE TO THE PUBLIC AND ALL APPROPRIATE UTILITY ENTITIES A NON-EXCLUSIVE EASEMENT FOR STREET LIGHTS, TELEPHONE, ELECTRIC, CABLE TELEVISION, AND OTHER PUBLIC UTILITIES OVER AND ACROSS THOSE PORTIONS OF THE PLAT SHOWN AS PUBLIC UTILITY EASEMENTS, THE USE AND BENEFIT OF WHICH SHALL EXTEND AND INSURE TO THE BENEFIT OF ALL LOCAL, STATE AND FEDERAL GOVERNMENTS, INCLUDING ALL AGENCIES AND DEPARTMENTS THEREOF.

OWNER:

PINELLAS COUNTY, A POLITICAL SUBDIVISION OF THE STATE OF FLORIDA

THIS DEDICATION TO BE EXECUTED IN ITS NAME BY ITS BOARD OF COUNTY COMMISSIONERS ACTING BY THE CHAIR OF SAID BOARD, THIS

16th DAY OF January, 2024



ATTEST: [Signature]
DEPUTY CLERK
PINELLAS COUNTY, FLORIDA

BY ITS BOARD OF COUNTY COMMISSIONERS

[Signature]

Kathleen Peters, ITS CHAIR

CERTIFICATE OF APPROVAL OF COUNTY COMMISSION:

STATE OF FLORIDA
COUNTY OF PINELLAS

IT IS HEREBY CERTIFIED THAT THIS PLAT HAS BEEN OFFICIALLY APPROVED FOR RECORD BY THE BOARD OF COUNTY COMMISSIONERS OF THE COUNTY OF PINELLAS, FLORIDA, THIS 16th DAY OF January, 2024.

APPROVED: [Signature]
CHAIRMAN, BOARD OF COUNTY COMMISSIONERS

KEN BURKE, CLERK
PINELLAS COUNTY, FLORIDA

BY: [Signature]
DEPUTY CLERK

CERTIFICATE OF APPROVAL OF COUNTY CLERK:

STATE OF FLORIDA
COUNTY OF PINELLAS

I, KEN BURKE, CLERK OF THE CIRCUIT COURT OF PINELLAS COUNTY, FLORIDA, HEREBY CERTIFY THAT THIS PLAT HAS BEEN EXAMINED AND THAT IT COMPLIES IN FORM WITH ALL THE REQUIREMENTS OF THE STATUTES OF THE STATE OF FLORIDA PERTAINING TO MAPS AND PLATS, AND THAT THIS PLAT HAS BEEN FILED FOR RECORD IN PLAT BOOK 147 PAGES 7-8, OF THE PUBLIC RECORDS OF PINELLAS COUNTY, FLORIDA, THIS 19 DAY OF January, 2024.

KEN BURKE, CLERK
PINELLAS COUNTY, FLORIDA

BY: [Signature]
DEPUTY CLERK

CERTIFICATE OF CONFORMITY:

I HEREBY CERTIFY THAT PURSUANT TO CHAPTER 177.081(1), FLORIDA STATUTES, I HAVE REVIEWED THIS PLAT AND FIND THAT IT CONFORMS TO CHAPTER 177, PART 1, OF THE FLORIDA STATUTES.

[Signature]
GEORGE A. SHIMP III
PROFESSIONAL SURVEYOR & MAPPER NO. 6137
PINELLAS COUNTY SURVEY AND MAPPING DIVISION
DEPARTMENT OF PUBLIC WORKS
22211 U.S. HIGHWAY 19 NORTH
CLEARWATER, FLORIDA 33765

12/5/2023
DATE

SURVEYOR'S CERTIFICATE:

I, THE UNDERSIGNED SURVEYOR, HEREBY CERTIFY THAT THIS PROPERTY WAS SURVEYED AND THIS PLATTED SUBDIVISION IS A CORRECT REPRESENTATION OF THE LAND BEING SUBDIVIDED; THAT THIS PLAT WAS PREPARED UNDER MY RESPONSIBLE DIRECTION AND SUPERVISION; THAT THIS PLAT COMPLIES WITH ALL OF THE SURVEY REQUIREMENTS OF CHAPTER 177, PART 1, FLORIDA STATUTES; AND THAT THE PERMANENT REFERENCE MONUMENTS (PRM'S), PERMANENT CONTROL POINTS (PCP'S) AND LOT CORNERS, AS SHOWN HEREON, HAVE BEEN SET AS OF THE DATE OF THIS CERTIFICATION.

SIGNED AND SEALED THIS 16th DAY OF DECEMBER, 2023.

JARED J. PATENAUDE
PROFESSIONAL SURVEYOR AND MAPPER
LICENSE NUMBER LS 6971

FLORIDA DESIGN CONSULTANTS, INC.
CERTIFICATE OF AUTHORIZATION, LB 6707
20525 AMBERFIELD DRIVE, SUITE 201
LAND O' LAKES, FLORIDA

NOTES:

- BEARINGS SHOWN HEREON ARE BASED UPON THE NORTHERLY RIGHT-OF-WAY LINE OF 132ND AVENUE NORTH, ACCORDING TO THE PLAT OF "DANSVILLE - PHASE 2", AS RECORDED IN PLAT BOOK 134, PAGE 87, OF THE PUBLIC RECORDS OF PINELLAS COUNTY, FLORIDA, BEING N89°43'52"W, AS SHOWN HEREON.
- ALL SIDE LOT LINES LABELED (NR) ARE NON-RADIAL TO THE CURVED LOT LINE, ALL OTHER LINES INTERSECTING CURVED LOT LINES ARE CONSIDERED RADIAL UNLESS NOTED (NR).
- ALL PLATTED UTILITY EASEMENTS SHALL PROVIDE THAT SUCH EASEMENTS SHALL ALSO BE EASEMENTS FOR THE CONSTRUCTION, INSTALLATION, MAINTENANCE, AND OPERATION OF CABLE TELEVISION SERVICES; PROVIDED, HOWEVER NO SUCH CONSTRUCTION, INSTALLATION, MAINTENANCE, AND OPERATION OF CABLE TELEVISION SERVICES SHALL INTERFERE WITH THE FACILITIES AND SERVICES OF AN ELECTRIC, TELEPHONE, GAS, OR OTHER PUBLIC UTILITY. IN THE EVENT A CABLE TELEVISION COMPANY DAMAGES THE FACILITIES OF A PUBLIC UTILITY, IT SHALL BE SOLELY RESPONSIBLE FOR THE DAMAGES. THIS SECTION SHALL NOT APPLY TO THOSE PRIVATE EASEMENTS GRANTED TO OR OBTAINED BY A PARTICULAR ELECTRIC, TELEPHONE, GAS, OR OTHER PUBLIC UTILITY. SUCH CONSTRUCTION, INSTALLATION, MAINTENANCE, AND OPERATION SHALL COMPLY WITH THE NATIONAL ELECTRICAL SAFETY CODE AS ADOPTED BY THE FLORIDA PUBLIC SERVICE COMMISSION.
- PERMANENT CONTROL POINTS SET BY FLORIDA DESIGN CONSULTANTS, INC. WILL BE A SET NAIL WITH DISC STAMPED "PCP LB 6707". LOT CORNERS SET BY FLORIDA DESIGN CONSULTANTS, INC. WILL BE SET 5/8" IRON ROD WITH CAP STAMPED "FDC LB 6707" (IN SOFT SURFACES) OR A SET NAIL WITH DISC STAMPED "FDC LB 6707" (IN HARD SURFACES). MONUMENTS WERE FOUND OR SET AT EACH LOT CORNER, POINT OF INTERSECTION AND CHANGES OF DIRECTION OF LINES WITHIN THE SUBDIVISION AS REQUIRED BY CHAPTER 177 OF THE FLORIDA STATUTES. WHERE CORNERS COULD NOT BE SET, WITNESS CORNERS WERE FOUND OR SET AS NOTED.
- A PORTION OF LOTS 2 THROUGH 7 IS SUBJECT TO THE DECLARATION OF RESTRICTIVE COVENANT AS RECORDED IN OFFICIAL RECORDS BOOK 18924, PAGE 1499, OF THE PUBLIC RECORDS OF PINELLAS COUNTY, FLORIDA, UNTIL SUCH TIME THAT IT IS RELEASED.

 **FLORIDA DESIGN CONSULTANTS, INC.**
— THINK IT. ACHIEVE IT. —

20525 AMBERFIELD DRIVE, SUITE 201, LAND O LAKES, FLORIDA 34638
PHONE: (800) 532-1047 FAX: (727) 848-3648 WWW.FLDESIGN.COM L.B. NO. 6707
AUGUST 2020 - 0129-0069 (932)

NOTICE: THIS PLAT, AS RECORDED IN ITS GRAPHIC FORM, IS THE OFFICIAL DEPICTION OF THE SUBDIVIDED LANDS DESCRIBED HEREIN AND WILL IN NO CIRCUMSTANCES BE SUPPLANTED IN AUTHORITY BY ANY OTHER GRAPHIC OR DIGITAL FORM OF THE PLAT. THERE MAY BE ADDITIONAL RESTRICTIONS THAT ARE NOT RECORDED ON THIS PLAT THAT MAY BE FOUND IN THE PUBLIC RECORDS OF THIS COUNTY.

DANSVILLE PHASE 6

A REPLAT OF A PORTION OF LOTS 3 & 4 OF PINELLAS GROVES, AS RECORDED IN PLAT BOOK 1, PAGE 55, OF THE PUBLIC RECORDS OF PINELLAS COUNTY, FLORIDA, LYING WITHIN THE NORTHEAST 1/4 OF SECTION 8, TOWNSHIP 30 SOUTH, RANGE 15 EAST, PINELLAS COUNTY, FLORIDA

LEGEND:

- COR = CORNER
- DE = DRAINAGE EASEMENT
- E'LY = EASTERLY
- ESMT = EASEMENT
- FDC = FLORIDA DESIGN CONSULTANTS
- FN&D = FOUND NAIL & DISK "LB 6707" (UNLESS OTHERWISE NOTED)
- LB = LICENSED BUSINESS
- N/F = NOT FOUND
- (NR) = NON-RADIAL
- N'LY = NORTHERLY
- N.T. = NON-TANGENT
- O/A = OVERALL
- ORB = OFFICIAL RECORDS BOOK
- PB = PLAT BOOK
- PCP = PERMANENT CONTROL POINT (OR P.C.P.)
- PG(S) = PAGE(S)
- POB = POINT OF BEGINNING
- PRM = PERMANENT REFERENCE MONUMENT
- R/W = RIGHT-OF-WAY
- SCM(W) = SET 4"x4" CONCRETE MONUMENT "FDC LB 6707 WIT COR"
- SEC = SECTION
- SN&D = SET MAG NAIL AND DISK "LB 6707" (UNLESS OTHERWISE NOTED)
- UE = UTILITY EASEMENT
- W'LY = WESTERLY

- = FOUND 4"x4" CONCRETE MONUMENT "PRM LB6707"
- = PERMANENT CONTROL POINT (PCP) (SEE NOTES #4)
- = SET 5/8" CAPPED IRON ROD LB6707 OR SET NAIL AND DISK LB6707 (SEE NOTES #4)
- = SET 4"x4" CONCRETE MONUMENT "PRM LB6707" (UNLESS OTHERWISE NOTED)

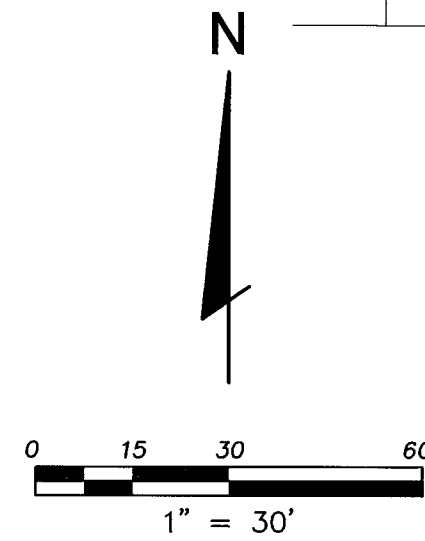

| LINE TABLE | | |
|------------|-------------|--------|
| LINE | BEARING | LENGTH |
| L1 | N87°42'15"W | 57.14' |
| L2 | S89°43'52"E | 17.27' |
| L3 | N00°12'07"E | 1.57' |
| L4 | S00°12'07"W | 5.00' |
| L5 | N89°43'52"W | 25.24' |
| L6 | N87°52'01"W | 15.39' |
| L7 | S89°50'28"E | 10.00' |
| L8 | S45°13'32"W | 21.20' |
| L9 | S89°43'52"E | 10.24' |
| L10 | N69°29'12"W | 46.92' |

| CURVE TABLE | | | | | | |
|-------------|----------|---------|---------|-------------|------------|----------------|
| CURVE | RADIUS | LENGTH | CHORD | BEARING | DELTA | RADIAL BEARING |
| C1 | 117.34' | 57.96' | 57.37' | S65°57'13"W | 028°18'09" | S09°53'42"E |
| C2 | 66.97' | 44.96' | 44.12' | S71°02'08"W | 038°27'59" | - |
| C3 | 2223.50' | 145.85' | 145.82' | N89°35'00"W | 003°45'30" | - |
| C4 | 117.34' | 53.95' | 53.48' | S66°55'57"W | 026°20'41" | - |
| C5 | 117.34' | 4.01' | 4.01' | S52°46'53"W | 001°57'28" | - |
| C6 | 2223.50' | 19.75' | 19.75' | N87°57'31"W | 000°30'32" | - |
| C7 | 2223.50' | 63.01' | 63.01' | N89°01'30"W | 001°37'25" | - |
| C8 | 2223.50' | 63.09' | 63.09' | S89°21'02"W | 001°37'33" | - |
| C9 | 56.00' | 276.22' | 70.01' | S00°17'41"E | 282°36'59" | - |
| C10 | 56.00' | 138.58' | 105.83' | S70°42'34"E | 141°47'12" | - |
| C11 | 56.00' | 137.64' | 105.52' | S70°35'55"W | 140°49'47" | - |
| C12 | 10.00' | 8.85' | 8.57' | S64°21'32"E | 050°44'41" | - |
| C13 | 25.00' | 39.31' | 35.38' | N45°13'35"E | 090°05'06" | - |
| C14 | 66.00' | 91.91' | 84.66' | N88°16'11"E | 079°47'32" | - |
| C15 | 10.00' | 7.85' | 7.65' | S67°14'15"E | 044°59'15" | - |
| C16 | 10.00' | 1.00' | 1.00' | S41°51'54"E | 005°45'26" | - |

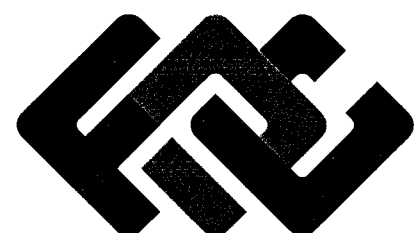
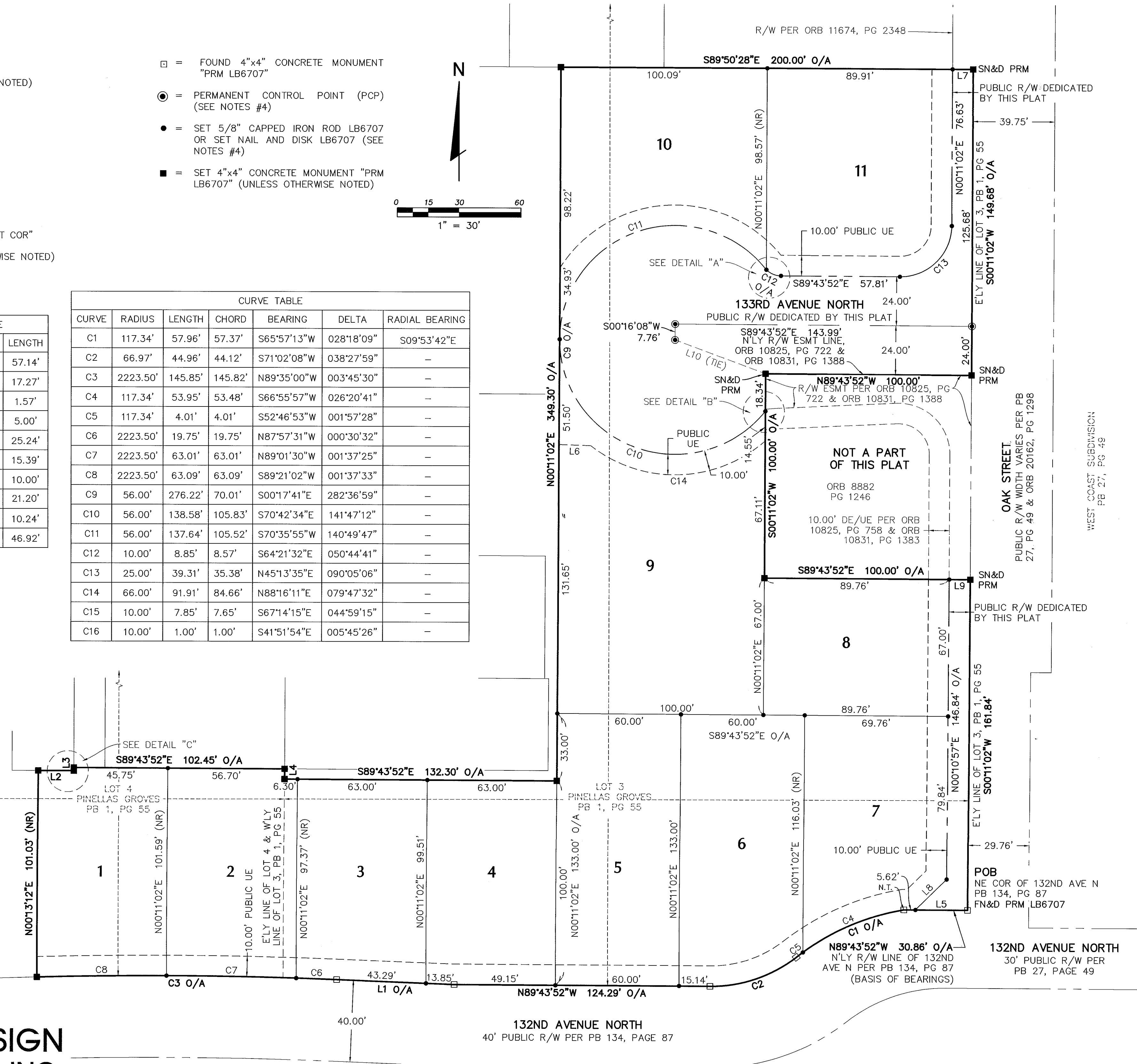
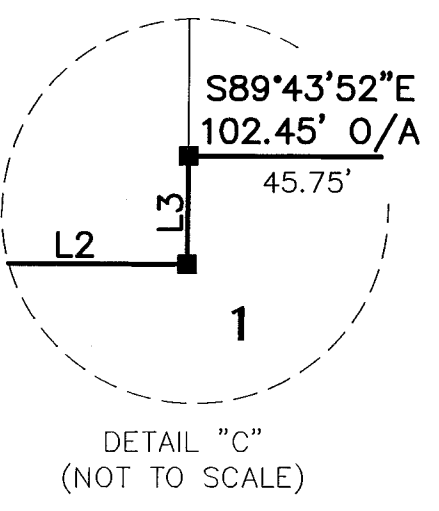
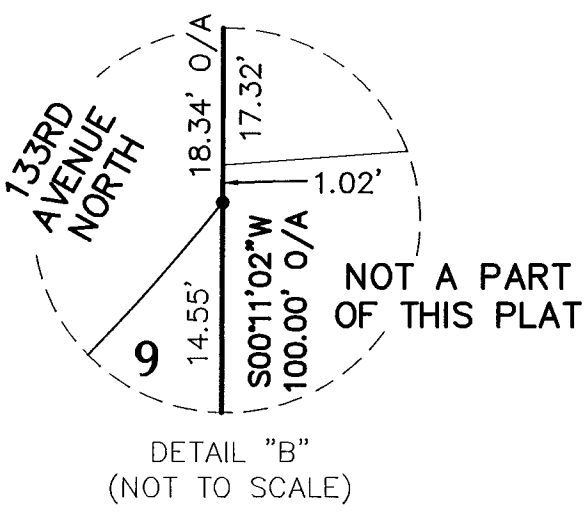
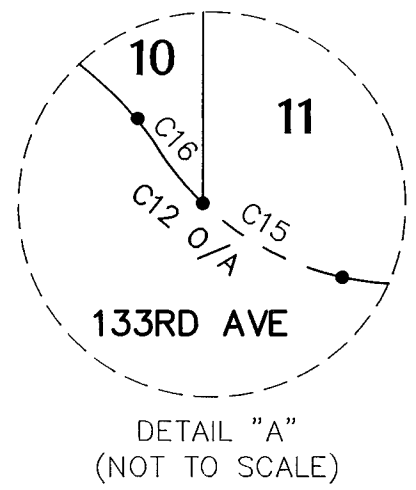

FLORIDA DESIGN CONSULTANTS, INC.
— THINK IT. ACHIEVE IT. —

20525 AMBERFIELD DRIVE, SUITE 201, LAND O LAKES, FLORIDA 34638
PHONE: (800) 532-1047 FAX: (727) 848-3648 WWW.FLDESIGN.COM L.B. NO. 6707

DANSVILLE - PHASE 2
PB 134, PG 87